

FCC STATEMENT

This device complies with Part 15 of the FCC Rules. Operation is subject to the following two conditions:

- (1) This device may not cause harmful interference, and
- (2) This device must accept any interference received, including interference that may cause undesired operation.

Note:

This equipment has been tested and found to comply with the limits for Class B digital devices, pursuant to Part 15 of the FCC rules. These limits are designed to provide reasonable protection against harmful interference in a residential installation. This equipment generates uses and can radiate radio frequency energy and, if not installed and used in accordance with the instructions, may cause harmful interference to radio communications. However, there is no guarantee that interference will not occur in a particular installation. If this equipment does cause harmful interference to radio or television reception, which can be determined by turning the equipment off and on, the user is encouraged to try to correct the interference by one or more of the following measures:

- Reorient or relocate the receiving antenna.
- Increase the separation between the equipment and receiver.
- Connect the equipment into an outlet on a circuit different from that to which the receiver is connected.
- Consult the dealer or an experienced radio/TV technician for help.

Use of shielded cable is required to comply with Class B limits in Subpart B of Part 15 of the FCC rules.

Do not make any changes or modifications to the equipment unless otherwise specified in the manual. If such changes or modifications should be made, you could be required to stop operation of the equipment.

Notice

If static electricity or electromagnetism causes data transfer to discontinue midway (fail), restart the application or disconnect and connect the communication cable (USB, etc.) again.



©2008 by  Polaroid All rights reserved.

"Polaroid", "Polaroid and Pixel", and "Polaroid PoGo" are trademarks of Polaroid Corporation. The ZINK™ Technology and ZINK™ trademarks are owned by ZINK Imaging, Inc. Used under license.

Changes are periodically made to this document. Changes, technical inaccuracies, and typographic errors will be corrected in subsequent editions.

For service, support and warranty information, visit www.polaroid.com.



This product contains electrical or electronic materials. The presence of these materials may, if not disposed of properly, have potential adverse effects on the environment and human health. Presence of this label on the product means it should not be disposed of as unsorted waste and must be collected separately. As a consumer, you are responsible for ensuring that this product is disposed of properly. To find out how to properly dispose of this product, please go to www.polaroid.com and click on Company or call the customer service number for your country listed in the instruction manual.

READ THIS FIRST

Trademark Information

- Microsoft® and Windows® are U.S. registered trademarks of Microsoft Corporation.
- Pentium® is a registered trademark of Intel Corporation.
- Macintosh is a trademark of Apple Inc.
- SD™ is a trademark.
- Other names and products may be trademarks or registered trademarks of their respective owners.

Product Information

- Product design and specifications are subject to change without notice. This includes primary product specifications, software, software drivers, and user's manual. This User Manual is a general reference guide for the product.
- The product and accessories that come with your camera may be different from those described in this manual. Retailers often specify slightly different product inclusions and accessories to suit their market requirements, customer demographics, and geographical preferences. Products very often vary between retailers especially with accessories such as batteries, chargers, AC adapters, memory cards, cables, pouches, and language support. Occasionally a retailer will specify a unique product color, appearance, and internal memory capacity. Contact your dealer for precise product definition and included accessories.
- The illustrations in this manual are for the purposes of explanation and may differ from your camera.
- The manufacturer assumes no liability for any errors or discrepancies in this user manual.

SAFETY INSTRUCTIONS

Please read all **Warnings** and **Cautions** before using this product.

Warnings

If foreign objects or water enter the camera, turn the power off and remove the battery.

Continued use may cause personal injury. Please consult our friendly customer service.



If the camera has been dropped or its case has been damaged, turn the power off and remove the battery.

Continued use may cause personal injury. Please consult our friendly customer service.



Do not disassemble, change or repair the camera.

Service should only be performed by a qualified technician. Please contact our friendly customer service should you have any questions.



Do not use the camera in areas near water.

Continued use may cause personal injury. Please consult our friendly customer service.



Do not place the camera on unstable surfaces.

This might cause the camera to fall and cause damage.



Keep the battery out of the reach of children.

Adult supervision is recommended when the product is being operated by young children.



Do not use the camera while you are walking, driving or riding a motorcycle.

This may result in you having an accident.



For optimal performance please use the camera at temperatures between 60°F and 90°F (15.6°C and 32.2°C) and humidities between 20 to 80%.



Do not use the camera near sand as this may damage the camera.



Cautions

Do not fire the flash close to anyone's eyes.

This may cause damage to the person's eyesight.



Do not subject the LCD display to impact.

This may damage the glass on the screen or cause the internal fluid to leak. If the internal fluid comes in contact with your eyes, flush with fresh water and seek medical attention.



A camera is a precision instrument. Do not drop, strike or use excessive force when handling the camera.

This may cause damage to the camera.



Do not use the camera in humid, steamy, smoky, or dusty places.

This may cause fire or electric shock.



Do not immediately remove the battery after a long period of continuous use.

The battery may become warm during continued use; this is normal. Touching a warm battery may cause personal injury.



Do not wrap the camera or place it in cloth or blankets.

This may cause heat to build up and deform the case, resulting in personal injury. Use the camera in a well-ventilated area.



Do not leave the camera in places where the temperature may rise significantly, such as the inside a car.

This may adversely affect the performance of the product.



Before moving the camera, disconnect all cords and cables.

Failure to do this may damage cords and cables, resulting in personal injury or damage to the product.



Notes on Battery Usage

When you use the battery, carefully read and strictly observe the **Safety Instructions** and the notes described below:

- Use only the specified battery (7.4V).
- Avoid extremely cold environments as low temperatures can shorten the battery life and reduce camera performance.
- When you are using a new rechargeable battery or a rechargeable battery that has not been used for an extended period of time (a battery that passed the expiry date is an exception), it may affect the number of images that can be captured. To maximize its performance and lifetime, we recommend that you fully charge the battery and discharge it for at least one complete cycle before use.
- The camera may feel warm after a long period of continuous use. This is normal and not a malfunction.
- If the battery is not to be used for a long period of time, remove it from the camera. If stored for a long time in a fully charged condition, its performance may be impaired.
- Always keep the battery terminals clean.
- Only use the specified battery or its equivalent with this product.
- Properly dispose the battery when it will no longer charge.
- Do not short the terminals of the battery.

Questions?

Call our toll-free customer service number. Look for the insert with this icon:

Or visit www.polaroid.com.



Notes on Handling Polaroid™ ZINK Premium Photo Paper™ and Print Care

We recommend the use of 2x3" Premium ZINK Paper®- purchased separately.

- POLZ2X310 (10 pack)
- POLZ2X330 (30 pack)
- POLZ2X350 (50 pack)

The 2x3" Premium ZINK Paper® offers the following features.

- _ improved quality, borderless, 2x3" color prints
- _ Brighter, sharper images
- _ Improved color balance
- _ Peel-off, sticky-backed photo paper
- _ Prints dry-to-touch
- _ Smudge-proof, water-resistant, tear-resistant photos
- _ Prints using ZINK® Zero Ink® Printing Technology from ZINK Imaging
- _ Works with 2x3 ZINK® compatible Polaroid products

- Keep the photo pack in a cool and dry place.
- Do not leave the photo pack in a place where the temperature is extremely high (e.g. a car or on the beach) for long periods.
- If the photo pack has been kept in a place where the temperature is extremely high or low, leave it at normal room temperature for an hour before starting to print.
- Do not touch or pull the print during printing.
- Do not bend, fold or scratch prints and avoid touching the print surface.
- Do not leave the prints in extremely hot locations (such as on hot sand, concrete or close to a heating appliance).
- Keep the prints in a cool and dry place.
- Do not store the photo pack and prints in moist areas (store them in areas that have less than 20% humidity).

CONTENTS

- 8 INTRODUCTION**
 - 8 Overview
 - 8 Package Contents
- 9 GETTING TO KNOW YOUR CAMERA**
 - 9 Front View
 - 10 Rear View
 - 11 LCD Display
- 13 GETTING STARTED**
 - 14 Installing Polaroid PoGo™ Premium ZINK Paper™
 - 15 Charging the Battery
 - 16 Initial Settings
- 18 CAPTURE MODE**
 - 18 Capturing Images
 - 19 Setting the Self-timer
 - 20 Setting the Scene Mode
 - 22 Setting Manual White Balance
 - 22 Recording Shots into Multiple Image Layout
 - 23 Find Blur Function
- 24 VIDEO MODE**
 - 24 Recording Video Clips
 - 25 Playing Back Video Clips
- 26 PLAYBACK MODE**
 - 26 Playback of Still Images
 - 27 Erasing Images
 - 27 Removing Red-eye
 - 28 Dynamic Lighting Feature
 - 29 DPOF Settings
 - 30 Protecting Images
 - 31 Attaching Voice Memos
- 32 INSTANT DIGITAL PRINTER FUNCTIONS AND FEATURES**
 - 32 Printing
 - 33 Editing your Images
- 36 MENU OPTIONS**
 - 36 Capture Menu
 - 39 Video Menu
 - 40 Playback Menu
 - 42 Setup Menu
- 44 TRANSFERRING FILES TO YOUR COMPUTER**
 - 44 Downloading Your Files
- 45 EDITING SOFTWARE INSTALLATION**
- 46 SPECIFICATIONS**
- 47 APPENDIX**
 - 47 Possible Number of Shots
 - 49 Troubleshooting

INTRODUCTION

Overview

Congratulations on your purchase of your new Polaroid PoGo™ Instant Digital Camera. This camera is a full featured digital camera with built-in full color printer. Take digital images like any other digital camera, review them on this camera, and print just the ones you want.

Package Contents

Carefully unpack your camera and ensure that you have the following items:

- Instant Digital Camera
- Quick Guide
- Software CD-ROM
- USB cable
- Camera strap
- Rechargeable lithium-ion battery
- AC adapter
- AC adaptor plug*4
- 10 sheets 2x3" Premium ZINK Paper™

Optional Accessories:

- SD/SDHC memory card



-
- Accessories and components may vary by retailer.
 - Should any of these components be missing, please call our friendly customer service to assist you.

GETTING TO KNOW YOUR CAMERA

Front View

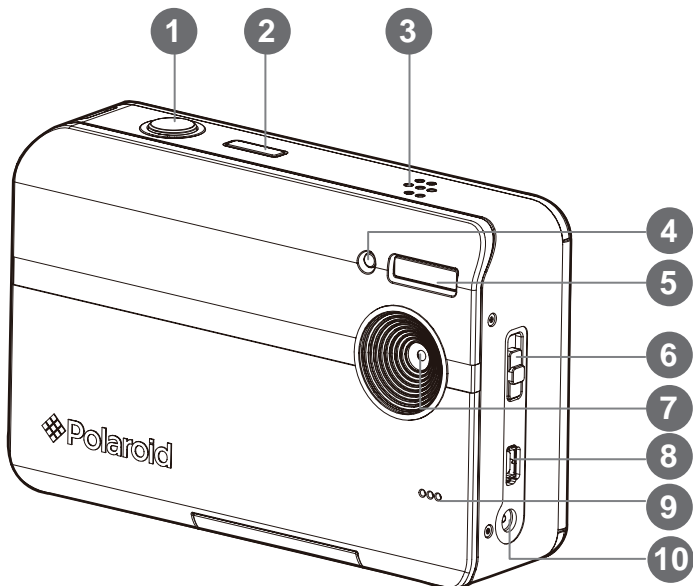

1. Shutter button
2. Power button
3. Speaker
4. Self-timer LED
5. Flash
6. Focus switch
7. Lens
8. USB terminal
9. Microphone
10. DC IN 9V terminal

Rear View

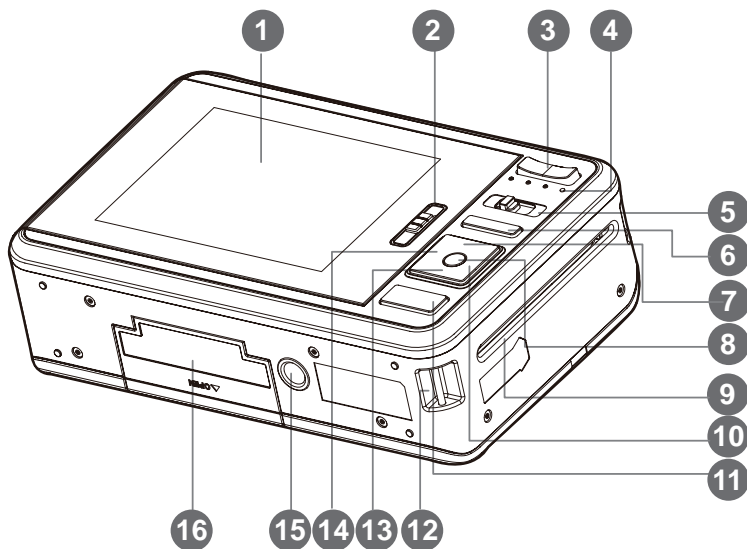

1. LCD display

2. Paper tray door latch

3. Zoom in button
Zoom out button

4. Status LED

5. Mode button

6. Menu button

7. Up button
Display button

8. **OK** Set button

9. Photo exit slot

10. Right button
Flash mode button

11. Print button

12. Hand strap holder

13. Down button
Delete button























14. Left button
Self-timer button

15. Tripod socket









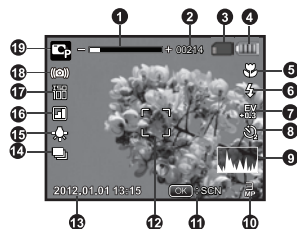

































16. Battery / SD card door

LCD Display

Capture mode

1. Zoom status
2. Available number of shots
3. Storage media
 - [] Internal memory (no card)
 - [] SD/SDHC memory card
4. Battery level
 - [] Full battery power
 - [] Medium battery power
 - [] Low battery power
 - [] No battery power
5. Focus setting
 - [Blank] Normal
 - [] Macro
6. Flash mode
 - [] Auto
 - [] Flash On
 - [] Flash Off
 - [] Red-eye
7. [] Exposure compensation (Adjust exposure compensation value with the ◀ / ▶ buttons)
8. Self-timer & Self-portrait icon
 - [] Off
 - [] 2 sec.
 - [] 10 sec.
 - [] 10+2 sec.
9. [] Histogram
10. Image size resolution
 - [] 3648x2736 (FW interpolation)
 - [] 3264 x 2448 (FW interpolation)
 - [] 2560 x 1920
 - [] 2048x1536
 - [] 640 x 480
11. OK key: **SCN** hint icon
12. Main focus area
13. Date and time
14. Capture mode icon
 - [] Single



- [] Continuous
- [] AEB (Auto Exposure Bracketing)
- [] Album Shot
- [] Burst
- [] Cont.flash
- [] Pre-shot
- [] Coupl.shot
- 15. White balance
 - [] Auto
 - [] Incand.
 - [] Fluoresc.1
 - [] Fluoresc.2
 - [] Daylight
 - [] Cloudy
 - [] Manual WB
- 16. Image quality
 - [] Fine
 - [] Standard
 - [] Economy
- 17. ISO
 - [] Auto
 - [] ISO 100
 - [] ISO 200
 - [] ISO 400
- 18. Slow shutter warning
- 19. Scene mode
 - [] Auto
 - [] Program AE
 - [] Anti-shake
 - [] Fisheye
 - [] Portrait
 - [] Landscape
 - [] Sports
 - [] Night Portrait
 - [] Night Scene
 - [] Candlelight
 - [] Fireworks
 - [] Text
 - [] Sunset
 - [] Sunrise
 - [] Splash Water
 - [] Flow Water
 - [] Snow
 - [] Beach
 - [] Pets
 - [] Photo border
 - [] Natural Green

Video mode

1. Zoom status
2. Storage media
3. Battery level
4. Focus setting
5. Self-timer icon
6. Video resolution
7. Available recording time/Elapsed time during recording
8. Main focus area
9. Date and time
- 10.Video quality
11. Audio off icon
12. Mode icon

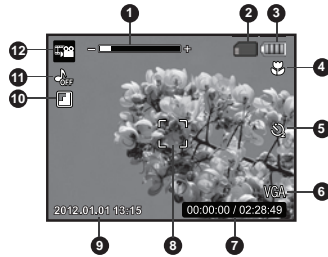

Playback mode - Still image playback

1. Voice memo
2. DPOF icon
3. Protect icon
4. File / Folder number
5. Storage media
6. Battery condition
7. Image size resolution
8. OK key: Play hint icon
9. Date and time
10. Histogram
11. Shutter speed value/Aperture value
12. Exposure value
13. Image quality
14. ISO
15. Mode icon

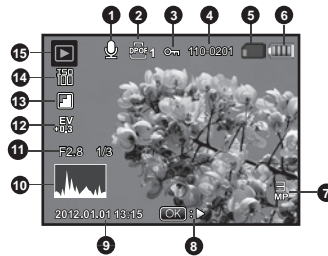

Playback mode - Video playback

1. Protect icon
2. File / Folder number
3. Storage media
4. Battery condition
5. Up key: Volume adjust icon
6. Volume
7. Total recorded time
8. Video status bar
9. Video condition icon
10. Elapsed time
11. OK key: Play/Pause hint icon
12. Down key: Stop hint icon
13. Mode icon

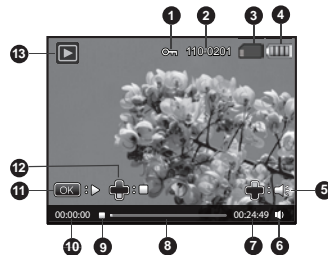

GETTING STARTED

Preparation

1. Attach the camera's hand strap as shown in the illustration.

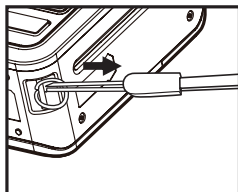

2. Open the battery/SD card door.

3. Insert the battery in the correct orientation as shown in the illustration.

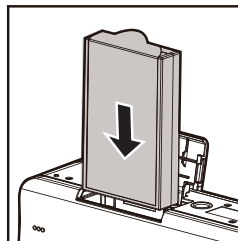

4. Insert an SD/SDHC memory card (Optional).

- The camera has 32MB internal memory (15MB available for image storage), but you can load an SD/SDHC memory card to expand the camera's memory capacity.
- Be sure to format the memory card with this camera before its initial usage.

5. Close the battery/SD card door and make sure it is locked securely.

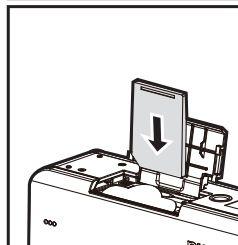

■ To prevent valuable data from being accidentally erased from an SD/SDHC memory card, you can slide the write protect tab (on the side of the SD/SDHC memory card) to "LOCK".

■ To save, edit, or erase data on an SD/SDHC memory card, you must unlock the card.

■ To prevent damaging of an SD/SDHC memory card, be sure

to turn off the power when inserting or removing the SD/SDHC memory card. If inserting or removing the SD/SDHC memory card with the power on, the camera will automatically turn off.

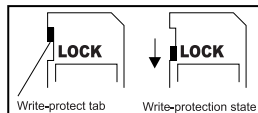

Installing Polaroid PoGo™ Premium ZINK Paper™

Insert the photo paper before printing images.

1. Slide the latch on the paper tray door as shown in the illustration.

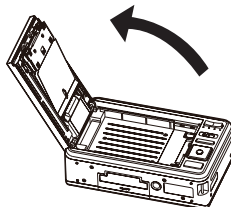
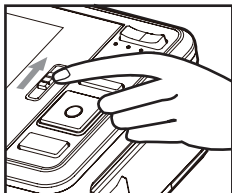

2. Unwrap the 10-pack of Polaroid PoGo™ Premium ZINK Paper™.

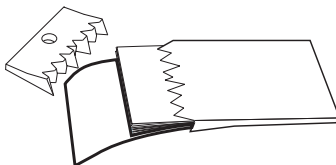

3. Slide the 10-pack of Polaroid PoGo™ Premium ZINK Paper™ into the paper tray.

- Make sure the ZINK Smart Sheet™ is placed and loaded with the bar code face down.
- Shiny side of paper faces up.

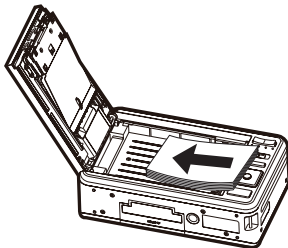

4. Close the paper tray door.

- The ZINK Smart Sheet™ will automatically eject.



-
- The paper compartment must be empty before refilling. Do not fill the paper compartment with more than one 10-pack of Premium ZINK Paper™. Having more than 10 sheets of paper may damage the printer.
 - Avoid bending the Premium ZINK Paper™.
 - Only hold the Premium ZINK Paper™ by its edges; avoid touching the printing surface with your fingers.

Charging the Battery

The AC adapter charges the battery and also powers the camera. Make sure that the camera is turned off and the battery is inserted before starting.

1. Insert one end of the AC adapter into the DC IN 9V terminal of the camera.
2. Insert the other end of the AC adapter into a wall outlet.

- The status LED is red when charging and is green when charging is complete.
- Charging time varies according to the ambient temperature and the age of the battery.

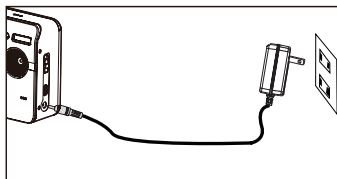

- The battery may feel warm after it has been charged or immediately after being used. This is normal and not a malfunction.
- When using the camera in cold areas, keep the camera and battery warm.

Notes on the AC power cord

AC Power Cord must meet the requirement of countries where you use this projector. Please confirm your AC plug type below and ensure that the proper AC Power Cord is used. Please ensure that your outlet fits the plug.

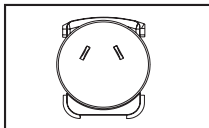

For Australia and Mainland China

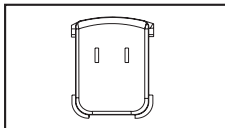

For the U.S.A. and Canada

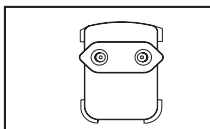

For Continental Europe

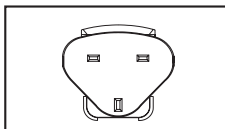

For the U.K.

Initial Settings

Setting the Date and Time

The date/time needs to be set when:

- The camera is turned on for the first time.
- The camera is turned on after leaving the camera without the battery for an extended period of time.

When the date and time information is not displayed on the LCD display, follow these steps to set the correct date and time.

1. Toggle the **MODE** button, and set the camera mode to or ; or press the button.
2. Press the **MENU** button.
3. Select the [Setup] at the end of the Menu with the / buttons, and press the **OK** button.
4. Select [Date/Time] with the / buttons, and press the **OK** button.
5. Select the date format with the / buttons, and press the **OK** button.
 - Select the item's field with the / buttons and adjust the value for the date and time with the / buttons.
 - The time is displayed in 24-hour format.
 - After confirming all settings are correct, press the **OK** button.
6. To exit from the [Setup] menu, press the **MENU** button.



Choosing your Language

Specify what language in the menus and messages are to be displayed on the LCD display.

1. Toggle the **MODE** button, and set the camera mode to [📷] or [📹]; or press the [▶] button.
2. Press the **MENU** button.
3. Select the [Setup] at the end of the Menu with the ▲ / ▼ buttons, and press the **OK** button.
4. Select [Language] with the ▲ / ▼ buttons and press the **OK** button.
5. Select the displayed language with the ◀ / ▶ / ▲ / ▼ buttons and press the **OK** button.
 - The setting will be stored.
6. To exit from the [Setup] menu, press the **MENU** button.



Formatting the Memory Card or Internal Memory

This utility formats the internal memory (or memory card) and erases all stored images and data.

1. Toggle the **MODE** button, and set the camera mode to [📷] or [📹]; or press the [▶] button.
2. Press the **MENU** button.
3. Select the [Setup] at the end of the Menu with the ▲ / ▼ buttons, and press the **OK** button.
4. Select [Format] with the ▲ / ▼ buttons, then press the **OK** button.
5. Select [Confirm] with the ◀ / ▶ buttons, and press the **OK** button.
 - To cancel formatting, select [Cancel] and press the **OK** button.
6. To exit from the [Setup] menu, press the **MENU** button.

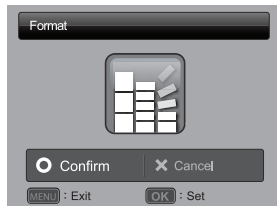





- Photos or movies deleted by formatting cannot be recovered. Download photos and movies to your computer before you format the memory card.

CAPTURE MODE

Capturing Images

Your camera is equipped with a 3.0" full color TFT LCD display to help you compose images, playback recorded images/video clips or adjust menu settings.

1. Press the  button to turn the power on.
2. Toggle the **MODE** button, and set the camera mode to 
 - Set the focus switch to  if you want to capture a close-up image.
 - Toggle the  button to select the appropriate flash mode setting.
3. Compose your image in the LCD display.
 - Pressing the **+** button zooms in on the subject, and enlarges the subject on the LCD display.
 - Pressing the **-** button provides a wider angle image.
4. To take a picture press the shutter button.

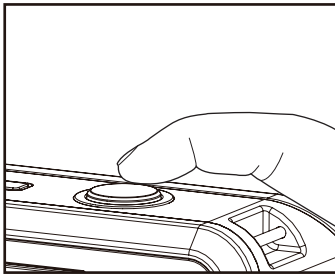

Questions?



Call our toll-free customer service number. Look for the insert with this icon:

Or visit www.polaroid.com.





Setting the Self-timer





This setting allows images to be captured with self-timer.

1. Toggle the  button to select the setting.
 - Each press of the  button moves the icon one step through the sequence and displays it on the screen.
2. Compose your image in the LCD display.
3. Press the shutter button.
 - The self-timer LED flashes and the camera beeps (if beep is turned on). The image will be captured after the preset time has elapsed.
 - The countdown is displayed on the LCD screen.
 - To cancel the self-timer during operation, press the **OK** button or shutter button.

The table below will help you to choose the appropriate self-timer mode:

Self-timer mode	Description
 2s	The image is captured about 2 seconds after the shutter is pressed.
 10s	The image is captured about 10 seconds after the shutter is pressed.
 10+2s	The first image is captured about 10 seconds after the shutter button is pressed, and then a second image is captured 2 seconds later. The 10+2 mode is convenient when capturing group images in succession.



- The "10+2 sec." self-timer function cannot be used in the following capture modes: [], [], [], [], [], [], [], [] and [].
- The self-timer setting is automatically cancelled after an image is captured.







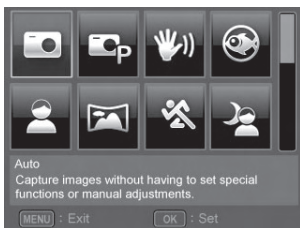



Setting the Scene Mode











By simply selecting one of the available scene modes, you can capture the image with the most appropriate settings.

1. Toggle the **MODE** button, and set the camera mode to [], and press the **OK** button.
2. Select the desired scene mode with the **▲ / ▼** / **◀ / ▶** buttons, and press the **OK** button.
3. Compose your image and press the shutter button.



The table below will help you choose the appropriate scene mode:

Scene mode	Description
 Auto	Select this mode when you want to capture images without having to set special functions or manual adjustments.
 Program AE	Select this mode when you want to set parameters manually other than the shutter speed and the aperture value.
 Anti-shake	Select this mode when you want to minimize the influences of hand shaking when capturing an image.
 Fisheye	Select this mode when you want to simulate a fisheye lens effect or to make a distorted hemisphere-like image.
 Portrait	Select this mode when you want to have optimized settings for Portrait capture.
 Landscape	Select this mode when you want to capture an image with infinity focus, hard sharpness and high saturation.
 Sports	Select this mode when you want to capture fast-moving subjects.
 Night Portrait	Select this mode when you want to capture people with an evening or night scene background.
 Night Scene	Select this mode when you want to capture dark scenes such as night views.
 Candlelight	Select this mode when you want to capture photos of candlelight scene, without spoiling the ambience.
 Fireworks	Select this mode when you want to capture fireworks clearly with optimal exposure. The shutter speed becomes slower, so using a tripod is recommended.

Scene mode	Description
 Text	Select this mode when you want to capture an image that contains black and white subjects like printed documents.
 Sunset	Select this mode when you want to capture a sunset. This mode helps keep the deep hues in the scene.
 Sunrise	Select this mode when you want to capture a sunrise. This mode helps keep the deep hues in the scene.
 Splash Water	Select this mode when you want to capture photos of splashing water.
 Flow Water	Select this mode when you want to capture the soft flowing water.
 Pets	Select this mode when you want to capture your pets. Shoot from their eye level.
 Snow	Select this mode when you want to capture clear snow scenes without darkened subjects and bluish tint.
 Beach	Select this mode when you want to capture bright beach scenes and sunlit water surfaces.
 Photo border	Select this mode when you want to personalize your photo by adding suitable frame to your photo.
 Natural Green	Select this mode when you want to capture the green scenery background such as forest. This mode helps to brighten the colors.

Setting Manual White Balance

This manually sets the white balance and stores it. Use this feature if one of the pre-selected white balance lighting settings does not produce overall good image quality for the lighting used in your image.

1. Toggle the **MODE** button, and set the camera mode to [○].
2. Press the **MENU** button.
3. Select [White Balance] with the ▲ / ▼ buttons, and press the **OK** button.
4. Select [Manual] with the ▲ / ▼ buttons, and press the **OK** button.
5. Select [New WB] with the ▲ / ▼ buttons, and press the **OK** button.
 - To use the previously set white balance data, select [Use Data], and press the **OK** button.
6. Place a white paper in the middle of the scene, with all lights that will be used in the photo turned on. Zoom in on the paper, so it almost fills the frame. Then, select [Confirm] from the Manual WB menu.
 - This establishes for the camera exactly what white should look like under the current lighting conditions, and it will adjust its white balance accordingly.
 - The setting is memorized and will remain if the camera is shut off then back on.

Recording Shots into Multiple Image Layout

The Album Shot mode enables you to easily record images and combine three shots into a single image.

1. Toggle the **MODE** button, and set the camera mode to [○].
2. Press the **MENU** button, and select [Capture Md.] icon with the ▲ / ▼ buttons. Press the **OK** button.
3. Select [Album Shot] with the ◀ / ▶ buttons, and press the **OK** button.
4. Press the **MENU** button.
5. Press the shutter button to capture the first image.
6. Press the shutter button again to capture the second and third images.
 - The camera returns to normal preview display by pressing the ▼ button. Press the ▼ button again to switch back to album shot preview display.
 - This shot can only be recorded if there are 3 shots recorded in each of the available frames.

Find Blur Function

With the camera's new "Find Blur" function, this camera finds the blurry photo when capture under Continuous.

1. Toggle the **MODE** button, and set the camera mode to [📷].
2. Press the **MENU** button, and select [Find Blur] icon with the ▲ / ▼ buttons. Set "Find Blur" on.
3. Press the shutter button to return to preview display.
4. Press the shutter button down fully to capture your image.
5. Press the **OK** (Confirm) button to save the best image.
 - Press the **MENU** (Cancel) button to save all images.

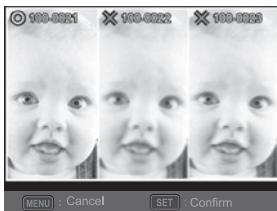

VIDEO MODE

Recording Video Clips

This mode allows you to record video clips at a resolution of 1280x720(30fps) / 320 x 240 / 640 x 480 pixels.

1. Toggle the **MODE** button, and set the camera mode to [📹].
2. Compose the image.
3. Press the shutter button.
 - The recording starts.
 - Pressing the shutter button again and the recording stops.
 - The recording time depends on the available memory on the memory card and the subject of the image being recorded.
 - The zoom function cannot be used during video recording.

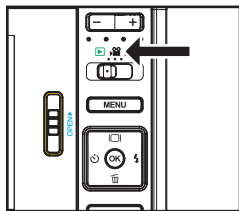

-
- When recording a video clip, the flash and "10+2 sec." self-timer function cannot be used.
 - If the write speed of your SD/SDHC memory card is not fast enough for recording video clips in the currently selected quality, the video recording will stop. Should this happen, select a lower video quality.
 - A video recording will stop automatically when a video clip becomes approx. 4GB or 25minutes.

Playing Back Video Clips

You can play back recorded video clips on the camera. You can also play back sound if recorded with the video.

1. Toggle the **MODE** button to [].
 - The last image appears on the screen.
2. Select the desired video clip with the ◀ / ▶ buttons.
3. Press the **OK** button.
 - A press of the ▶ / ◀ buttons during playback allows fast forward / fast reverse playback.
 - To stop video playback, press the ▼ button.
This stops playback and returns you to the beginning of the video clip.
 - To pause video playback, press the **OK** button.
Pressing the **OK** button again resumes playback.



-
- Video clips cannot be displayed rotated or enlarged.
 - Windows Media player or QuickTime Player is recommended to play back the video clip on your computer.
 - QuickTime Player is a free media player available at www.apple.com; and compatible with Mac and Windows computers.
 - For more information about the operation of the media player, refer to its respective help documentation.
 - When watching a movie on a computer, frames may drop, it may not play smoothing, and the audio may stop suddenly depending on the computer's capabilities.

PLAYBACK MODE

Playback of Still Images

You can play back your still images on the LCD display.

1. Toggle the **MODE** button to [].
 - The last image appears on the screen.
2. The images can be displayed in forward or reverse sequence using the ◀ / ▶ buttons.
 - To view the previous image, press the ◀ button.
 - To view the next image, press the ▶ button.
 - Pressing the + button enlarges the image.
 - To return to normal magnification, press the - button.

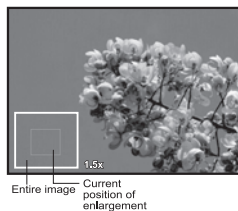
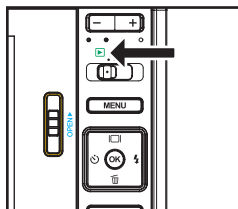

- Video clips cannot be rotated.
- An [] icon is displayed with images which have an audio memo recorded.

Erasing Images

Erasing a single image / Erasing all images

1. Toggle the **MODE** button to [].
 - The last image appears on the screen.
2. Select the image you want to erase with the ◀ / ▶ buttons.
3. Press the **OK** button.
4. Select [Single] or [All] with the ◀ / ▶ buttons, and press the **OK** button.
 - [Single]: Erases the selected image or the last image.
 - [All]: Erases all of the images except for the protected images.
5. Select [Confirm] with the ◀ / ▶ buttons, and press the **OK** button.
 - To not erase, select [Cancel], and press the **OK** button.
6. To exit from the menu, press the **MENU** button.

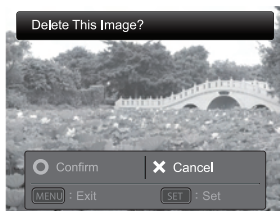

Removing Red-eye

You can use this function to remove the red-eye effect after an image is taken.

1. Toggle the **MODE** button to [].
 - The last image appears on the screen.
2. Select the image that you want to edit with the ◀ / ▶ buttons.
3. Press the **MENU** button.
4. Select [Fix Red Eyes] with the ▲ / ▼ buttons, and press the **OK** button.
5. Select [Confirm] with the ◀ / ▶ buttons, and press the **OK** button.
6. View the changes on the corrected image.
7. To save your corrected image, select [Confirm] with the ◀ / ▶ buttons, and press the **OK** button.
 - When this process ends, this replaces the original image with the corrected image.

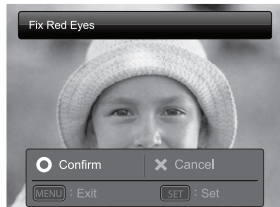

Dynamic Lighting Feature

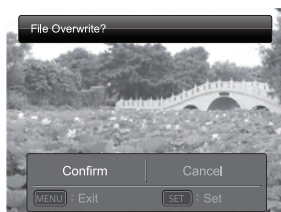

This feature compensates for the unfavorable lighting conditions by brightening underexposed areas and balancing overexposed areas.

1. Toggle the **MODE** button to [].
 - The last image appears on the screen.
2. Select the image that you want to edit with the ◀ / ▶ buttons.
3. Press the **MENU** button.
4. Select [Dynam. Light.] with the ▲ / ▼ buttons, and press the **OK** button.
5. Select [High] or [Low] with the ◀ / ▶ buttons, and press the **OK** button.
6. View the changes on the corrected image.
7. To save your corrected image, select [Confirm] with the ◀ / ▶ buttons, and press the **OK** button.
 - When this process ends, this replaces the original image with the corrected image.



DPOF Settings

DPOF is the abbreviation for Digital Print Order Format, which allows you to embed printing information on your memory card. You can select the images to be printed and how many prints to make with the DPOF menu in the camera and insert the memory card to the card compatible printer. When the printer starts printing, it will read the embedded information on the memory card and print the specified images.

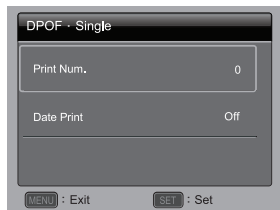
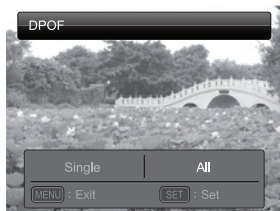
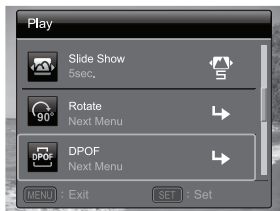

1. Toggle the **MODE** button to [].
 - The last image appears on the screen.
2. Select the image that you want to set DPOF with the ◀ / ▶ buttons.
3. Press the **MENU** button.
4. Select [DPOF] with the ▲ / ▼ buttons, and press the **OK** button.
 - The DPOF setting screen is displayed.
5. Select [Single] or [All] with the ◀ / ▶ buttons, and press the **OK** button.
 - [Single]: Sets DPOF for each individual image.
 - [All]: Sets DPOF for all images at once.
6. Select [Print Num.] with the ▲ / ▼ buttons, and press the **OK** button.
 - This displays the number of prints setting screen.
7. Set the number of prints with the ◀ / ▶ buttons, and press the **OK** button.
8. Select [Date Print] with the ▲ / ▼ buttons, and press the **OK** button.
 - The date setting screen appears.
9. Select date to [On] or [Off] with the ◀ / ▶ buttons, and press the **OK** button.
 - [On]: The date of the image will also be printed.
 - [Off]: The date of the image will not be printed.
 - The DPOF icon () is displayed on each image that has set up DPOF settings.



- The date that is printed on the image is the date set on the camera. To print the correct date on the image, set the date on the camera before you capture the image. Refer to the section in this manual titled "Setting the Date and Time" for further details.

Protecting Images

To prevent images from accidentally being erased, follow the steps below:

1. Toggle the **MODE** button to [].
 - The last image appears on the screen.
2. Select the image that you want to protect with the ◀ / ▶ buttons.
3. Press the **MENU** button.
4. Select [Protect] with the ▲ / ▼ buttons, and press the **OK** button.
5. Select [Single] or [All] with the ◀ / ▶ buttons, and press the **OK** button.
6. Select [Set] with the ◀ / ▶ buttons, and press the **OK** button.
 - Protection is applied to the image and the camera returns to the playback mode.
 - The protect icon [] is displayed with protected images.
When [All] has been selected, [] is displayed on all the images.

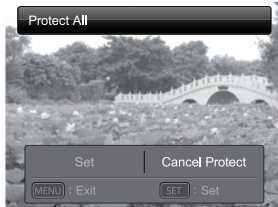
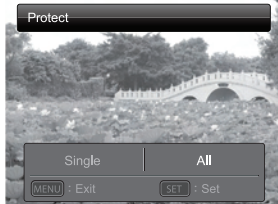
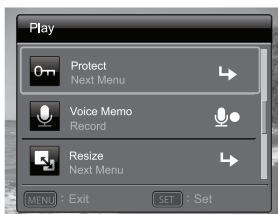

Canceling the Protection

To cancel protection for only one image, display the image on the LCD display you want to remove the protection.



1. Toggle the **MODE** button to [].
 - The last image appears on the screen.
2. Select the image that you want to cancel protection with the ◀ / ▶ buttons.
3. Press the **MENU** button.
4. Select [Protect] with the ▲ / ▼ buttons from the playback menu, and press the **OK** button.
5. Select [Single] or [All] with the ◀ / ▶ buttons, and press the **OK** button.
6. Select [Cancel Protect] with the ◀ / ▶ buttons, and press the **OK** button.
 - The removal of image protection is executed and the camera returns to the playback mode.



- Formatting an SD/SDHC memory card overrides protection, and erases all images regardless of their protected status.

Attaching Voice Memos

You may record a voice memo for a still image (up to 30 seconds in length). Only one voice memo per image.

1. Toggle the **MODE** button to [].
 - The last image appears on the screen.
2. Select the image to which you want to attach the voice memo with the ◀ / ▶ buttons.
3. Press the **MENU** button.
4. Select [Voice Memo] with the ▲ / ▼ buttons, and press the **OK** button.
5. Press the **OK** button.
 -  is displayed on the screen and the recording starts.
6. To stop recording a voice memo as it is being recorded, press the **OK** button again.
 - An  icon is displayed with images that have a voice memo.



- RE-REC mode can only be used for the recorded and selected file, and it can record voice memo repeatedly to replace the previous recordings.

Playing back voice memo



A press of the **OK** button displays  and plays back the voice memo.



- Voice memo is only available for still images.

INSTANT DIGITAL PRINTER FUNCTIONS AND FEATURES

Printing

1. Press the  button to enter the Print mode.
2. Select the image that you want to print with the ◀ / ▶ buttons.
3. Set the number of prints with the ▲ / ▼ buttons, and press the **OK** button.
 - By default the print quantity is 1.
4. Select [Print] with the ▲ / ▼ buttons, and press the **OK** button.
 - Select [Reset] the camera returns to print preview display without saving the settings.
 - Press the **MENU** button to exit print setting, and the camera returns to print preview display.
 - After the printing process is complete, the camera returns to print preview display.
5. Press  to exit print setting, go back to Capture / Movie / Playback mode.

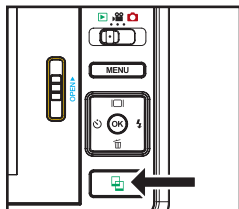

Editing your Images

The camera has features that allow you to perform several photo editing functions on your images before printing. You can remove red-eye effects, crop images to specific sizes and more.

Passport Print

- Press the  button to enter the Print mode, and press the **MENU** button.
- Opt for the [Passport Print] feature with the **▲ / ▼** buttons, and press the **OK** button.
- Select the item's field with the **▲ / ▼** buttons, and press the **OK** button.
- Select the image that you want to edit with the **◀ / ▶** buttons.
- Press the **OK** button again and press the **▲ / ▼** / **◀ / ▶** buttons to select the image portion that you want to crop and press the **OK** button.
- Select [Confirm] with the **◀ / ▶** buttons, and press the **OK** button. The new bordered image is saved as a new file.
 - Select [Cancel] will enter print menu without saving the settings.
- To proceed with image printing, select [Confirm] with the **◀ / ▶** buttons on the "Print Now?" menu.
 - After the printing process is complete, the camera returns to the main Print preview display.

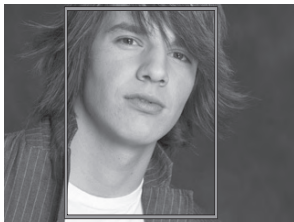

Adding Photo Border

- Press the  button to enter the Print mode, and press the **MENU** button.
- Opt for the [Photo Border] feature with the **▲ / ▼** buttons, and press the **OK** button.
- Select [Add Border] with the **▲ / ▼** buttons, and press the **OK** button.
- Select the image that you want to edit with the **◀ / ▶** buttons.
- Press the **OK** button again and select the photo border that you want to choose with the **◀ / ▶** buttons, and press the **OK** button.
- Select [Confirm] with the **◀ / ▶** buttons, and press the **OK** button. The new bordered image is saved as a new file.
 - Select [Cancel] will enter print menu without saving the settings.
- To proceed with image printing, select [Confirm] with the **◀ / ▶** buttons on the "Print Now?" menu.
 - After the printing process is complete, the camera returns to the main Print preview display.

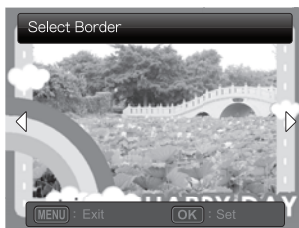

Cropping Images

- a. Press the  button to enter the Print mode, and press the **MENU** button.
- b. Opt for the [Crop] feature with the **▲ / ▼** buttons, and press the **OK** button.
- c. Select the image that you want to edit with the **◀ / ▶** buttons.
- d. Press the **OK** button again to enter the cropping mode. You should see the highlighted crop box.
- e. Press the **+ / -** buttons.
 - Pressing the **+** button enlarges the image.
 - To return to normal magnification, press the **-** button.
- f. Press the **▲ / ▼ / ▶ / ▶** buttons to select the image portion that you want to crop and press the **OK** button.
- g. Select [Confirm] with the **◀ / ▶** buttons, and press the **OK** button. The cropped image is saved as a new file.
 - Select [Cancel] will enter print menu without saving the settings.
- h. To proceed with image printing, select [Confirm] with the **◀ / ▶** buttons on the "Print Now?" menu.
 - After the printing process is complete, the camera returns to the main Print preview display.



Adding Polaroid Border

- a. Press the  button to enter the Print mode, and press the **MENU** button.
- b. Opt for the [Polaroid Border] feature with the **▲ / ▼** buttons, and press **OK** button.
- c. Set "Polaroid Border" on with the **◀ / ▶** buttons, and press the **OK** button.
 - an outline in the standard print selection screen that shows which part of the image will be printed.

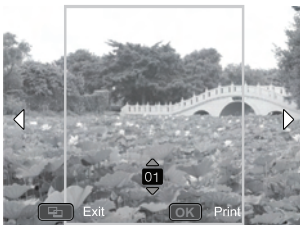

Adding Data Imprint

- a. Press the  button to enter the Print mode.
- a. After selecting your image in the preview mode, press the **MENU** button. Opt for the [Date/File] feature with the ▲ / ▼ buttons, and press **OK** button.
- b. Select the data that you want to print on your image with the ◀ / ▶ buttons, and press the **OK** button.
 - If you wish to print this image, set the number of prints with the ▲ / ▼ buttons, and press the **OK** button.
 - Should you select date or date & file, the print data will be the date the image was taken; not the date the image was printed.



-
- Do not turn off the camera while printing.
 - Do not open the paper tray door while printing.

Questions?

Call our toll-free customer service number. Look for the insert with this icon:

Or visit www.polaroid.com.



MENU OPTIONS

Capture Menu

This menu is for the basic settings to be used when capturing still images.



1. Toggle the **MODE** button, and set the camera mode to [📷].
2. Press the **MENU** button.
3. Select the desired option with the ▲ / ▼ buttons, and press the **OK** button to enter its respective menu.
4. Select the desired setting with the ◀ / ▶ buttons, and press the **OK** button.
5. To exit from the menu, press the **MENU** button.

EV

Your camera adjusts the exposure of each shot automatically. However, if the subject is very dark, or very bright, you may override the camera's automatic exposure setting to make the subject brighter or darker. This is called EV compensation. The EV compensation can be adjusted from -2.0EV to +2.0EV.

Size

This sets the size of the image that will be captured.

* 10M(FW interpolation) / 8M(FW interpolation) / 5M / 3M / VGA

ISO

This sets the sensitivity for capturing images. When the sensitivity is raised (and the ISO number is increased), images taken under low lighting or darker areas of the image will be seen, but the image may be more pixelated/grainier overall. As a "rule of thumb" the higher the ISO value the more grain in the image.

* Auto / ISO 100 / ISO 200 / ISO 400

Quality

This sets the quality (compression) at which the image is captured.

* Fine / Standard / Economy

White Balance

This sets the white balance for a variety of lighting conditions and adjusts the images overall color according to the surrounding light conditions. Use this function if image color appears unnatural.

* Auto / Incand. / Fluoresc.1 / Fluoresc.2 / Daylight / Cloudy / Manual WB

Sharpness

This sets the sharpness of the image that will be captured.

* Hard / Standard / Soft

Color

This sets the overall color of the image that will be captured.

* Standard / Vivid / Color Accent (Red) / Color Accent (Green) / Color Accent (Blue) / Sepia / B&W / Blue / Red / Green / Yellow / Purple

Saturation

This sets the saturation of the image that will be captured.

* High / Standard / Low

Metering

This sets the metering method for calculating the exposure.

- * Center: Averages the light metered from the entire frame, but gives greater weight to the subject matter at the center.
- * Spot: A very small portion of the center of the screen is measured to calculate the correct exposure.
- * Average: The exposure is measured all of the image area.

Capture Mode

This sets the recording method at the time of capturing images.

- * Single: Captures one image at a time.
- * Continuous: Permits continuous capture of up to 3 images.
- * AEB: Permits 3 consecutive images in the order of standard exposure, underexposure and overexposure compensation.
- * Album Shot: Creates an album-like layout to combine 3 shots into a single image.
- * Burst: Permits continuous photography while pressing and holding the shutter button. As long as you hold the shutter button pressed, images are captured until the memory capacity is exhausted.
- * Cont.flash: Permits continuous capture of up to 3 images with flash.
- * Pre-shot: Lets you capture the background first, then have someone to capture you in front of it.
- * Coupl.shot: Uses separate areas to combine two shots. You can include yourself in the shot.

Find Blur

Refer to the section in this manual titled “Find Blur” for further details.

* On / Off

Date Print

The date the image was captured will be printed on it. This function must be activated before the image is captured.

* On / Off

Setup

Refer to the section in this manual titled “Setup Menu” for further details.

Video Menu

This menu is for the basic settings to be used when recording video clips.



1. Toggle the **MODE** button, and set the camera mode to [VGA].
2. Press the **MENU** button.
3. Select the desired option with the ▲ / ▼ buttons, and press the **OK** button to enter its respective menu.
4. Select the desired setting with the ◀ / ▶ buttons, and press the **OK** button.
5. To exit from the menu, press the **MENU** button.

Size

This sets the size of the video clip that will be captured.

* HD / VGA / QVGA

Quality

This sets the quality (compression) at which the video clip is captured.

* Fine / Standard

Color

This sets the color of the video clip that will be captured.

* Standard / Vivid / Color Accent (Red) / Color Accent (Green) / Color Accent (Blue) / Sepia / B&W / Blue / Red / Green / Yellow / Purple

Audio

This sets whether or not to record audio at the time of video recording.

* On / Off

Setup

Refer to the section in this manual titled "Setup Menu" for further details.

Playback Menu

In the [] mode, choose which settings are to be used for playback.

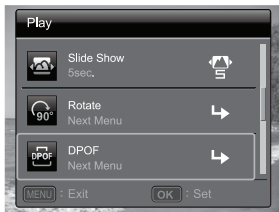
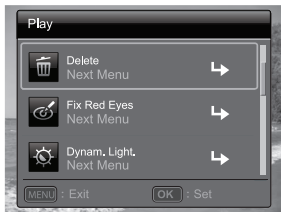

1. Toggle the **MODE** button, and set the camera mode to [].
2. Press the **MENU** button.
3. Select the desired option with the **▲ / ▼** buttons, and press the **OK** button to enter its respective menu.
4. Select the desired setting with the **◀ / ▶** buttons, and press the **OK** button.
5. To exit from the menu, press the **MENU** button.

Delete

Refer to the section in this manual titled “Erasing Images” for further details.

Fix Red Eyes

Refer to the section in this manual titled “Removing Red-eye” for further details.

Dynam. Light.

Refer to the section in this manual titled “Dynamic Lighting Feature” for further details.

Slide Show

This function enables you to play back your still images automatically in order one image at a time.

* 3 Sec. / 5 Sec. / 10 Sec.

Rotate

If you wish to rotate a still image 90 degrees to the right, select +90°; if you wish to rotate it 90 degrees to the left, select -90°. Video clips cannot be rotated.

* +90° / -90°

DPOF

Refer to the section in this manual titled “DPOF Settings” for further details.

Protect

Refer to the section in this manual titled “Protecting Images” for further details.

Voice Memo

Refer to the section in this manual titled "Attaching Voice Memos" for further details.

Resize

Resizes a previously saved image. Resizing replaces the original image with the changed image. It is only possible to resize to a smaller size.

Qual. Change

Changes the quality (compression) of a recorded image. Compress images down to half of their size or less, overwrite old size images with newly compressed images. It is only possible to reduce the image quality/size, never to increase it.

Copy to Card

Allows you to copy your files from the camera's internal memory to a SD/SDHC memory card. Of course, you can only do this if you have a memory card installed and some files in internal memory. All files remain in the internal memory, even after copy to the SD/SDHC memory card from the internal memory.

* Cancel / Confirm

Setup

Refer to the section in this manual titled "Setup Menu" for further details.

Setup Menu

Set your camera's operating environment.



1. Toggle the **MODE** button, and set the camera mode to or ; or press the button.
2. Press the **MENU** button.
3. Select the [Setup] at the end of the Menu with the / buttons, and press the **OK** button.
4. Select the desired option item with the / buttons, and press the **OK** button to enter its respective menu.
5. Select the desired setting with the / buttons, and press the **OK** button.
6. To exit from the menu, press the **MENU** button.

Date/Time

Refer to the section in this manual titled "Setting the Date and Time" for further details.

Language

Refer to the section in this manual titled "Choosing the Language" for further details.

Auto Off

If no operation is performed for a specific period of time, the power to the camera is automatically turned off. This feature is useful for reducing battery usage.

* Off / 1 Min. / 2 Min. / 3 Min.

Beep

This sets whether or not to mute the camera sound each time you press the camera's buttons.

* On / Off

Fr. No. Reset

This creates a new folder. The captured images are recorded to the newly created folder from number 0001.

* Cancel / Confirm

Light Freq.

This camera supports different lighting frequencies: 50 Hz and 60 Hz. When photographing under fluorescent lighting, select the correct frequency setting depending in your local area's voltage.

* 50 Hz / 60 Hz

LCD Bright.

Select a brightness level for the LCD monitor.

* Standard / Bright

Format

Refer to section in this manual titled "Formatting the Memory Card or Internal Memory" for further details.

Media Info.

This displays the free capacity of the internal memory or the memory card.

Sys. Info.

This displays the firmware version of the camera.

Sys. Reset

This returns all basic settings to the camera's default settings. The time setting will not be reset.

* Cancel / Confirm

TRANSFERRING FILES TO YOUR COMPUTER

System Requirement

Windows	Macintosh
<ul style="list-style-type: none">■ Pentium III 1GHz or equivalent■ Windows 2000/XP/Vista■ 512MB RAM■ 150MB available hard disk space■ CD-ROM drive■ Available USB port	<ul style="list-style-type: none">■ PowerPC G3/G4/G5■ OS 9.0 or later■ 256MB RAM (512 MB recommended)■ 128MB available hard disk space■ CD-ROM drive■ Available USB port

Downloading Your Files

1. Turn on your camera.
2. Connect the camera to your computer with the USB cable.
3. Select [PC] using the ▲ / ▼ buttons and press the **SET** button.
4. From the Windows desktop, double click on "My Computer".
5. Look for a new "removable disk" icon.
6. Double click on the removable disk and locate the DCIM folder.
 - Your recorded images and video clips will be inside the folders of DCIM folder.
 - Copy&Paste or Drag-N-Drop image and video files to a folder on your computer.

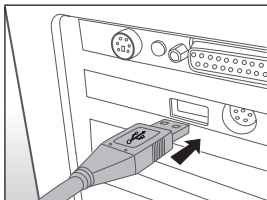

Mac users: Double-click the "untitled" or "unlabeled" disk drive icon on your desktop. iPhoto may automatically launch.



- Black screen appears when camera is connected with PC without battery inside.

EDITING SOFTWARE INSTALLATION

There are 2 types of software that are included on the CD-ROM:

ArcSoft MediaImpression™ - Easily, creatively, and productively manage your multimedia files. Create your own movies or photo slide shows, and share your photo, video and music files easily through simple email attachments or popular photo printing and video sharing websites.

Print Creations - brings you a family of fun and easy print-project software that brings out the creativity in you. You can personalize the designs with your own digital pictures and text based on professionally designed templates and layouts. Projects can be printed at home or saved as image files for sharing with family and friends by email or the web.

To install software:

1. Insert the CD-ROM that came with the camera into your CD-ROM drive.
The welcome screen appears.
2. Click the respective software name.
Follow the on-screen instructions to complete the installation.



-
- For more information about the operation of the software, refer to its respective help documentation.
 - For Windows XP/Vista/7 users, please make sure to install and use the software in "Administrator" mode.
 - The software is not supported by Mac.

Questions?

Call our toll-free customer service number. Look for the insert with this icon:

Or visit www.polaroid.com.



SPECIFICATIONS

Item	Description
Image sensor	1/3.2" CMOS sensor
Image resolution	Still image 10M (3648x2736 FW interpolation); 8M (3264x2448 FW interpolation); 5M (2560 x 1920); 3M (2048x1536); VGA (640x480) Video clip 1280x720(30fps), 640x480, 320x240
LCD display	3.0" full color TFT LCD (230K)
Recording media	32MB internal memory (15MB available for image storage) Supports SD/SDHC memory card (up to 32GB) (optional)
File format	DCF, JPEG (EXIF 2.2), Motion-JPEG (AVI), HD720p/30fps
Lens	Focal length: 6mm
Focus Range	Standard: 1.0m - infinity Macro: 0.19m - 0.24m
Digital zoom	2.4x (Capture mode) 4x (Playback mode)
Flash effective range	1.2~2.1m
Terminals	DV IN 9V USB 2.0 compliant
Power supply	Rechargeable Lithium-ion battery (7.4V) AC adapter (9V/3A)
Dimensions	Approx. 118 x 76x 34.6mm (without protruding parts)
Weight	Approx. 264g (without battery and memory card)















* Design and specifications are subject to change without notice.

APPENDIX







Possible Number of Shots

Possible number of shots (still image)

The table shows the approximate shots that you can capture at each setting based on the capacity of the internal memory and the SD/SDHC memory card.

Size	Quality	Internal Memory	SD/SDHC memory card capacity					
			1GB	2GB	4GB SDHC	8GB SDHC	16GB SDHC	32GB SDHC
10 MP 3648x2736 (FW interpolation)	 Fine	7	486	989	1943	3954	7957	15962
	 Standard	12	725	1476	2899	5900	11871	23814
	 Economy	15	1010	2054	4035	8211	16522	33143
8 MP 3264 x 2448 (FW interpolation)	 Fine	9	560	1140	2240	4559	9174	18404
	 Standard	14	856	1741	3420	6960	14005	28094
	 Economy	18	1155	2349	4613	9389	18891	37895
5 MP 2560 x 1920	 Fine	11	745	1517	2980	6064	12203	24479
	 Standard	18	1146	2331	4579	9318	18749	37612
	 Economy	24	1504	3060	6010	12231	24610	49368
3 MP 2048 x 1536	 Fine	16	998	2030	3986	8113	16324	32746
	 Standard	24	1503	3058	6005	12221	24590	49327
	 Economy	32	2007	4083	8018	16319	32834	65864
VGA 640 x 480	 Fine	47	3012	6126	12028	24478	49251	98797
	 Standard	68	4310	8765	17210	35024	70469	99999
	 Economy	81	5032	10235	20097	40898	82286	99999

Possible recording time / sec (video clip)

Size	Quality	Internal Memory	SD/SDHC memory card capacity					
			1GB	2GB	4GB SDHC	8GB SDHC	16GB SDHC	32GB SDHC
HD 1280 x 720	 Fine	00:00:05	00:06:04	00:12:21	00:24:16	00:49:23	01:39:22	03:19:20
	 Standard	00:00:06	00:06:49	00:13:53	00:27:16	00:55:31	01:51:42	03:44:05
VGA 640 x 480	 Fine	00:00:07	00:07:35	00:15:25	00:30:17	01:01:38	02:04:01	04:08:48
	 Standard	00:00:12	00:13:34	00:27:36	00:54:12	01:50:18	03:41:57	07:25:13
QVGA 320 x 240	 Fine	00:00:21	00:22:25	00:45:36	01:29:33	03:02:15	06:06:42	12:15:36
	 Standard	00:00:31	00:33:16	01:07:40	02:12:53	04:30:26	09:04:08	18:11:31

* The table above shows the approximate maximum recording times. These are the total times for all clips. A video recording will stop automatically when a video clip becomes approx. 4GB or 25minutes.

* We recommend a memory card of at least 10MB/Sec write speed to prevent auto stop or unexpected results. If you experience an error using a slower SD/SDHC memory card, you can set your camera's video recording to QVGA (320 x 240) and standard quality.



* SDHC Class6 or above is required for HD movie recording.

Troubleshooting

Refer to the symptoms and solutions listed below before sending the camera for repairs. If the problem persists, contact your local reseller or service center.

Symptom	Cause	Solutions / Corrective Actions
The camera does not come on.	The battery is not inserted.	Insert the battery correctly.
	The battery is dead.	Recharge the battery.
The battery runs out quickly.	The battery is not fully charged. The battery is not used for an extended period of time after being charged.	Fully charge the battery and discharge it for at least one complete cycle before use to maximize its performance and lifetime.
The battery or camera feels warm.	Long period of continuous use of the camera or the flash.	-----
Even if I press the shutter button, the camera does not take a picture.	The shutter button is not pressed all the way down.	Press the shutter button all the way down.
	The memory card is full.	Insert a new memory card, or delete unwanted files.
	The memory card is write-protected.	Remove the write-protection.
Images do not appear on the LCD display.	LCD display is dark.	Adjust the brightness of the LCD display in the menu.
The images appear to be blurry or out of focus.	The subject is too close.	Get your subject within the effective focus range.
The contents on the memory card cannot be played back.	You played back a memory card that was not formatted by this camera.	Insert a memory card that was formatted on this camera.
Files cannot be deleted.	The file is protected.	Cancel protection.
	The memory card is write-protected.	Remove the write-protection.
Even when the camera's buttons are pressed, it does not operate.	The battery is running low.	Recharge the battery.
The date and time are wrong.	The correct date and time is not set.	Set the correct date and time.
Cannot download images.	The free space on the hard disk in your computer may be insufficient.	Check whether the hard disk has space for running Windows, and if the drive for loading image files has a capacity at least that of the memory card inserted in the camera.
	The battery power may be too low.	Plug in the AC adapter and recharge the battery.

Troubleshooting when using the camera's built-in printer:

Problem	Solution	
	Do not:	Do:
The photo has streaks.	Send another image to be printed.	<ol style="list-style-type: none"> 1. Turn off the camera. 2. Open the paper tray door and remove the photo paper. 3. Place the ZINK Smart Sheet™ upside down (with watermark facing down) in the paper tray. 4. Close the paper tray door. 5. Press the  button to turn the power on. 6. The ZINK Smart Sheet™ will automatically eject. 7. Once The ZINK Smart Sheet™ has ejected, open the paper door and reload the paper. 8. Resume printing. If streaks are still present, then repeat this process.
The paper jammed before printing (nothing has been ejected).	Send another image to be printed.	<ol style="list-style-type: none"> 1. Open the paper tray door. Check if there is paper in the tray. <ul style="list-style-type: none"> ■ If so, ensure the paper is loaded correctly. ■ If not, add a new pack of Polaroid Premium ZINK Paper™.
The paper jammed while printing (part of the image has already ejected).	Pull out paper.	<ol style="list-style-type: none"> 1. Turn off the camera. 2. Open the paper tray door and remove the excess photo paper. 3. Close the paper tray door. 4. Press the print button again. This should eject the jammed paper. 5. Reload the paper after the jammed paper has been cleared.
If all else fails...	-----	<ol style="list-style-type: none"> 1. Turn off the camera. 2. Open the battery/SD card door. 3. Remove the battery and reinsert it. 4. Close the battery/SD card door. 5. Turn on the camera.
Low battery.	-----	Plug the AC adapter to charge the battery and operate the camera to print images.
Out of paper.	Turn off the camera.	Open the paper door and reload a new pack of Premium ZINK Paper to continue printing or the OK button to cancel printing and return to the  menu.