

# Always there to help you

Register your product and get support at  
[www.philips.com/support](http://www.philips.com/support)



BT2200



## User manual

# PHILIPS



# Contents

---

|          |                               |          |
|----------|-------------------------------|----------|
| <b>1</b> | <b>Important</b>              | <b>2</b> |
|          | Important safety instructions | 2        |

---

|          |                               |          |
|----------|-------------------------------|----------|
| <b>2</b> | <b>Your Bluetooth speaker</b> | <b>3</b> |
|          | Introduction                  | 3        |
|          | What's in the box             | 3        |
|          | Overview of the speaker       | 4        |

---

|          |                             |          |
|----------|-----------------------------|----------|
| <b>3</b> | <b>Get started</b>          | <b>5</b> |
|          | Charge the built-in battery | 5        |
|          | Switch on/off               | 5        |

---

|          |                              |          |
|----------|------------------------------|----------|
| <b>4</b> | <b>Use Bluetooth devices</b> | <b>7</b> |
|          | Connect a device             | 7        |
|          | Play from Bluetooth device   | 8        |
|          | Control your phone call      | 8        |

---

|          |                              |          |
|----------|------------------------------|----------|
| <b>5</b> | <b>Other features</b>        | <b>9</b> |
|          | Listen to an external device | 9        |
|          | Adjust volume                | 9        |

---

|          |                            |           |
|----------|----------------------------|-----------|
| <b>6</b> | <b>Product information</b> | <b>10</b> |
|          | Specifications             | 10        |

---

|          |                        |           |
|----------|------------------------|-----------|
| <b>7</b> | <b>Troubleshooting</b> | <b>11</b> |
|          | General                | 11        |
|          | About Bluetooth device | 11        |

---

|          |               |           |
|----------|---------------|-----------|
| <b>8</b> | <b>Notice</b> | <b>12</b> |
|----------|---------------|-----------|

# 1 Important



## Warning

- Never remove the casing of this speaker.
- Never lubricate any part of this speaker.
- Never place this speaker on other electrical equipment.
- Keep this speaker away from direct sunlight, naked flames or heat.

---

## Important safety instructions

- Make sure that there is enough free space around the speaker for ventilation.
- Only use attachments/accessories specified by the manufacturer.
- Use only power supplies listed in the user manual.
- Do not place any sources of danger on the product (e.g. lighted candles).
- Do not place any sources of danger on the apparatus (e.g. liquid filled objects, lighted candles).
- This speaker is designed to be waterproof in compliance with IEC 60529 IPX6.
- Before use in environment subject to water; always securely close the protective cover at the bottom of the speaker.
- After use in environment subject to water; immediately clean the speaker with a soft dry cloth and let it dry in a well-ventilated place away from direct sunlight.



## Note

- The type plate is located on the bottom of the product.

## 2 Your Bluetooth speaker

Congratulations on your purchase, and welcome to Philips! To fully benefit from the support that Philips offers, register your product at [www.philips.com/welcome](http://www.philips.com/welcome).

---

### Introduction

With this speaker, you can

- enjoy audio from your Bluetooth-enabled devices or other external audio devices; and
- control the incoming phone call through Bluetooth connection.

---

### What's in the box

Check and identify the contents of your package:

- Main unit
- USB cable
- Short user manual

## Overview of the speaker

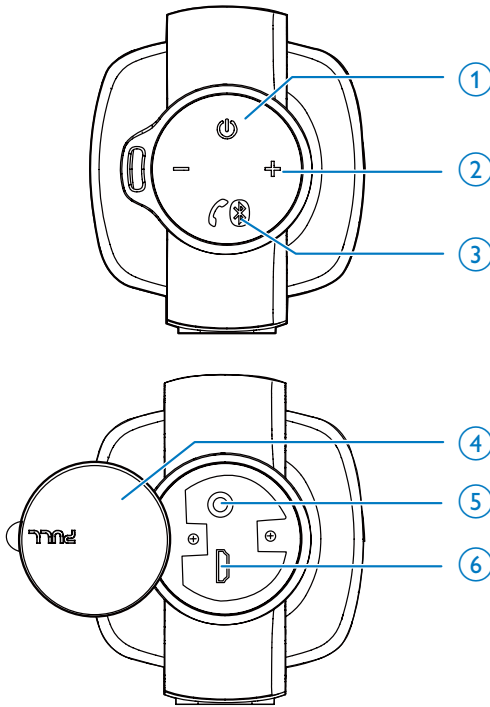

① 

- Press and hold to switch on or off.

② +/-

- Adjust volume.

③ 

- Press and hold for more than 2 seconds to enter pairing mode manually.
- Press and hold for more than 10 seconds to clear pairing information.
- Press to answer an incoming call.

- Press and hold to reject an incoming call.
- During a call, press to end the current call.

④ **Waterproof protective cover**

⑤ **AUDIO IN socket**

- Connect an external audio device.

⑥ **USB charging socket**

- Recharge the built-in battery.

# 3 Get started

Always follow the instructions in this chapter in sequence.

## Charge the built-in battery

The speaker is powered by a built-in rechargeable battery.

### Note

- Before use, fully charge the built-in battery.
- The micro USB socket is for charging only.
- Rechargeable battery has a limited number of charge cycles. Battery life and number of charge cycles vary by use and settings.

- 1 Pull open the protective cover.
- 2 Connect the USB cable between
  - the USB charging socket on the speaker, and
  - a USB socket on a computer.

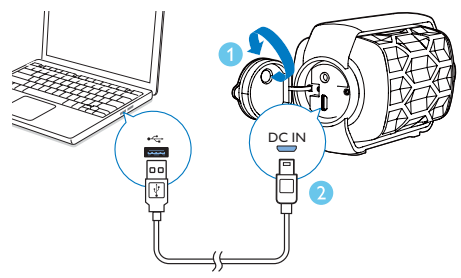

The LED indicator on the  $\phi$  button indicates the battery status.

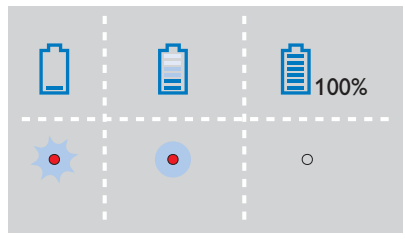

| LED indicator on the $\phi$ button                  | Battery status |
|---|----------------|
| Solid red   | Under charging |
| Off, or solid white when the speaker is switched on | Fully charged  |
| Flashing red  | Low power      |

## Switch on/off

- Press and hold  $\phi$  to switch the speaker on.
  - ↳ The LED indicator on the  $\phi$  button turns solid white.
  - ↳ For first-time setup, the LED indicator on the  $\text{f0}$  button flashes white, indicating that the speaker is in pairing mode.
- To switch off, press and hold  $\phi$  again.
  - ↳ The LED indicator on the  $\phi$  button turns off.

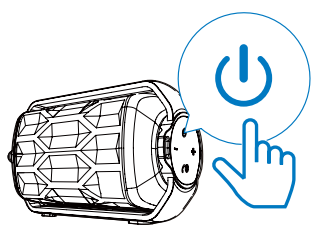

---

## Switch to standby mode

- In Bluetooth mode, if Bluetooth connection is invalid or music playback is stopped for 15 minutes, this speaker switches to standby mode automatically.
  - In AUDIO IN mode, if the audio-in cable is disconnected or music playback is stopped for 15 minutes, this speaker switches to standby mode automatically.
- ↳ To switch on from standby mode, start music play again.



## 4 Use Bluetooth devices



With this speaker, you can listen to audio from Bluetooth-enabled devices and control the incoming call through Bluetooth.

### Connect a device

#### Note

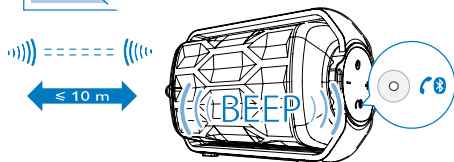
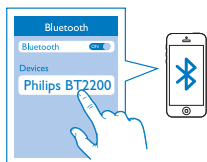
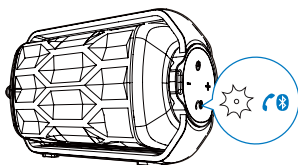
- Make sure that your Bluetooth device is compatible with this speaker.
- Before pairing a device with this speaker, read its user manual for Bluetooth compatibility.
- The speaker can memorize a maximum of 8 paired devices.
- Make sure that Bluetooth function is enabled on your device, and your device is set as visible to all other Bluetooth devices.
- Any obstacle between this speaker and a Bluetooth device can reduce the operational range.
- Keep away from any other electronic device that may cause interference.
- The operational range between this speaker and a Bluetooth device is approximately 10 meters (30 feet).



- 1 Make sure that the speaker is in pairing mode, that is, the LED indicator on the  button flashes white.
- 2 On your Bluetooth device, enable Bluetooth and search for Bluetooth devices (refer to the user manual of the device).
- 3 When **[Philips BT2200]** is displayed on your device, select it to start pairing and connection. If necessary, enter default password "0000".
  - ↳ After successful pairing and connection, the speaker beeps twice, and the LED indicator on the  button turns solid white.

#### To disconnect the Bluetooth-enabled device:

- Disable Bluetooth on your device;
- Press  on the speaker; or
- Move the device beyond the communication range.

#### To clear the existing pairing information:

- Press and hold  for more than 10 seconds.

#### To reconnect the Bluetooth-enabled device:

- For a paired Bluetooth device on which automatic reconnection is enabled, this product reconnects with it once it is detected.
- For a paired Bluetooth device that does not support automatic reconnection, reconnect it with this product manually.

#### To connect another Bluetooth-enabled device:

- Disable Bluetooth on the current device, and wait for around 3 minutes before you connect another device.

| LED indicator on the  button | Description                          |
|---|--------------------------------------|
| Flashing white  | Connecting or waiting for connection |
| Solid white   | Connected                            |

---

## Play from Bluetooth device



### Note

- If there is an incoming call on the connected mobile phone, music play pauses.
- After successful Bluetooth connection, play audio on the Bluetooth device.
  - ↳ Audio streams from your Bluetooth device to the speaker.

---

## Control your phone call

After Bluetooth connection, you can control an incoming call with this speaker:

| Button  | Function  |
|---|---|
|  | Press to answer answer an incoming call.            |
|  | Press and hold to reject an incoming call.          |
|  | During a call, press to end the current phone call. |

### Note

- You can talk through the microphone of the speaker.
- Music play pauses when there is an incoming call, and resumes when your phone call ends.

# 5 Other features

## Listen to an external device

With this speaker, you can also listen to an external audio device such as an MP3 player.

- 1 Pull open the protective cover.
- 2 Connect an audio input cable with a 3.5 mm connector on both ends to
  - the **AUDIO IN** socket on this speaker, and
  - the headphone socket on the external device.

↳ The speaker switches to the **AUDIO IN** source automatically.

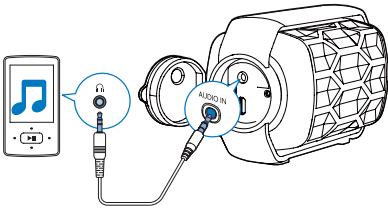

- 3 Play audio on the external device (refer to its user manual).

### Tip

- When you unplug the 3.5mm audio cable, the speaker switches to the Bluetooth source automatically.

## Adjust volume

- Press +/- on the speaker to increase or decrease the volume.

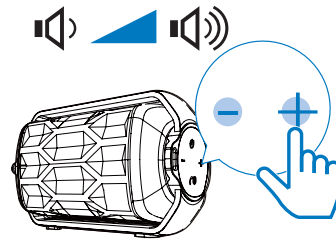

# 6 Product information

## Note

- Product information is subject to change without prior notice.

|                                    |                                   |
|------------------------------------|-----------------------------------|
| Built-in Battery                   | Li-polymer battery (3.7V, 500mAh) |
| Water resistance                   | IPX6                              |
| Operation temperature              | 0°C~45°C                          |
| Storage temperature                | -40°C~70°C                        |
| Dimensions - Main Unit (W × H × D) | 107.3 × 69.1 × 58 mm              |
| Weight - Main Unit                 | 0.2 kg                            |

## Specifications

### Amplifier

|                       |                     |
|-----------------------|---------------------|
| Rated Output Power    | 1 × 2.8W RMS        |
| Frequency Response    | 40 - 20000 Hz, ±3dB |
| Signal to Noise Ratio | > 62dBA             |
| AUX Input sensitivity | 170mV RMS<br>22kohm |

### Bluetooth

|                          |                             |
|--------------------------|-----------------------------|
| Bluetooth version        | V4.0                        |
| Bluetooth Frequency Band | 2.402GHz ~ 2.48GHz ISM Band |
| Range                    | 10 m (Free space)           |

### Speakers

|                   |                         |
|-------------------|-------------------------|
| Speaker Impedance | 4 ohm                   |
| Speaker Driver    | 4 cm full range         |
| Sensitivity       | > 81dB/m/W<br>± 3dB/m/W |

### General information

|                                   |               |
|-----------------------------------|---------------|
| Power Supply (through USB socket) | DC 5 V, 500mA |
|-----------------------------------|---------------|

# 7 Troubleshooting



## Warning

- Never remove the casing of this device.

To keep the warranty valid, never try to repair the system yourself.

If you encounter problems when using this device, check the following points before requesting service. If the problem remains unsolved, go to the Philips Web page ([www.philips.com/support](http://www.philips.com/support)). When you contact Philips, make sure that the device is nearby and the model number and serial number are available.

## General

### No power

- Recharge your speaker.

### No sound

- Adjust volume on the speaker or the Bluetooth-connected device.
- Make sure that your Bluetooth device is within the effective operational range.

### No response from the speaker

- Restart the speaker.

## About Bluetooth device

### The audio quality is poor after connection with a Bluetooth-enabled device.

- The Bluetooth reception is poor. Move the device closer to this product or remove any obstacle between them.

### Cannot connect with the device.

- The Bluetooth function of the device is not enabled. Refer to the user manual of the device for how to enable the function.
- This product is already connected with another Bluetooth-enabled device. Disconnect that device and then try again.

### The paired device connects and disconnects constantly.

- The Bluetooth reception is poor. Move the device closer to this product or remove any obstacle between them.
- For some devices, Bluetooth connection may be deactivated automatically as a power-saving feature. This does not indicate any malfunction of this product.

## 8 Notice

# CE 0700

Hereby, WOOX Innovations declares that this product is in compliance with the essential requirements and other relevant provisions of Directive 1999/5/EC. You can find the Declaration of Conformity on [www.philips.com/support](http://www.philips.com/support).

Any changes or modifications made to this device that are not expressly approved by WOOX Innovations may void the user's authority to operate the equipment.

### Disposal of your old product and battery



Your product is designed and manufactured with high quality materials and components, which can be recycled and reused.



This symbol on a product means that the product is covered by European Directive 2012/19/EU.



This symbol means that the product contains a built-in rechargeable battery covered by European Directive 2013/56/EU which cannot be disposed of with normal household waste. We strongly advise you to take your product to an official collection point or a Philips service centre to have a professional remove the rechargeable battery.

Inform yourself about the local separate collection system for electrical and electronic products and rechargeable batteries. Follow local rules and never dispose of the product and rechargeable batteries with normal household waste. Correct disposal of old products and rechargeable batteries helps prevent negative consequences for the environment and human health.



### Caution

- Removal of the built-in battery invalidates the warranty and may destroy the product.

Always bring your product to a professional to remove the built-in battery.

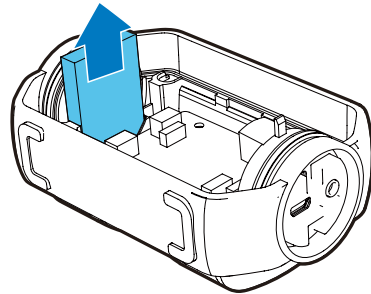

### Environmental information

All unnecessary packaging has been omitted. We have tried to make the packaging easy to separate into three materials: cardboard (box), polystyrene foam (buffer) and polyethylene (bags, protective foam sheet.)

Your system consists of materials which can be recycled and reused if disassembled by a specialized company. Please observe the local regulations regarding the disposal of packaging materials, exhausted batteries and old equipment.



The Bluetooth® word mark and logos are registered trademarks owned by Bluetooth SIG, Inc. and any use of such marks by WOOX Innovations is under license.



2014 © WOOX Innovations Limited. All rights reserved.  
This product was brought to the market by WOOX Innovations Limited or one of its affiliates, further referred to in this document as WOOX Innovations, and is the manufacturer of the product. WOOX Innovations is the warrantor in relation to the product with which this booklet was packaged. Philips and the Philips Shield Emblem are registered trademarks of Koninklijke Philips N.V.

