

OWNER'S MANUAL

PALTM/iPALTM

Portable Audio LaboratoryTM

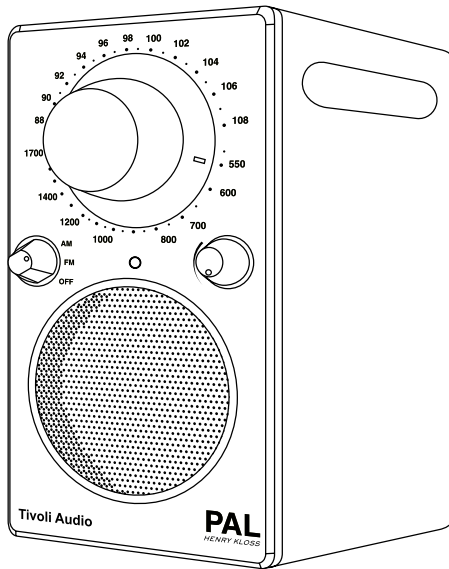

Tivoli Audio[®]

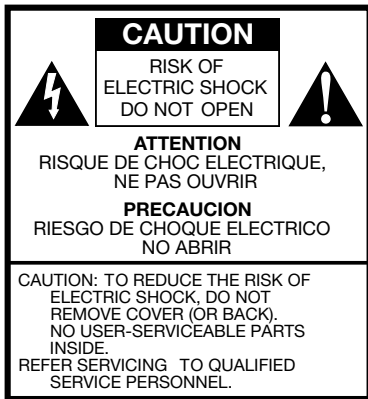

This symbol is intended to alert the user to the presence of uninsulated "dangerous voltage" within the product's enclosure that may be of sufficient magnitude to constitute a risk of electric shock to persons.



This symbol is intended to alert the user to the presence of important operating and maintenance (servicing) instructions in the literature accompanying the appliance.

Important Safety Instructions

1. Read these instructions.
2. Keep these instructions.
3. Heed all warnings.
4. Follow all instructions.
5. Do not use this apparatus near water. For example, do not use near a bathtub, in a wet basement, near a swimming pool, and the like. **WARNING!** Do not expose this product to rain or moisture.
6. Clean only with a dry cloth.
7. Do not block any ventilation openings. Install in accordance with the manufacturer's instructions.
8. Do not install near any heat sources such as radiators, heat registers, stoves, or other apparatus (including amplifiers) that produce heat.
9. Do not defeat the safety purpose of the polarized or grounding-type plug. A polarized plug has two blades with one wider than the other. A grounding type plug has two blades and a third grounding prong. The wide blade or the third prong are provided for your safety. If the provided plug does not fit into your outlet, consult an electrician for replacement of the obsolete outlet.
10. Protect the power cord from being walked on or pinched particularly at plugs, convenience receptacles, and the point where they exit from the apparatus.
11. Only use attachments/accessories specified by the manufacturer.
12. Use only with the cart, stand, tripod, bracket, or table specified by the manufacturer, or sold with the apparatus. When a cart is used, use caution when moving the cart/apparatus combination to avoid injury from tip-over.
13. Unplug this apparatus during lightning storms or when unused for long periods of time.



14. Refer all servicing to qualified service personnel. Servicing is required when the apparatus has been damaged in any way, such as power-supply cord or plug is damaged, liquid has been spilled or objects have fallen into the apparatus, the apparatus has been exposed to rain or moisture, does not operate normally, or has been dropped.
15. This product has been tested and found to comply with the limits for Part 15 of the FCC rules. This device complies with Part 15 of the FCC Rules. Operation is subject to the condition that this device does not cause harmful interference. However, there is no guarantee that interference will not occur in a particular installation. If this equipment does cause harmful interference to radio or television reception, which can be determined by turning the product on and off, the user is encouraged to try to correct the interference by one or more of the following measures:
 - Reorient or relocate the receiving antennas.
 - Increase the separation between the equipment and the receiver.
 - Connect the equipment to an outlet on a circuit different from that to which the receiver is connected.
16. For added protection for this product during a lightning storm, or when it is left unattended and unused for long periods of time, unplug it from the wall outlet and disconnect the antenna or cable system. This will prevent damage to the product to lightning and power-line surges.
17. Operate this product only from the type of power source indicated on the back panel. For products using an external power supply, use an exact replacement if lost or damaged. For products operating from battery power, refer to the user manual.
18. Unplug this product from the wall outlet and refer servicing to qualified service personnel under the following conditions:
 - a. When the power supply cord or plug is damaged.
 - b. If liquid has been spilled or objects have fallen into the product.
 - c. If the product has been exposed to water or rain.
 - d. If the product does not operate normally by following the operating instructions.
 - e. If the product has been dropped or damaged in any way.
 - f. When the product exhibits a distinctive change in performance.
19. Keep this product a safe distance away from naked flame, such as a lit candle.
20. Do not expose this product to splashing or dripping. Objects containing liquid, such as vases or drinking glasses, should not be placed on top of this product.
21. The recommended operating temperature range is 41° F to 104° F (5° C to 40° C).

PAL/iPAL Instructions

Congratulations on your purchase of a truly unique entertainment product. We believe the rechargeable and weather resistant Portable Audio Laboratory (PAL) is one of the finest portable audio products on the market. It is sure to enhance your radio listening experience at home or on the go. Legendary audio inventor Henry Kloss dedicated over half of his life introducing people to the joy of music through his finely crafted, hi-fidelity products. From his classic AR speakers of the 50's, to the Model 8 table radio of the 60's, to the current Tivoli Audio radios, Henry consistently impressed consumers and critics alike with the quality and value of his offerings.

In order to take full advantage of what your new radio is capable of, please take a moment to read this owner's manual and the safety instructions. If you have any questions, please do not hesitate to contact your dealer or Tivoli Audio directly.

Please save the carton and original packing should you ever need to ship your radio, as shipping damage is not covered by the factory warranty.

On behalf of all of us, thank you for choosing Tivoli Audio, and enjoy your new PAL!

About Tivoli Audio

Tivoli Audio was started by Tom DeVesto with the goal of bringing simple to use, high-quality audio products to the consumer. His long professional association with Henry Kloss includes co-founding Cambridge SoundWorks*. As the CEO and head of research and development at his former company, Tom was responsible for many of the best-selling home entertainment and multi-media products on the market today. He also held senior management positions in product development for both Advent and Kloss Video. Tom is uniquely qualified to introduce Henry Kloss' designs.

Portable Audio Laboratory designer Henry Kloss (1929-2002) began his long love affair with audio back in the early 1950's when, as a student at M.I.T., he began building speaker enclosures for fellow students who wanted to exploit the sound of live FM broadcasts of the Boston Symphony Orchestra. With encouragement from the M.I.T. lab staff and Major Edwin Armstrong, the inventor of FM, he co-founded Acoustic Research in 1952. Here, Henry helped develop the revolutionary AR1 acoustic suspension loudspeaker which forever changed the way audio was reproduced. In 1957 he went on to co-found KLH where he introduced audio enthusiasts to the Model Six loudspeaker, Model Eight FM table radio, and Model 11 portable phonograph. Ten years later he founded Advent where, along with great sounding speakers, he produced one of the first projection TVs (which he won an Emmy for) and one of the first consumer cassette decks with Dolby B** noise reduction. Kloss Video entered the picture in 1977. After Kloss Video, Henry co-founded Cambridge SoundWorks in 1988 along with long time associate Tom DeVesto, bringing factory-direct savings in hi-fi and producing the number-one selling multi-media speakers. In 2000, at the age of 70, Henry emerged from retirement to once again team-up with DeVesto to produce the critically acclaimed Model One mono table radio.

*Cambridge SoundWorks is a registered trademark of Creative Labs, Singapore.

**Dolby B is a registered trademark of Dolby Labs, Inc.

Packed with your PAL you should find:

- 1 AC power supply
- 1 Nickel Metal Hydride battery pack (installed)
- 1 warranty registration card
- 1 3.5mm to 3.5 stereo cable (iPAL only)

Please contact your dealer or Tivoli Audio if any of these items are missing.

Tivoli Audio, LLC
Seaport Center
70 Fargo Street, Suite 900
Boston, MA 02210 USA
1.877.297.9479
www.tivoliaudio.com
help@tivoliaudio.com

Before you begin:

For your safety, the PAL is shipped from the factory with discharged batteries. However, it is normal if the PAL plays straight out of the box. With the unit off, connect the power supply to the PAL and plug it into a wall outlet to charge the batteries. (See “Fast Charge Mode”).

Like many rechargeable devices, there may be a delay before the LED starts to blink when the PAL is brand new and first plugged in, or when left unused for several weeks. This is a feature of the Power Management System designed to protect the batteries from damage. Should you experience this, you may “jump start” the “Fast Charge Mode” by playing the PAL (while plugged in) for approximately 2-3 hours and then turning it off (but still plugged in). The green LED should begin to flash at that time indicating Fast Charge Mode is active. In order to complete the charge cycle, leave the PAL plugged in for an additional 4-5 hours even if the LED has stopped blinking.

Bear in mind it may take up to 4 charge/discharge cycles before the batteries are operating at full capacity when the PAL is new or has been unused for several weeks.

Leaving the PAL plugged in even when not in use ensures the batteries will be charged when you need it. If the PAL is not plugged in, the batteries will gradually self-discharge as a safety measure. There is also no harm in playing the PAL continuously while plugged in.

Jump Start:

In the event there is no power from the battery after giving it a full charge, the battery may have self-discharged. In this case, try this simple procedure:

1. Play the PAL at moderate volume for 3 hours while connected to the external adapter.
2. After 3 hours, switch the PAL off. The green power LED should begin to flash indicating the battery is charging.
3. When the LED stops flashing, keep the PAL switched off but leave it plugged into the external adapter for an additional 4-5 hours to complete the charging process.

Guide to Features (Front):

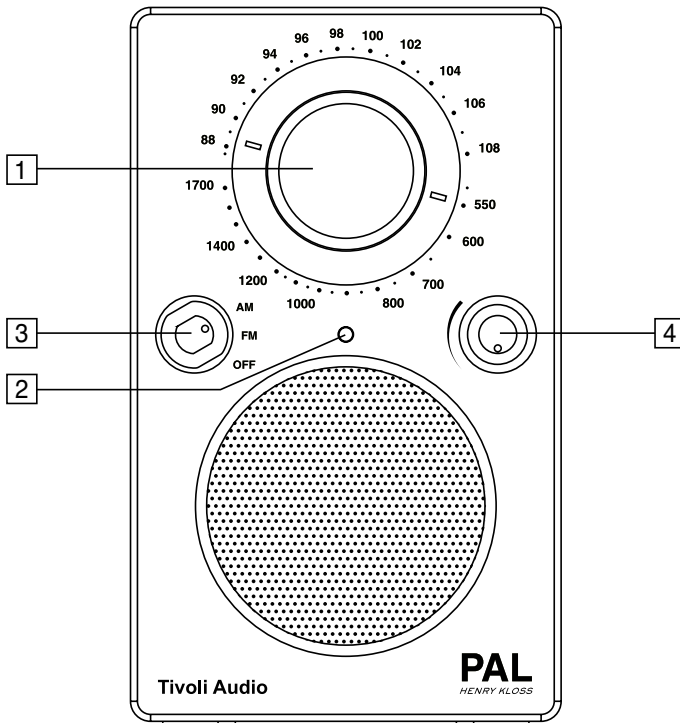

1. **TUNING DIAL:** Turn the analog dial to the right or to the left to change the FM and AM frequency range. The 5:1 tuning gear ratio provides easy, accurate tuning. The FM tuner's Automatic Frequency Control (AFC) locks on to the center of the station for lowest distortion and best reception.
2. **POWER INDICATOR:** Indicates when the unit is on as well as the charging mode and battery status. See the section marked "About the battery pack".
3. **SOURCE KNOB:** Turn the knob 1 click up to select the FM band or 2 clicks up to select the AM band.
4. **VOLUME:** Turn the volume knob up to increase the volume or down to decrease the volume of the PAL's speaker. Since the PAL is portable, please be considerate of others around you when increasing the volume level. This knob will also control the level of headphones (not included) when connected.

Guide to Features (Rear):

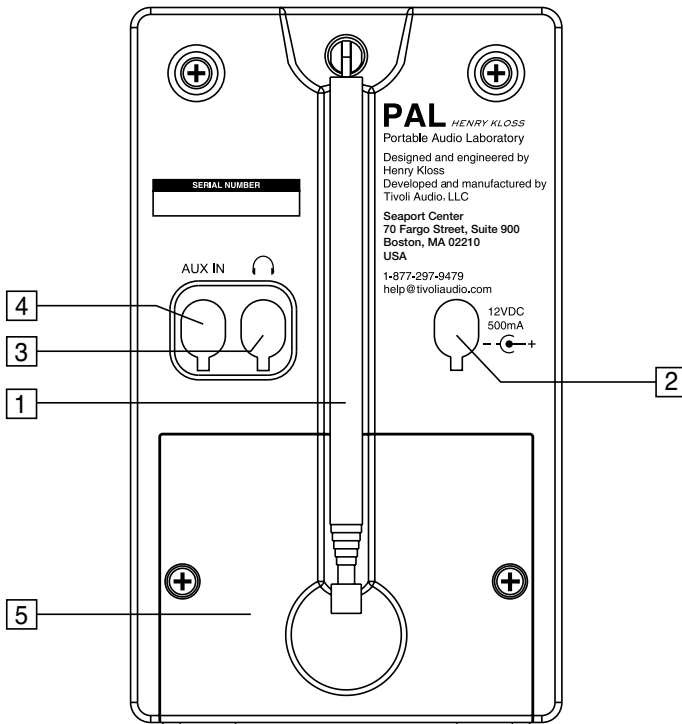

- 1. FM ANTENNA:** When listening to FM, adjust this telescoping antenna and position it for best reception. In strong FM signal locations, reducing the antenna's length may provide better reception. When the unit is not in use or when listening to AM, keep the antenna retracted to protect it. This antenna has no effect on AM reception. For AM, rotate the PAL itself to align the internal antenna for improved reception.
- 2. AC/DC INPUT:** Use this input to operate the PAL using its included PAL-PS Tivoli Audio AC power supply or an optional 12VDC nominal, 500mA fused source. **Use only the power supply provided with this product.** Should the power supply get damaged or misplaced, use only a like replacement. The connector is a 5.5mm/2.1mm center positive connector. Keep the rubber plug inserted when this input is not in use.
- 3. HEADPHONE OUTPUT:** Connect a headset to this stereo output for private listening. The headphone volume will be controlled by the PAL's volume knob. Connecting a pair of headphones will mute the PAL's main speaker. This jack accepts a 1/8" stereo male mini plug. You may also record from the PAL or use it as a high quality stereo tuner by using this output. Keep the rubber plug inserted when this output is not in use.
- 4. AUXILIARY INPUT:** To hear audio from another device (such as a portable CD or MP3 player) through the PAL's main speaker, connect the device's audio output to this input. This jack accepts a 1/8" stereo male mini plug. Note that you may need to adjust the

volume level differently for an auxiliary device than the level normally used for radio listening. Keep the rubber plug inserted when this input is not in use.

- BATTERY COMPARTMENT:** Stores the Nickel-Metal-Hydride battery pack. Do not load any other type of batteries in the compartment. See “Replacing the battery pack.”

Note: We suggest keeping the rubber covers in place over the rear jacks to protect them when not in use.

About the battery pack:

The PAL uses a sealed pack of 6 high capacity Nickel Metal Hydride (NiMH) cells. Unlike Nickel Cadmium (NiCd) batteries, NiMH batteries have no memory effect, provide a longer operating time, and do not use toxic metals. The front panel green LED serves both as a power indicator and battery power and charge status indicator thanks to the PAL's innovative Power Management System.

Fast Charge Mode:

With the PAL turned Off but plugged in, from full discharge, the batteries will be completely charged within approximately 3.5 hours. During this period, the green LED will blink with a long off/short on cycle. The LED will turn off when the batteries are fully charged. Once the PAL has been fully charged using the Fast Charge Mode, do not unplug it and then immediately plug it back in again, as this will restart the Fast Charge Mode even though the batteries are fully charged. Doing this repeatedly will damage the batteries. See also “Before You Begin”.

Trickle Charge Mode:

With the PAL On and plugged in, the batteries will be completely charged in approximately 24 hours. During this period, the LED will remain On continuously.

Low Battery:

With the PAL turned On but not plugged in, as the batteries become discharged, the Power Management System will cause the green power indicator LED to blink with a short off/long on cycle, indicating the batteries are in need of being recharged. The blinking will grow faster as the batteries get closer to discharge until the PAL shuts itself off to protect the batteries. The remaining playback time from the moment the blinking begins until the PAL shuts off is estimated between 20 minutes and several hours. It is difficult to be more precise due to many factors including how long and how loud the radio is played, and the remaining charge left in the batteries. For instance, the PAL will likely play longer off of the batteries at a low volume than at higher volume levels. As you use your PAL, you will develop a better idea of how much playback time you have before recharging is necessary.

If the PAL is turned on to FM or AM and the power indicator is off, then the batteries require recharging. However, it is normal for the radio to play for a brief period if turned on after the LED has gone out.

If the PAL is to be used away from an AC or other power source for an extended period of time, it is wise to “top-off” the charge before use, especially if the LED is blinking.

To do this, follow the procedure described under “Fast Charge Mode”.

Note that the power indicator LED will blink with a different cycle during Fast Charge Mode while the batteries are charging. Because the PAL's NiMH batteries have no memory, it is not necessary to wait until the batteries are exhausted before recharging, although recharging from complete discharge will also do no harm.

Leaving the PAL plugged in, even when not in use, ensures the batteries will be charged when you need them. If the PAL is not plugged in, the batteries will self-discharge as a safety measure. There is no harm in continuously operating the PAL with the power supply.

Note: It may take up to 4 charge/discharge cycles before the batteries are operating at full capacity when new or left unused for several weeks.

Replacing the battery pack:

When it comes time to replace the battery pack, lift the FM antenna up, remove the two screws that hold the battery cover in place with a small Philips-head screwdriver. Lift the battery cover off, disconnect the lead from the battery pack and replace the batteries, making sure to correctly connect the leads. Replace the battery cover by inserting the bottom lip first, then screwing the cover back on. Replacement battery packs may be purchased from your authorized dealer/distributor or Tivoli Audio.

⚠ CAUTION: To reduce the risk of fire or personal injury, use an exact replacement battery pack, available through Tivoli Audio or its authorized dealers, and dispose of the spent battery pack according to your state/country's regulations.

Handling the PAL:

- The PAL is weather resistant, but it is not weather proof. It should not be immersed in water or held under running water. It also should not be exposed to extreme temperatures.
- The PAL is designed to be portable, but it is not indestructible. Do not drop it or subject it to strong impacts.
- Always grip the PAL using the side indentations.
- The PAL's non-slip, weather resistant coating is durable, but it is not impervious to scratches.
- The PAL's speaker is magnetically shielded, permitting use near a computer monitor or a television set.
- It is normal for the power supply to become warm during use.
- Exposing the PAL to extended periods of direct sunlight or heat could damage the rubber coating.

Cleaning:

The PAL's exterior rubber coating is designed to provide a non-slip grip and be water resistant. However, some common chemicals may strip the coating. If something is spilled on the cabinet, wash it off as soon as possible to prevent possible damage. Normal everyday wear and tear, or damage resulting from cleaning or chemicals, is not covered under the factory warranty. To clean the PAL, use water and a soft cloth and do not rub hard. Use a mild soap only when necessary.

Unlike the PAL, the iPAL typically has a water-resistant painted cabinet instead of a rubberized coating. However, it should be handled with the same care.

Headphones:

Avoid using headphones (not included) at high volume levels to prevent possible hearing damage. Do not wear headphones while operating a motor vehicle.

Limited Warranty:

Tivoli Audio manufactures its products to very high standards and we are confident our products will perform well. Accordingly, we provide a limited warranty on this product against manufacturing defects in material and workmanship to the original owner, for a period of one year from the original date of purchase. This warranty is non-transferable.

This Limited Warranty covers the functionality of the product for its normal, intended use as specified in this Owner's Manual. It does not cover a malfunction or damage that has resulted from improper or unreasonable use or installation, faulty ancillary equipment, modifications, unauthorized repair, shipping damage or loss, abuse, accidents, use on improper voltage/current, power surges, lightning or other acts of God, excess moisture, normal wear and tear, commercial use, or purchase from unauthorized dealers. Proof of purchase as evidence the unit was purchased from an authorized dealer may be required for warranty service. **Please contact the dealer of purchase or local distributor for warranty service or repair.**

Returns of any model purchased directly from Tivoli Audio via our website, telephone, mail, or fax: must have a Return Authorization (RA) number clearly indicated on the outside of the package. An RA number can be obtained by phoning Tivoli Audio customer service (1.877.297.9479) with the product's model name, serial number, approximate date of purchase, and detailed description of the problem, or by filling out the RA form on our web site (www.tivoliaudio.com). PRODUCTS RETURNED TO TIVOLI AUDIO WITHOUT A VALID RA # WILL BE RETURNED UNOPENED TO THE SENDER.

Please refrain from opening this product or taking it apart as doing so will void this Limited Warranty. There are no user serviceable parts inside. Tivoli Audio will not pay for costs incurred due to correction of reception problems, elimination of externally generated static/noise, loss of time, inconvenience, loss of use of product, or damage caused by improper use of this product.

In the event the product is returned during the warranty term and is eligible for service under this Limited Warranty, we will repair or replace any defective parts within a reasonable period of time and free of charge.

THIS LIMITED WARRANTY GIVES YOU SPECIFIC LEGAL RIGHTS SUBJECT TO SPECIFIED CONDITIONS. YOU MAY ALSO HAVE OTHER LEGAL RIGHTS WHICH APPLY TO THE PRODUCT YOU HAVE ACQUIRED. SOME PLACES DO NOT ALLOW THE EXCLUSION, RESTRICTION, OR MODIFICATION OF CERTAIN IMPLIED RIGHTS OR THEIR EFFECT. IN THOSE SITUATIONS THIS LIMITED WARRANTY WILL ONLY APPLY TO THE EXTENT THAT THE APPLICABLE LAW ALLOWS.

The provisions of the Limited Warranty are in lieu of any other warranties or conditions, except those provided by law. This Limited Warranty does not affect any legal rights provided to you by law and does not preclude any remedy you may have under law.

In states where liability limits are not precluded by statute, the maximum liability of Tivoli Audio shall not exceed the purchase price paid by you for the product. In states where limitations of liability are precluded by law, Tivoli Audio shall be liable for no more than the direct damages for bodily injury, and/or real or personal property arising from the negligence of Tivoli Audio.

Where not prohibited by law, Tivoli Audio shall not be liable for special, incidental, consequential, or indirect damages. Some places do not allow limitations on the exclusion or limitation of relief, special, incidental, consequential or indirect damages, or the limitation of liability to specified amounts, so the above limitations or exclusions may not apply to you.

This Limited Warranty is void if the label bearing the serial number has been removed or defaced.

For service outside the USA, please contact your local distributor.

If you purchased an extended service contract from your dealer and service is required after the term of this Limited Warranty has expired, please contact your extended service contract provider to obtain service.

For your convenience, you may register your product for warranty service online at our website, www.tivoliaudio.com. There is no legal obligation for you to provide personal information. However, such information allows us to maintain a record of the Tivoli Audio products acquired by you and better understand the purchasers of our products. The information collected will be used for marketing purposes by Tivoli Audio and, where permitted, to contact you in relation to the products you have acquired or other products which might be of interest to you from Tivoli Audio or other companies. The information that you provide may be processed in another country.

Please visit the Tivoli Audio FAQ section at www.tivoliaudio.com prior to any request for warranty service as information available there may answer your questions or concerns.

You may email questions to us at mail@tivoliaudio.com

Specifications:

Model:	Portable Audio Laboratory (PAL) / iPAL
Type:	Portable, weather resistant AM/FM radio
Driver:	1 x 2.5" treated, magnetically shielded, full range driver
Power:	12VDC nominal - 15VDC maximum, 500mA
Battery Pack:	NiMH, 7.2V, 1400-1800mA
Battery Current:	500mA
AC Adapter:	Model PAL-PS: UL: 120V-60Hz, 18W, 12VDC, 500mA, 6VA CE: 230V-50Hz, 15W, 12VDC, 500mA, 6VA
Dimensions:	3 11/16"W x 6 1/4"H x 3 7/8"D
Weight:	2lbs

All specifications subject to change without notice.

Tivoli Audio reserves the right to make product changes without notice.

Tivoli Audio, the Tivoli Audio logo, PAL, iPAL and The Henry Kloss Portable Audio Laboratory are trademarks of Tivoli Audio, LLC.

This manual was written by Peter Skiera and cannot be reproduced in whole or in part without the permission of Tivoli Audio. The information included within this owner's manual was accurate at the time of printing. Tivoli Audio shall not be held liable for operational, technical, or editorial errors/omissions.

For more information about other exciting products from Tivoli Audio, please visit our website or contact us directly:

Tivoli Audio, LLC
Seaport Center
70 Fargo Street, Suite 900
Boston, MA 02210 USA
1.877.297.9479
www.tivoliaudio.com
help@tivoliaudio.com

PALiPALNA1009

Tivoli Audio[®]