



VITAMIX TOTAL NUTRITION CENTER®

Owner's Manual

Read and save these instructions



Vita-Mix® Corporation

8615 Usher Road

Cleveland, OH 44138-2103 U.S.A.

+1 800 848 2649 / +1 440 235 4840

vitamix.com • vitamix.co.uk • vitamix.ie

CONTENTS

Contents	2
Let's get started.....	3
Service and Registration	4
Important Instructions for Safe Use	5
Parts and Features	8
Control Panel	10
About the Blades.....	11
Tamper	12
How to Use the Tamper.....	14
Hints for Setting Speeds	15
Operating Instructions	16
Care and Cleaning	18
Troubleshooting	20
Warranty.....	21
Specifications.....	24

LET'S GET STARTED

Congratulations!

You are about to see how quick, easy and delicious healthy eating can be!

Please read all the safety information, warnings and instructional material found in this booklet before getting started. Set your Vitamix machine on a dry, level surface. Make sure the power switch is set to OFF and that the machine is plugged into an earthed electrical outlet. Then, follow the cleaning instructions on page 18 to prepare your machine for use. Always clean your machine before you first use it.

SERVICE AND REGISTRATION

Vitamix Service

Record the model number and serial number of your Vitamix in the spaces provided below for future reference. These numbers can be found on the back of the motor base.

Model Number _____

Serial Number _____

Date of Purchase _____

Purchased From _____

Before returning this product for any reason, including repair, first contact Vitamix Customer Services on +1 440 235 4840 or e-mail service@vitamix.com
Tel. UK: 0808 156 6633, Tel. Ireland: 0766 709854 or contact your local dealer.

Product Registration

If you purchased your Vitamix® machine directly from the Vita-Mix® Corporation via the company's website or call centre by phone, your product was registered at the time of purchase and your Vitamix machine's warranty has been activated.

If you purchased your Vitamix machine from an International Distributor or Dealer in countries other than the United States, Canada, the United Kingdom or Ireland, your product is warranted through the International Distributor or Dealer and need not be registered with the Vita-Mix Corporation.

Your machine is not yet registered with Vitamix if you:

1. Purchased from a Dealer in the United States, Canada, United Kingdom or Ireland
2. Purchased from a military base
3. Purchased from a retail or wholesale outlet
4. Received your Vitamix machine as a gift
5. Are not the original owner of the machine

Enjoy faster and easier service in the future by taking a few minutes to register your Vitamix machine today.

Choose one of these easy ways to register your machine:

1. Online at vitamix.com/warranty
2. E-mail service@vitamix.com
3. Call +1 800 848 2649 or +1 440 235 4840, press option 2

Your warranty may be honoured by Vita-Mix® Corporation or an authorised dealer.

Failure to register your machine will not diminish your warranty rights.

IMPORTANT INSTRUCTIONS FOR SAFE USE

⚠WARNING



To Avoid Injury.

Read and understand the instruction manual before using this machine. Basic safety precautions should be followed, including the following.



1. Read all instructions, safeguards and warnings before operating the blender.
2. This blender is intended for HOUSEHOLD USE ONLY and is not intended to be used to prepare food for commercial sale or for any other commercial use.
3. This blender is intended to be used in household applications in addition to use in farmhouses and by clients in hotels, motels, bed and breakfast establishments and other residential-type environments.
4. This blender is not intended for use by persons with reduced physical, sensory or mental capabilities, or lack of experience and knowledge, unless they have been given supervision or instruction concerning use of the appliance by a person responsible for their safety.
5. This blender is not intended for use by children, and close supervision is necessary when used near children. Children should be supervised to ensure that they do not play with the blender.

⚠WARNING



Electrical Shock Hazard.

Use an earthed outlet only.

DO NOT remove the earth.

DO NOT use an adaptor.

DO NOT use an extension cable.

Failure to follow instructions can cause death or electrical shock.

6. Operate only when the blender is on a flat and stable surface, free from standing water. Do not let the container, motor base or power cable touch hot surfaces or hang over the edge of a table or counter.
7. Do not fill the container beyond its stated capacity. The maximum capacity is marked on the container.
8. Always begin blending with lid and lid plug firmly in place. Do not operate the blender with the lid removed. The lid plug should be removed only when adding ingredients and when using the tamper.

IMPORTANT INSTRUCTIONS FOR SAFE USE

9. The tamper fitting your container can only be used when the lid is firmly locked in place. Use the lid and the tamper that fit your container. Lids and tampers are not interchangeable between different container styles, types and sizes. If a tamper came with your container, it is the correct tamper for use with the container.
10. Always start the blender with the Variable-Speed dial set to 1 and the High/Low switch in the Low position. To avoid possible burns, never start on speeds above 1 or with the High/Low Switch in the High position when blending hot liquids. Always blend hot liquids with the lid and lid plug firmly in place. Keep hands and other exposed skin away from the lid plug when blending hot contents.
11. Never touch moving parts. Switch off the appliance and wait until the blades stop moving before removing the container from the motor base and opening the container.
12. Switch off the appliance and unplug before changing accessories or approaching parts that move during use.
13. Do not leave or store foreign objects, such as spoons, forks, knives or the lid plug, in the container. Starting the blender with a foreign object in the container will damage the blender and may cause injury.

⚠ WARNING



Electrical Shock Hazard.

Always unplug before cleaning the motor base or when not in use.

Do not put the motor base in water or other liquid.

Failure to follow instructions can cause death or electrical shock.

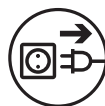

14. Do not operate the blender with a damaged cable or plug. If the supply cable is damaged, it must be replaced by the manufacturer, their service agent or similarly qualified persons in order to avoid a hazard.
15. Blades are sharp. To avoid injury, use extreme care when emptying the bowl and during cleaning.
16. Keep hands and utensils out of the container while blending to reduce the risk of severe injury to persons or damage to the blender. A rubber scraper or spatula may be used, but only when the container is removed from the motor base and the blades are not moving.
17. Do not operate with loose or damaged blades. Do not remove the blade assembly from the container. Contact your nearest Vitamix authorised service representative for service or replacement.

IMPORTANT INSTRUCTIONS FOR SAFE USE

18. Do not use outdoors.
19. When making nut butter or oil-based food, do not process for more than one minute after the mixture starts to circulate in the container. Processing for longer periods can cause damage to the container and overheating of the motor.

⚠️ WARNING



Electrical Shock Hazard, Risk of Fire or Injury.

Do not alter or modify any part of the motor base or container.

Do not use attachments not expressly authorised or sold by Vitamix.

Failure to follow instructions can cause electrical shock, fire or injury.

SAVE THESE INSTRUCTIONS

NOTICE: FAILURE TO FOLLOW ANY OF THE IMPORTANT SAFEGUARDS AND IMPORTANT INSTRUCTIONS FOR SAFE USE IS A MISUSE OF YOUR VITAMIX BLENDER THAT CAN VOID YOUR WARRANTY AND CREATE THE RISK OF SERIOUS INJURY.

PARTS AND FEATURES

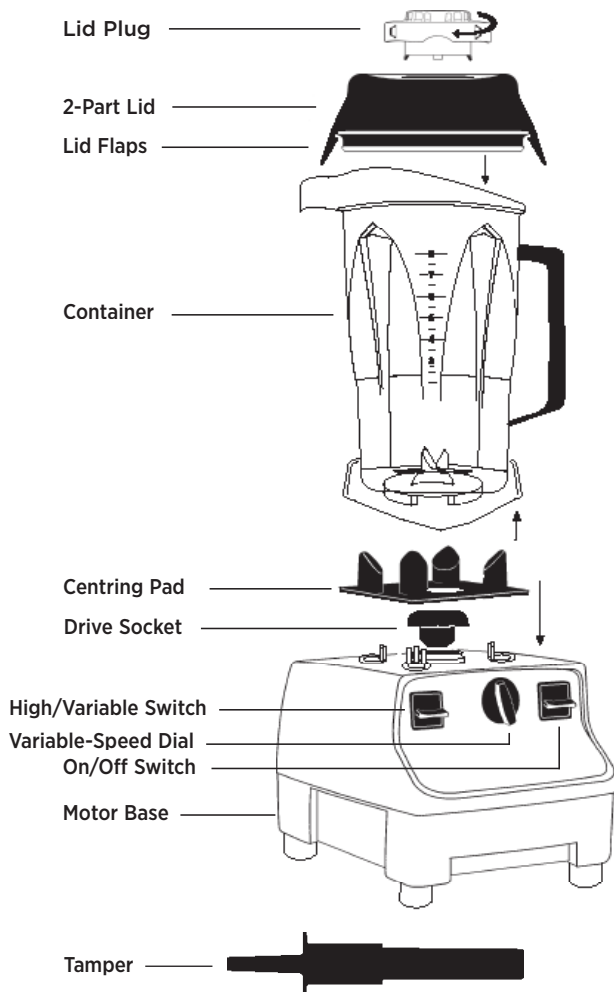

On/Off Switch: Always start the machine with the High/Variable switch in the Variable (\triangleleft) position and the Variable-Speed Dial pointed to 1. Lift the On/Off Switch to the On position (I) to begin blending. Press the switch to the Off position (O) to stop blending.

High/Variable Switch: Variable (\triangleleft) allows use of the Variable-Speed Dial. High (\triangle) is the fastest speed available.

Variable-Speed Dial: The Variable-Speed Dial selects blade rotation speeds from 1 to 10 (low to high).

PARTS AND FEATURES

Container: Millilitres, ounces and cups are clearly marked.



 **CAUTION:** Lids and tampers are not interchangeable between different container styles, types and sizes.

2-Part Lid: The 2-part Lid is easy to put on and take off, and easy to clean. Always use the lid and the lid plug during blending.

Snap the lid onto the container and leave in place for a few minutes. Once the lid has been left on the container, it will be much easier to lock or remove.

Lid Plug: Insert through the lid and secure by turning clockwise. Remove the lid plug to use the tamper or to add ingredients.

Tamper: The tamper allows you to accelerate the process of very thick and/or frozen mixtures that cannot be processed in a standard blender. Using the tamper maintains circulation by preventing air pockets from forming during blending.

 WARNING		
	<p>Rotating Blades Can Cause Severe Injury.</p> <p>DO NOT reach into the container while the machine is running.</p>	

To Lock the Lid in Place: Position the lid on the container with the lid flaps midway between the spout and the handle. Push the lid onto the container until it locks into place. The lid must always be secured when processing, especially when blending hot liquids that may scald. **Never operate the blender without checking to make sure that the lid is securely locked in place.**

To Remove the Lid: Lift up one lid flap while holding the container securely.

To Remove the Lid Plug: Rotate the lid plug anti-clockwise from the “locked” to “unlocked” position and lift out.

Power Cable: Your machine is equipped with a long power cable. Store the unused portion neatly underneath.

Bottom View/Cable Wrap: Plastic cable retainers hold the cable securely. There is no need to unscrew the cable retainers to let out more cable. They are flexible and return to position after the cable is lifted out.

Automatic Overload Protection: Refer to Troubleshooting on page 20.

CONTROL PANEL

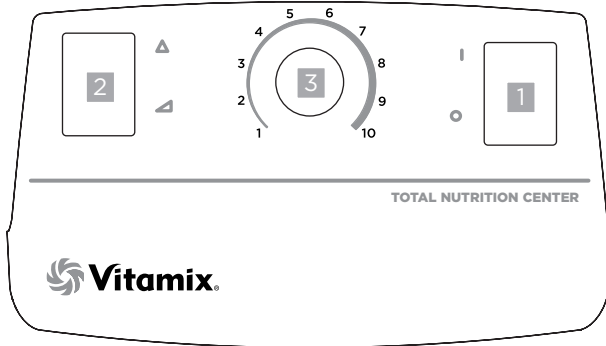

1. **On/Off Switch:** Push up to turn On (I). Push down to turn Off (O).
2. **High/Variable Switch:** High (Δ) is the fastest speed available. Switch to Variable (◁) to activate the variable speeds. **Always make sure that the High/Variable Switch is set to Variable (◁) before lifting the On/Off Switch to the On (I) position.** Do not start your machine on High (Δ) speed.
3. **Variable Speed Dial:** Selects many speed settings. It is active only when the High/Variable Switch is set to the Variable (◁) position.

ABOUT THE BLADES

The wet-blade container comes as standard with the Vitamix machine. The blade is identified by a “W” for wet. This blade is used for most of your recipes.

⚠ WARNING



Rotating Blades Can Cause Severe Injury.

DO NOT reach into the container while the machine is running.



Wet-Blade Container: Designed for processing liquids, including juice, frozen mixtures, sauces, soup, purées, batter, and for wet chopping. The wet blades can also process grain and knead dough, but they are not quite as efficient as the dry blades in this application. See instructions for dry container use.



Dry-Blade Container: These blades are clearly marked “D” and are designed specifically for processing dry materials such as grains, cereal and coffee, and are also used for kneading bread dough. The dry blades **CANNOT** process liquids efficiently. **If you prepare herbs on a regular basis, you may wish to purchase a separate dry-blade container.**

⚠ CAUTION



Moving Parts May Become Hot with Extended Use.

DO NOT touch.



TAMPER

⚠CAUTION



Rotating Blades Can Cause Damage.

Lids and tampers are not interchangeable between different container styles, types and sizes. Use the tamper that was supplied with your machine.

How to Determine the Tamper to be Used with Your Container

Each type of tamper is designed to be used safely and effectively with a particular container. **If a tamper came with your container, it is the correct tamper for the container.** If a tamper did not come with your container or you want to determine if a tamper that you already have can be used with your new container, please compare your container with the containers and matching tampers in the illustration below.

Before using the tamper during the blending process, verify that it is the correct tamper.

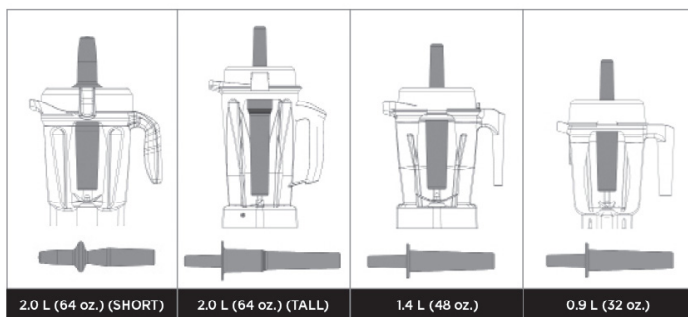

- 2.0 L (64 oz.) Short Containers use Tamper 016041, which is approximately 24.8 cm (9-¾ inches) long.
- 2.0 L (64 oz.) Tall Containers uses Tamper 000760, which is approximately 31.8 cm (12-½ inches) long
- 0.9 L (32 oz.) and 1.4 L (48 oz.) Containers use Tamper 015033 that is approximately 27.9 cm (11 inches) long.

TAMPER

To verify that you are using the correct tamper, place the lid on an empty container, remove the lid plug and insert the tamper. If it is the correct tamper, it should fit easily into the opening, but should not come into contact with the blades no matter where you move the tamper inside the container. IF THE TAMPER TOUCHES THE BLADES AT ANY ANGLE - DO NOT USE THE TAMPER WITH YOUR CONTAINER.

If you do not have the correct tamper for your container, call Vitamix Customer Services on +1 800 848 2649 or +1 440 235 4840, or e-mail service@vitamix.com to order a new tamper. If purchased outside the United States or Canada, contact your local Vitamix Dealer.

HOW TO USE THE TAMPER

⚠WARNING



Rotating Blades Can Cause Severe Injury.

- **DO NOT** put hands, spatulas etc. into the container while the machine is running or while the container is still on the base.
- Lids and tampers are not interchangeable between different container styles, types and sizes. Use the tamper that was supplied with your machine.



IMPORTANT:

- The splash disc (near the top of the tamper) and lid prevent the tamper from hitting the blades when the lid is secured properly in the locked position.
- The container should not be more than two-thirds full when the tamper is used during blending.
- To avoid overheating during blending, **DO NOT** use the tamper for more than 30 consecutive seconds.
- If the food does not circulate, the machine may have trapped an air bubble. Carefully remove the lid plug, while making sure the lid stays firmly in place. Release the air bubble by inserting the tamper through the lid plug opening.
- Holding the tamper straight down may not help the ingredients circulate. If necessary, point the tamper towards the sides or corners of the container. **DO NOT** try to force the tamper more deeply into the container.

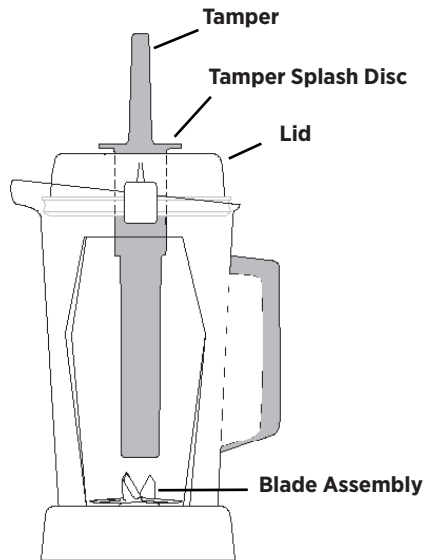

HINTS FOR SETTING SPEEDS

Always start the machine with the left switch down in the Variable (\triangleleft) position and with the centre Variable-Speed Dial on 1. Slowly turn the Variable-Speed Dial to the desired speed depending on the recipe used. If a recipe calls for processing on High (\triangle), slowly rotate the Variable-Speed Dial to 10 and then push the High/Variable Switch up into the High (\triangle) position. **Do not begin processing on Variable 10 or directly on the High (\triangle) setting.**

Process on the High (\triangle) setting for as much of the processing time as possible to make whole food juices, soups, shakes, frozen mixtures, purées, nut butters and for grinding grains. Processing times will generally be less than one minute (most take less than 30 seconds). High (\triangle) speed provides the best quality of refinement, breaking down ice, frozen fruit, whole fruits or vegetables, and grains to a smooth lump-free consistency.

TIP: Blending for too long at too low a speed setting will overheat the machine and cause the Automatic Overload Protection to turn off the machine. Use the High (\triangle) speed as often as possible to achieve the most uniform consistency. Blending on High (\triangle) speed also maximises the motor's cooling fan to avoid overheating.

When on the High (\triangle), if the food does not circulate, the machine may be overloaded or may have trapped an air bubble. Carefully remove the lid plug, while making sure the lid stays firmly in place. Release the air bubble by inserting the tamper through the lid plug opening. If circulation problems continue, reduce the machine speed. A lower speed may allow food to circulate when a higher speed does not. Once the food is circulating freely, increase the speed back to High (\triangle) and continue processing.

⚠ CAUTION



To Avoid Possible Burns, Never Start on Speeds Above 1 when Processing Hot Liquids.

Escaping steam, splashes or contents may scald.

To secure the contents, lock the lid and lid plug securely in place prior to operating the machine.

Always start on Variable-Speed 1 and slowly increase to 10.



OPERATING INSTRUCTIONS

Wet-Blade Container

Designed for processing liquids including juice, frozen mixtures, sauces, soups, purées, batters, and for wet chopping.

1. Make sure that the Variable-Speed Dial is set to 1.
2. Load the container before placing it on the motor base. Place liquids and soft foods in the container first, then solid items and, finally, ice. Although not necessary for blending, you may want to cut or break food into smaller pieces for more precise measuring of ingredients.
3. Fasten the 2-part lid securely. Always use the complete 2-part lid when blending (unless the tamper is inserted through the lid plug opening). Make sure that the lid is securely latched, especially when blending hot ingredients.
4. With the motor off, set the wet-blade container on the motor base by aligning it over the centring pad.

Do not attempt to put a container on an operating motor base or to operate a motor base without a container properly in place.

5. Start with the High/Variable Switch in the Variable (∟) position. Always start your machine on Variable-Speed 1. Activate the machine by turning the On/Off Switch to On (I) then slowly increase to the desired speed. Your container will shift and align itself.
6. **Take proper care when handling and processing hot ingredients and when making hot soup and sauces.**

⚠ CAUTION



To Avoid Possible Burns, Never Start on Speeds Above 1 when Processing Hot Liquids.

Escaping steam, splashes or contents may scald.

To secure the contents, lock the lid and lid plug securely in place prior to operating the machine.

Always start on Variable-Speed 1 and slowly increase to 10.



7. Due to the machine's speed, processing times are much quicker than standard appliances. Until you are accustomed to the machine, count your time carefully to avoid over-processing.
8. After turning the machine off, wait until the blades completely stop before removing the lid or container from the motor base.

OPERATING INSTRUCTIONS

Dry-Blade Container

If purchased, your dry blade container should only be used for hard, dry materials such as grain, and for kneading dough.

1. Make sure that the Variable-Speed Dial is set to 1.
2. Fasten the 2-part lid securely. Always use the complete 2-part lid when blending (unless the tamper is inserted through the lid plug opening).
3. With the motor off, set the dry-blade container on the motor base by aligning it over the centring pad. Do not attempt to put a container on an operating motor base or to operate a motor base without a container properly in place.
4. Start with the High/Variable Switch in the Variable () position. Always start your machine on Variable-Speed 1. Activate the machine by turning the On/Off Switch to On (I) then slowly increase to the desired speed. Your container will shift and align itself.
5. After turning the machine off, wait until the blades completely stop before removing the lid or container from the motor base.
6. Due to the machine's speed, and the sometimes-short processing times, count your time carefully to avoid over-processing.
7. Grinding dry material for more than two minutes could damage your machine. Regular use may result in cosmetic marring of the container and cause the blades to become dull over time.
8. Grinding some herbs may release oils, causing the container to discolour permanently. Others have strong odours that may linger in the container, affecting the flavour of other foods. The grinding of some herbs and spices may also cause the blade to dull over time, or the container to crack.

CARE AND CLEANING

Container:

To prepare your new machine for initial use, follow the steps below. This will clean the unit and break in the motor.

Normal Cleaning:

Always start the machine with the left switch down in the Variable (▲) position and with the centre Variable-Speed Dial on 1.

1. Fill the container half full of warm water and add a few drops of washing-up liquid to the container.
2. Snap or push the complete 2-Part lid into locked position.
3. Select Variable-Speed 1. Turn on the machine and slowly increase speed to Variable-Speed 10, then to High.
4. Run the machine on High Speed for 30 to 60 seconds.
5. Turn off the machine, and rinse and drain the container.

To Sanitise:

Always start the machine with the left switch down in the Variable (▲) position and with the centre Variable-Speed Dial on 1.

1. Follow the cleaning instructions above.
2. Fill the container half full of water and add 1 ½ teaspoons of liquid bleach.
3. Snap or push the complete 2-part lid into the locked position.
4. Select Variable-Speed 1. Turn on the machine and slowly increase speed to Variable-Speed 10, then to High.
5. Run the machine on High Speed for 30 to 60 seconds.
6. Allow the mixture to stand in the container for an additional 1 ½ minutes.
7. Pour out bleach mixture. Allow container to air dry.
8. Do not rinse after sanitising.

Lid, Lid Plug and Tamper

Separate the lid and lid plug. Wash parts in warm, soapy water. Rinse clean under running water and dry. Reassemble before use.

IMPORTANT: To ensure continued and effective performance, do not put the container, lid, lid plug or tamper in the dishwasher.

CARE AND CLEANING

Motor Base

1. Unplug the power cable.

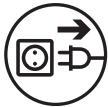
⚠ WARNING		
	<p>Electrical Shock Hazard. Unplug before cleaning machine. Failure to follow instructions can cause death or electrical shock.</p>	

2. Wash the outside surface with a damp, soft cloth or sponge that has been rinsed in a mild solution of washing-up liquid and warm water. Do not place the motor base in water.
3. The centring pad can be removed for more thorough cleaning.
4. Thoroughly clean the switches so that they work freely. They may become sticky from use. Use a moistened cotton swab to clean the grooves around the water-shielded switches. Immediately dry any excess water.
5. Polish with a soft cloth.

Recycling Information

This product has been supplied from an environmentally aware manufacturer and complies with Waste Electrical and Electronic Equipment (WEEE) Directive 2002/96/CE.

This product may contain substances that could be harmful to the environment if disposed of in places (landfills) that are not appropriate according to legislation.

The 'crossed-out wheelie bin' symbol is placed on this product to encourage you to recycle wherever possible.

Please be environmentally responsible and recycle this product through your recycling facility at the end of its life.

Used appliances may not be disposed of in the dustbin!

If the appliance has reached the end of its service life, **every user is obliged by law not to dispose of used appliances in the domestic dustbin, but rather separated from household trash**, e.g. at a community or neighbourhood collection point. This is to ensure that used appliances are professionally recycled in order to avoid damage to the environment. That is why electric appliances are marked with the 'crossed-out wheelie bin' symbol.



TROUBLESHOOTING

Your Vitamix motor is designed to be protected from overheating and overcurrent conditions during use. Both features will shut off the motor. The motor will possibly emit a slight odour. Follow the procedures below to reset the motor for either situation. If you continue to experience problems after following these instructions, contact your local distributor immediately for instructions.

Overheating Protection Resetting Procedure

If the motor shuts off due to overheating while blending, allow the machine to cool for 20-45 minutes before beginning another blending cycle. If the motor will not start after being allowed to cool, perform the Automatic Overcurrent Protection Resetting Procedure below.

Overcurrent Protection Resetting Procedure

1. Push the On/Off switch down to the Off position (O).
2. Unplug the unit.
3. Remove the container.
4. Turn the motor base on its side.
5. Press the reset button on the bottom of the machine.
6. Plug in the unit and continue with the blending cycle.

If the blender will not start immediately, the motor has overheated. Allow the motor to cool for 20-45 minutes before beginning another blending cycle.

Tips to prevent “overloading” your Vitamix machine:

- Only process Vitamix recipes when learning to use the machine
- Do not process recipes at lower speeds than recommended
- Do not process recipes at higher speeds than recommended
- Do not process recipes for longer than recommended
- Use your tamper to process thicker mixtures and keep ingredients moving around and through the blades

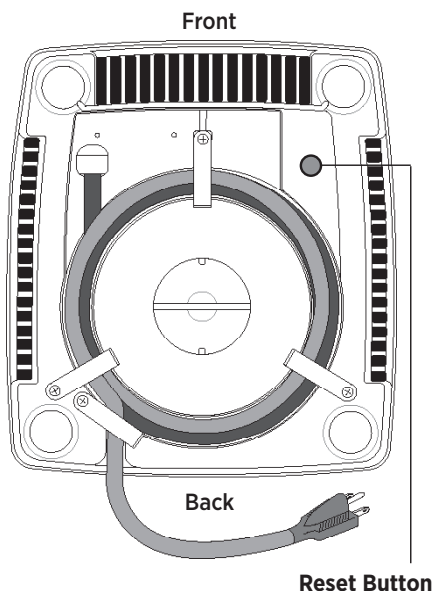

WARRANTY

Full 7-Year Machine Warranty

1. Product Registration

Vita-Mix Corporation (“Vitamix”) strongly encourages you to register your purchase. You can register by e-mailing our customer services department at service@vitamix.com or calling 0808 156 6633 (UK) or 0766 709854 (Ireland). Failure to register your product purchase will not diminish your guarantee rights. However, registering your purchase will allow Vitamix to better serve you with any of your customer service needs.

2. WHO CAN SEEK WARRANTY COVERAGE.

This Guarantee is extended by Vitamix to the owner of this machine for personal household use only. This Guarantee does not apply to products used for commercial, rental or resale purposes. Should ownership of the machine change during the 7-year period, please update the Machine’s owner information by e-mailing our customer services department at service@vitamix.com or calling 0808 156 6633 (UK) or 0766 709854 (Ireland).

3. WHAT IS COVERED.

Vitamix warrants to the owner that if this machine (a “Machine” consists of a motor blender base and any containers purchased together) fails within 7 years from the date of the initial purchase due to a defect in material or workmanship or as a result of normal wear and tear from ordinary household (domestic) use, Vitamix will, within 30 days of receipt of the returned product, repair the failed Machine or component part of the Machine free of charge. If, at Vitamix’s sole discretion, the failed Machine or component part of the Machine cannot be repaired, Vitamix will elect to either (A) replace the Machine or relevant component free of charge or (B) refund the full purchase price to the owner.

4. WHAT IS NOT COVERED.

This Guarantee does not apply to Machines that have been used commercially or in non-household (non-domestic) applications. This Guarantee does not cover cosmetic changes that do not affect performance, such as discolouration or the effects of the use of abrasives or cleaners, or food build-up. This Warranty is only valid if the Machine is used and maintained in accordance with the instructions, warnings and safeguards contained in the owner’s manual.

Vitamix will not be responsible for the cost of any unauthorised guarantee repairs.

WARRANTY

REPAIR, REPLACEMENT OR REFUND OF THE PURCHASE PRICE ARE THE EXCLUSIVE REMEDIES OF THE PURCHASER AND THE SOLE LIABILITY OF VITAMIX UNDER THIS WARRANTY. NO EMPLOYEE OR REPRESENTATIVE OF VITAMIX IS AUTHORISED TO MAKE ANY ADDITIONAL WARRANTY OR ANY MODIFICATION TO THIS WARRANTY WHICH MAY BE BINDING UPON VITAMIX. ACCORDINGLY, THE PURCHASER SHOULD NOT RELY UPON ANY ADDITIONAL STATEMENTS MADE BY ANY EMPLOYEE OR REPRESENTATIVE OF VITAMIX. IN NO EVENT, WHETHER BASED ON CONTRACT, INDEMNITY, WARRANTY, TORT (INCLUDING NEGLIGENCE), STRICT LIABILITY OR OTHERWISE, SHALL VITAMIX BE LIABLE FOR ANY SPECIAL, INDIRECT, INCIDENTAL OR CONSEQUENTIAL DAMAGES, INCLUDING, WITHOUT LIMITATION, LOSS OF PROFIT OR REVENUE.

5. WHAT VOIDS THIS WARRANTY.

Abuse, misuse, mishandling, negligent use, alteration of the Machine, exposure to abnormal or extreme conditions, usage with a voltage supply other than that specified on the Machine, or failure to follow the operating instructions will void this Guarantee. The Guarantee is also void if repairs to the Machine or any component part of the Machine are performed by someone other than either Vitamix or an authorised Vitamix Service Provider or if any component part of a Machine is used in combination with a motor-base or container or other part that is not expressly authorised by Vitamix.

6. HOW TO OBTAIN RETURNS AUTHORISATION UNDER THIS WARRANTY.

In the event that the Machine or any component part of the Machine needs service or repair, you must contact us by e-mail at service@vitamix.com or by phone at 0808 156 6633 (UK) or 0766 709854 (Ireland) to obtain a Return Authorisation number and detailed return instructions. You should then return the entire machine in the original or sufficient packaging, along with your Return Authorisation number and proof of purchase. We will then process your claim accordingly.

The purchaser is responsible for the costs of special delivery requests.

PLEASE NOTE: it is essential that the Machine be received by Vitamix no later than the last day of the Guarantee period. Late claims will not be considered.

WARRANTY

This Guarantee is honoured directly through Vita-Mix Corporation.

United States

Vita-Mix® Corporation

8615 Usher Road

Cleveland, Ohio 44138-2199

+1 440 235 4840

service@vitamix.com

United Kingdom

Vita-Mix® Corporation

c/o Sparks Transport

Wells Road

Glastonbury, Somerset BA6 9AG

0808 156 6633 (UK) or

0766 709854 (Ireland)

Any repaired or replaced Machine will be guaranteed on these terms for the unexpired portion of this Guarantee.

This Guarantee is for the benefit of you, the purchaser. No benefits may be given to any third party, except through a valid transfer by private sale to another person for domestic use of the Machine user during the period of operation of this Guarantee.

This Guarantee does not confer any rights other than those expressly set out above and does not cover any claims for consequential loss or damage.

You have statutory rights in relation to the Machine. This Guarantee is offered as an extra benefit and does not affect your statutory rights as a consumer.

Additional written copies of this Guarantee can be obtained by writing to either address listed above. Please include a stamped and self-addressed envelope for each copy of the Guarantee requested.

This Guarantee applies to Machines purchased from an authorised retailer of Vitamix within the UK and Ireland.

SPECIFICATIONS

Vitamix® Total Nutrition Center®

Motor:

≈ 2 peak horsepower motor

Electrical:

220-240 V, 50 Hz, 1100-1200 W

Dimensions:

Height: 52 cm/20.4 in.

Width: 18.5 cm/7.2 in.

Depth: 22.25 cm/8.75 in.

When applicable:



To see the complete line of Vitamix® products,
visit vitamix.com.



Vita-Mix® Corporation
8615 Usher Road
Cleveland, OH 44138-2103 U.S.A.
+1 800 848 2649 / +1 440 235 4840

vitamix.com • vitamix.co.uk • vitamix.ie

©2013 Vita-Mix® Corporation. No part of this publication may be reproduced or transmitted in any form or by any means, or stored in a database or retrieval system, without the written permission of the Vita-Mix® Corporation.