



MYX KRONOZ 

SMARTWATCH

DESIGNED IN SWITZERLAND



# ZeFit<sup>®</sup>

ENGLISH	Page 4
FRANÇAIS	Page 26
ESPAÑOL	Page 48
ITALIANO	Page 70
DEUTSCH	Page 92
NEDERLANDS	Page 114

English

ZeFit<sup>®</sup>

---

USER GUIDE

OVERVIEW	6
CHARGING	8
WEAR	10
SET UP	12
SYNC DATA	16
DISPLAY	18
ACTIVITY	20
SLEEP	21
GOALS	22
REMINDERS	23
TECH SPECS	24

## 1. OVERVIEW

---

OLED Display



Button



Charging contacts



## BOX CONTENT

ZeFit



USB Charging clip

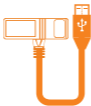

User manual





## 2. CHARGING

---

Charge ZeFit for two hours before your first use

1. Align the charging clip posts with the contacts on the back of ZeFit
2. Clip the charger securely over the face of ZeFit
3. Plug the big end of the USB Cable into the USB port of a computer
4. A battery indicator on ZeFit display will fill to indicate charging is in progress
5. Once ZeFit is charged, the battery indicator will be full

Indicator	Status
	Charging
	Charging completed
	Low battery



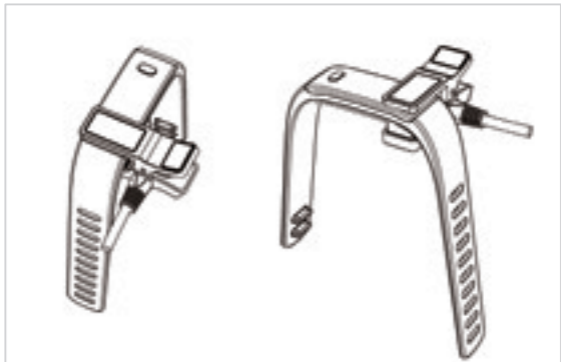

### 3. WEAR

---

ZeFit is adjustable to fit different wrist sizes.

---

1. Place ZeFit around your wrist and put the clasp over the holes
  2. Press a few times until you hear a click to make sure both ends are fully inserted and that ZeFit is securely fastened
- 



To get the most accurate data, we recommend wearing ZeFit on your non-dominant hand and not too loose



## 4. SET UP

---

The first time you use ZeFit, a display message will prompt you to set up your ZeFit through your mobile device.



### SETTING UP USING A MOBILE DEVICE

#### Mobile device Compatibility

ZeFit is compatible with Apple iOS devices and select Android devices that support Bluetooth 4.0

---

iOS 6 or later

Android 4.3

## GET ZEFIT APP

To set up your ZeFit using your mobile device, you first need to get ZeFit App. Search for “ZeFit” App on the App Store or Google Play, download and install the App on your mobile device.

Once you open ZeFit App, **Sign up** if you are a new member or **Log in** with your existing account. You will be asked to input your personal information so ZeFit can provide the most accurate results about your performance. This information remains confidential.



## BLUETOOTH PAIRING

---

1. Enable Bluetooth on your mobile device

---

2. Open ZeFit App on your mobile device. **Sign up** if you are a new member or **Log in** with your existing account

---

3. After you enter your personal information, tap **Set up your ZeFit**

---

4. Make sure ZeFit is nearby. Press ZeFit button to turn on its display. ZeFit display must be light up to initiate pairing

---

5. Your mobile device will search for ZeFit. When ZeFit is successfully paired, you will be notified on your mobile device's screen



Pairing is a one-time process. If you want to pair your mobile device with another ZeFit, you first need to unpair the current one. Go to the Settings tab of ZeFit App, unpair the current ZeFit and click on Set up to pair a new device

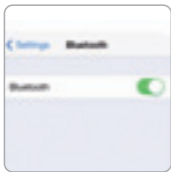

1.



3.



4.



If your mobile device cannot find ZeFit, try again and make sure (1) Bluetooth is activated on your mobile device (2) ZeFit App is running (3) ZeFit screen is light up

## 5. SYNC YOUR DATA

---

Follow these steps to manually and wirelessly sync the data stored on ZeFit to your mobile device.

---

1. Open ZeFit App
  2. On the **Activity** screen, click on the sync icon  in the upper right hand corner
  3. Press ZeFit button to light up the screen. ZeFit display must be turned on to initiate syncing
  4. A pop up window will appear on your mobile device screen to confirm successful syncing
-





2.



3.



4.

## 6. DISPLAY

---

You can view your daily activity in real time on ZeFit display with a short press of the button. Cycle through the display to browse your daily activity results.

### ACTIVITY

Current time

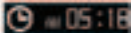

Steps taken

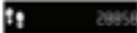

Calories burned

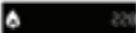

Distance travelled

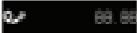

### MODE

Sleep Mode



Activity mode



## REMINDERS

Sport

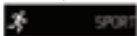

Sleep

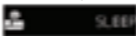

Eat



Wake up



Medicine



Defined



## OTHER DISPLAY VIEWS

Goal achieved

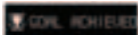

Memory Full



Syncing



*i*

ZeFit display shows daily data. The activity tracker resets at midnight

## TIME & DATE

ZeFit will automatically sync the time and date of your paired mobile device. You can set your preferred time format manually (12 or 24-hour) in the [Settings](#) tab of ZeFit App.

## 7. ACTIVITY

---

ZeFit tracks the number of steps taken, distance travelled and calories burned throughout the day. You can view your activity level and history on the [Activity](#) tab of ZeFit App. On the main [Activity](#) screen you can check your performance level against your daily goals. Click on any activity bar to get a detailed graph of your daily, weekly and monthly performance.



To upload your latest activity data, do not forget to tap the sync icon in the upper right hand corner of Zefit App and press ZeFit button to light up the screen

## 8. SLEEP

---

ZeFit tracks the hours slept and the quality of your sleep (light sleep, deep sleep, awake time).

- **Start sleep mode**

Press and hold the button until ZeFit gently vibrates and the sleep icon appears on the display



- **Exit sleep mode and switch to activity mode**

Press and hold the button until ZeFit gently vibrates and the sun icon and time appear on the display



*i*

To upload your latest sleep data, do not forget to tap the sync icon in the upper right hand corner of Zefit App and press ZeFit button to light up the screen

## 9. GOALS

---

Tap the **Goals** tab of ZeFit App to set daily goals for: steps taken, distance travelled, calories burned and hours slept.

Click on the sync button  in the upper right corner to save your goals.

Once you hit one of your daily goal, ZeFit will gently vibrate and display "Goal achieved"

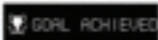

*i* You can modify your daily goals value at any time from ZeFit App.  
Do not forgot to tap the sync icon to save your new goals

## 10. REMINDERS

---

Tap the **Reminders** tab of ZeFit App to add daily life reminders. Choose your type of reminder (sport, eat, sleep, wake-up, medicine, defined), enter the preferred time and day. You can create a recurring reminder and choose which days you want the reminder to repeat. Click on **Save** to add this new reminder; it will be saved on your next sync.

ZeFit will gently vibrate and display the corresponding reminder icon to alert you. The reminder alert can be dismissed by pressing the button on ZeFit. If you do not dismiss the reminder, the same alert will repeat after two minutes.



You can set up to 6 daily reminders

## 11. TECH SPECS

---

Size & Circumference	Min: 161 mm /5.7" Max: 209 mm /8.23" Width: 20 mm /0.8"
Weight	25g
Bluetooth	4.0
Battery type	Li-ion-60mAh
Battery life	3-4 days
Charging time	2 hours
Memory	7 days of activity
Display	OLED
Sensor	3-axis accelerometer
Operating temperature	-20 to 40° C
Water resistance	Splash, sweat and rain resistant
International warranty	1 year



## ABOUT THIS MANUAL

The features of ZeFit and the contents of the user manual are subject to change. To get the latest instructions on how to use this product, please refer to the online user manual available on [www.mykronoz.com](http://www.mykronoz.com)

## SUPPORT

If you have any question or require assistance regarding our product, please visit [www.mykronoz.com/support](http://www.mykronoz.com/support) or email us at [support@mykronoz.com](mailto:support@mykronoz.com)

Français

ZeFit<sup>®</sup> 

---

GUIDE UTILISATEUR

CARACTÉRISTIQUES	28
CHARGEMENT	30
COMMENT PORTER ZEFIT	32
CONFIGURATION	34
SYNCHRONISATION DES DONNÉES	38
ÉCRAN	40
ACTIVITÉ	42
SOMMEIL	43
OBJECTIFS	44
RAPPELS	45
SPÉCIFICATIONS TECHNIQUES	46

## 1. CARACTÉRISTIQUES

---

Écran OLED

Contacts de chargement

Bouton



## CONTENU DE LA BOÎTE

ZeFit



Clip de chargement USB

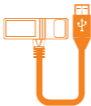

Manuel utilisateur





## 2. CHARGEMENT

---

Chargez votre ZeFit pendant deux heures avant sa première utilisation

1. Alignez les bornes du clip de chargement avec les contacts à l'arrière de votre ZeFit
2. Fixez le clip sur le cadran de votre ZeFit
3. Branchez le câble dans le port USB d'un ordinateur
4. Un indicateur de batterie sur l'écran de votre ZeFit indiquera l'évolution du niveau de charge
5. Une fois votre ZeFit chargé, l'indicateur de batterie sera plein

Indicateur	État
	Chargement en cours
	Chargement terminé
	Batterie faible

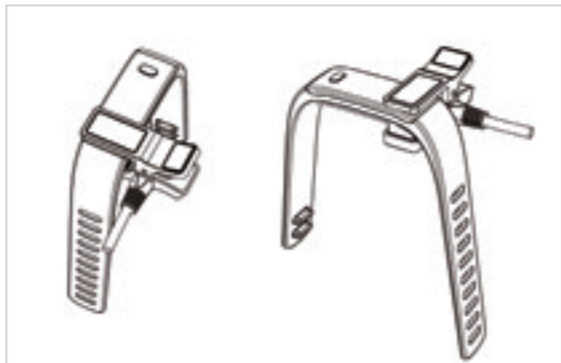

### 3. COMMENT PORTER ZEFIT

---

Votre ZeFit s'adapte à différentes tailles de poignet.

---

1. Placez votre ZeFit autour de votre poignet et insérez le fermoir dans les trous
  2. Appuyez plusieurs fois jusqu'à ce que vous entendiez un clic, pour être sûr que les deux extrémités sont entièrement insérées et que votre ZeFit est bien fixé
- 



Pour optimiser l'exactitude des données, nous vous recommandons de porter votre ZeFit à votre main non dominante, de manière assez serrée



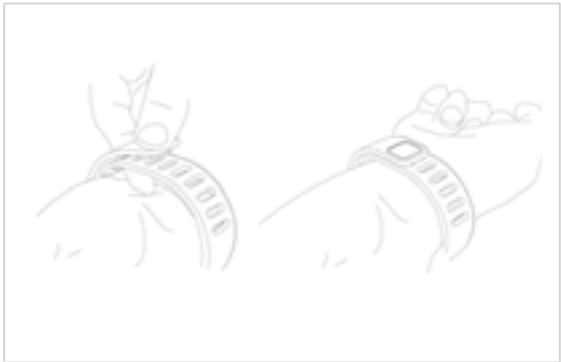

## 4. CONFIGURATION

---

Lors de la première utilisation de ZeFit, un message à l'écran vous demande de le configurer à l'aide de votre appareil mobile.



### CONFIGURATION À L'AIDE D'UN APPAREIL MOBILE

#### Compatibilité des appareils mobiles

ZeFit est compatible avec les appareils Apple iOS et certains appareils Android supportant le Bluetooth 4.0

iOS 6 ou version plus récente

Android 4.3

## TÉLÉCHARGEZ L'APPLICATION ZEFIT

Pour configurer votre ZeFit à l'aide de votre appareil mobile, vous devez préalablement télécharger l'application ZeFit.

Recherchez l'application « **ZeFit** » sur l'App Store ou Google Play, téléchargez-la et installez-la sur votre appareil mobile.

En ouvrant l'application ZeFit, allez dans **Sign up** pour créer un nouveau compte ou **Log in** pour vous connecter. Il vous sera demandé d'entrer des informations personnelles pour que ZeFit puisse vous fournir les résultats les plus précis possibles concernant votre performance. Ces informations restent confidentielles.



## COUPLAGE BLUETOOTH

---

1. Activez le Bluetooth sur votre appareil mobile
  2. Ouvrez l'application ZeFit sur votre appareil mobile. Allez dans **Sign up** pour créer un nouveau compte ou **Log in** pour vous connecter
  3. Après avoir entré vos informations personnelles, sélectionnez **Set up your ZeFit**
  4. Assurez-vous que votre ZeFit est à proximité. Appuyez sur le bouton de votre ZeFit pour allumer l'écran. L'écran de votre ZeFit doit être allumé pour débiter le couplage
  5. Votre appareil mobile effectuera alors une recherche de votre ZeFit. Lorsque le couplage est réalisé, vous recevez une notification sur l'écran de votre appareil mobile
- 



Le couplage n'est possible qu'avec un dispositif à la fois. Pour coupler votre appareil mobile avec un autre ZeFit, vous devez au préalable découpler le premier ZeFit. Accédez à l'onglet Settings dans l'application ZeFit, découpez le ZeFit et cliquez sur **Set up** pour coupler un nouveau dispositif



1.



3.



4.

*i*

Si votre appareil mobile ne parvient pas à trouver votre ZeFit, réessayez et assurez-vous que (1) le Bluetooth est activé sur votre appareil mobile, que (2) l'application ZeFit est en cours d'exécution, et que (3) l'écran de votre ZeFit est allumé

## 5. SYNCHRONISEZ VOS DONNÉES

---

Suivez ces étapes pour synchroniser manuellement et sans fil les données enregistrées sur votre ZeFit avec votre appareil mobile.

---

1. Ouvrir l'application ZeFit
  2. Sur l'écran **Activity**, cliquez sur l'icône de synchronisation  dans le coin supérieur droit
  3. Appuyez sur le bouton de votre ZeFit pour allumer l'écran. L'écran de votre ZeFit doit être activé pour débiter la synchronisation
  4. Une fenêtre contextuelle s'affichera sur l'écran de votre appareil mobile pour confirmer la réussite de la synchronisation
-



2.



3.



4.

## 6. ÉCRAN

---

Vous pouvez visualiser votre activité journalière en temps réel sur l'écran de votre ZeFit en appuyant brièvement sur le bouton. Faites défiler l'écran pour parcourir les résultats de votre activité journalière.

### ACTIVITÉ

Heure actuelle



Pas effectués

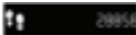

Calories brûlées



Distance parcourue



### MODE

Mode sommeil



Mode activité





## RAPPELS

Sport

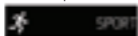

Sommeil



Repas

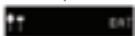

Réveil



Médicaments



Définis

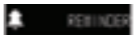

## AUTRES VUES D'ÉCRAN

Objectif atteint

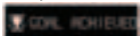

Mémoire pleine

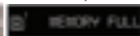

Synchronisation



*i*

L'écran ZeFit indique les données journalières. Le suiveur d'activité est réinitialisé à minuit

## HEURE & DATE

Votre ZeFit se synchronisera automatiquement avec la date et l'heure de votre appareil mobile couplé. Vous pouvez choisir manuellement votre format horaire préféré (12 ou 24 heures) dans l'onglet **Settings** de l'application ZeFit.

## 7. ACTIVITÉ

---

Votre ZeFit enregistre le nombre de pas, la distance parcourue et les calories brûlées dans la journée. Vous pouvez visualiser votre niveau d'activité et son historique dans l'onglet **Activity** de l'application ZeFit. Sur l'écran principal de la section **Activity**, vous pouvez vérifier votre niveau de performance par rapport à vos objectifs journaliers. Cliquez sur une barre d'activité pour afficher un graphique détaillé de votre performance journalière, hebdomadaire et mensuelle.



Pour télécharger vos dernières données d'activités, n'oubliez pas de toucher l'icône synchronisation dans le coin supérieur droit de l'application ZeFit et d'appuyer sur le bouton de votre ZeFit pour allumer l'écran

## 8. SOMMEIL

---

Votre ZeFit enregistre les heures et la qualité de votre sommeil (sommeil léger, sommeil profond, heure d'éveil).

- **Démarrer le mode sommeil**

Maintenez le bouton appuyé jusqu'à ce que votre ZeFit vibre légèrement et que l'icône sommeil s'affiche sur l'écran



- **Quitter le mode sommeil et basculer dans le mode activité**

Maintenez le bouton appuyé jusqu'à ce que votre ZeFit vibre légèrement et affiche l'icône soleil et l'heure à l'écran

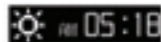

*i*

Pour télécharger vos dernières données sur le sommeil, n'oubliez pas de toucher l'icône synchronisation dans le coin supérieur droit de l'application ZeFit et d'appuyer sur le bouton de votre ZeFit pour allumer l'écran

## 9. OBJECTIFS

---

Sélectionnez l'onglet **Goals** de l'application ZeFit pour définir les objectifs journaliers : nombre de pas, distance parcourue, calories brûlées et durée du sommeil.

Cliquez sur le bouton synchronisation  dans le coin supérieur droit pour sauvegarder vos objectifs.

Lorsque vous atteignez l'un de vos objectifs journaliers, votre ZeFit vibrera légèrement et affichera « Goal achieved »



*i*

Vous pouvez à tout moment modifier vos objectifs journaliers à partir de l'application ZeFit. N'oubliez pas d'appuyer sur l'icône de synchronisation pour sauvegarder vos nouveaux objectifs

## 10. RAPPELS

---

Sélectionnez l'onglet **Reminders** de l'application ZeFit pour ajouter vos rappels journaliers. Choisissez votre type de rappel (sport, repas, sommeil, réveil, médicament, défini), entrez l'heure et le jour préférés. Vous pouvez créer un rappel récurrent et choisir les jours de rappel. Cliquez sur **Save** pour ajouter ce nouveau rappel ; il sera sauvegardé lors de votre prochaine synchronisation.

Votre ZeFit vibrera légèrement et affichera l'icône de rappel correspondante pour vous alerter. L'alarme de rappel peut être désactivée en appuyant sur le bouton de votre ZeFit. Si vous ne désactivez pas le rappel, l'alarme se répétera après deux minutes.



Vous pouvez définir jusqu'à 6 rappels quotidiens

## 11. SPÉCIFICATIONS TECHNIQUES

---

Taille & circonférence	Min : 161 mm /5.7" Max : 209 mm /8.23" Largeur : 20 mm /0.8"
Poids	25 grs
Bluetooth	4.0
Type de batterie	Li-ion-60mAh
Autonomie de la batterie	3-4 jours
Temps de charge	2 heures
Mémoire	7 jours d'activité
Écran	OLED
Capteur	Accéléromètre triaxial
Température de fonctionnement	-20°C à +40°C
Résistance à l'eau	Résiste aux éclaboussures, à la transpiration et à la pluie
Garantie internationale	1 an

## À PROPOS DE CE MANUEL

Les caractéristiques de l'appareil et le contenu du manuel d'utilisateur sont susceptibles d'être modifiés. Pour obtenir les dernières instructions sur l'utilisation de ce produit, veuillez vous référer au manuel de l'utilisateur disponible sur [www.mykronoz.com](http://www.mykronoz.com)

## ASSISTANCE

En cas de questions ou de demande d'assistance concernant le produit, veuillez consulter [www.mykronoz.com/support](http://www.mykronoz.com/support) ou nous envoyer un e-mail à [support@mykronoz.com](mailto:support@mykronoz.com)

Español

ZeFit<sup>®</sup>

---

GUÍA DEL USUARIO



GENERALIDADES	50
CARGA	52
LLEVAR PUESTA	54
CONFIGURAR	56
SINCRONIZAR DATOS	60
PANTALLA	62
ACTIVIDAD	64
SUEÑO	65
OBJETIVOS	66
AVISOS	67
ESPEC. TÉCNICAS	68

## 1. GENERALIDADES

---

Pantalla OLED



Botón



Contactos de carga



## CONTENIDO DE LA CAJA

ZeFit



Clip de carga USB

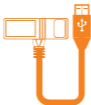

Manual del usuario



## 2. CARGA

---

Cargue ZeFit durante dos horas antes de usarlo por primera vez

1. Alinee los toques del clip de carga con los contactos de la parte posterior de ZeFit
2. Enganche con el clip el cargador firmemente sobre el anverso de ZeFit
3. Conecte el extremo grande del cable USB en el puerto USB del ordenador
4. Un indicador de batería en la pantalla de ZeFit se rellenará para indicar que la carga está en curso
5. Una vez que ZeFit se ha cargado, el indicador de batería se mostrará lleno

Indicador	Estado
	Carga
	Carga finalizada
	Capacidad baja de la batería

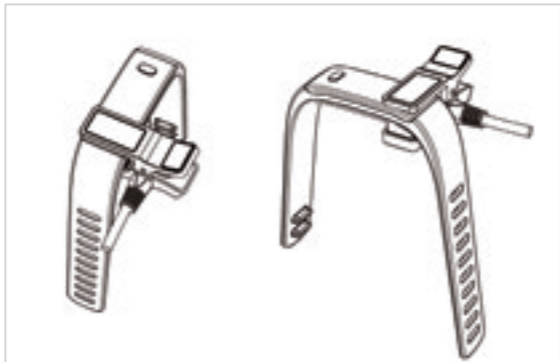

### 3. LLEVAR PUESTA

---

ZeFit se puede ajustar para adaptarse a diferentes tamaños de muñeca.

---

1. Coloque ZeFit alrededor de su muñeca y ponga el cierre sobre los agujeros
  2. Presione varias veces hasta que oiga un clic para asegurarse de que ambos extremos se han insertado totalmente y que ZeFit está bien abrochada
- 



Para obtener los datos más precisos, recomendamos que lleve puesta ZeFit en su mano no dominante y no demasiado suelta

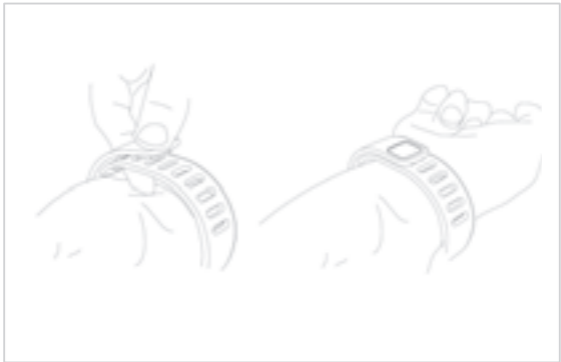

## 4. CONFIGURAR

---

La primera vez que utiliza ZeFit, un mensaje le indicará que configure su ZeFit a través de su dispositivo móvil.



SET UP

### CONFIGURACIÓN CON UN DISPOSITIVO MÓVIL

#### Compatibilidad con dispositivos móviles

ZeFit es compatible con dispositivos Apple iOS y dispositivos Android seleccionados que admitan Bluetooth 4.0

iOS 6 o posterior

Android 4.3



## CONSEGUIR LA APLICACIÓN ZEFIT

Para configurar su ZeFit con su dispositivo móvil, primero tiene que conseguir la aplicación ZeFit.

Busque la aplicación "ZeFit" en la App Store o Google Play, descárguela e instálela en su dispositivo móvil.

Una vez abierta la aplicación ZeFit, **Sign up** si es un nuevo miembro o **Log in** con su cuenta existente. Se le indicará que introduzca su información personal para que ZeFit pueda proporcionar los resultados más precisos sobre su rendimiento. Esta información tiene carácter confidencial.



## EMPAREJAMIENTO BLUETOOTH

---

1. Active Bluetooth en su dispositivo móvil
2. Abra la aplicación ZeFit en su dispositivo móvil. **Sign up** si es un nuevo miembro o **Log in** con su cuenta existente
3. Una vez que haya introducido su información personal, puntee en **Set up your ZeFit**
4. Asegúrese de que ZeFit esté cerca. Pulse el botón ZeFit para encender la pantalla. La pantalla de ZeFit debe estar encendida para iniciar el emparejamiento
5. Su dispositivo móvil buscará a ZeFit. Cuando ZeFit esté emparejado correctamente, se le notificará en la pantalla de su dispositivo móvil



El emparejamiento es un proceso de una sola vez. Si quiere emparejar su dispositivo móvil con otro ZeFit, antes tiene que desemparejar el actual. Vaya a la ficha Settings de la aplicación ZeFit, desempareje el ZeFit actual y haga clic en Set up para emparejar un nuevo dispositivo



1.



3.



4.

*i*

Si su dispositivo móvil no puede encontrar a ZeFit, pruebe de nuevo y asegúrese de que (1) Bluetooth está activado en su dispositivo móvil (2) la aplicación ZeFit se está ejecutando (3) la pantalla de ZeFit está encendida

## 5. SINCRONIZAR SUS DATOS

---

Siga estos pasos para sincronizar manualmente y de forma inalámbrica los datos almacenados en ZeFit con su dispositivo móvil.

---

1. Abra la aplicación Zefit
  2. En la pantalla **Activity**, haga clic en el icono de sincronización  de la esquina superior derecha
  3. Pulse el botón ZeFit para encender la pantalla. La pantalla de ZeFit debe estar encendida para iniciar la sincronización
  4. Aparecerá una ventana emergente en la pantalla de su dispositivo móvil para confirmar que la sincronización se ha realizado correctamente
-



2.



3.



4.

## 6. PANTALLA

---

Puede ver su actividad diaria en tiempo real en la pantalla de ZeFit con una breve pulsación del botón. Desplácese por la pantalla para examinar sus resultados de actividad diarios.

### ACTIVIDAD

Hora actual



Pasos dados

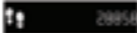

Calorías consumidas

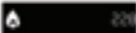

Distancia recorrida

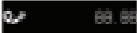

### MODOS

Modo Sueño



Modo Actividad



## AVISOS

Deporte

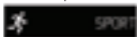

Dormir



Comer



Despertarse

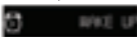

Medicina



Definido



## OTRAS VISTAS DE LA PANTALLA

Objetivo logrado



Memoria llena



Sincronización



*i*

La pantalla de ZeFit muestra los datos diarios. El seguidor de actividad se reinicializa a medianoche

## HORA Y FECHA

ZeFit sincronizará automáticamente la hora y la fecha de su dispositivo móvil emparejado. Puede configurar manualmente su formato de hora preferido (12 o 24 horas) en la ficha **Settings** de la aplicación ZeFit.

## 7. ACTIVIDAD

---

ZeFit monitoriza el número de pasos dados, la distancia recorrida y las calorías consumidas a lo largo del día. Puede ver su nivel e historial de actividad en la ficha **Activity** de la aplicación ZeFit. En la pantalla **Activity** principal, puede consultar su nivel de rendimiento frente a sus objetivos diarios. Haga clic en cualquier barra de actividad para obtener una gráfica detallada de su rendimiento diario, semanal y mensual.



Para cargar sus últimos datos de actividad, no olvide puntear en el icono de sincronización de la esquina superior derecha de la aplicación Zefit y pulsar el botón ZeFit para encender la pantalla



## 8. SUEÑO

---

ZeFit monitoriza las horas que duerme y la calidad de su sueño (sueño ligero, sueño profundo, tiempo despierto).

- **Iniciar el modo sueño**

Mantenga pulsado el botón hasta que ZeFit vibre suavemente y aparezca el icono de dormir en la pantalla



- **Salir del modo sueño y cambiar al modo actividad**

Mantenga pulsado el botón hasta que ZeFit vibre suavemente y aparezcan el icono del sol y la hora en la pantalla



*i*

Para cargar sus últimos datos de sueño, no olvide puntear en el icono de sincronización de la esquina superior derecha de la aplicación Zefit y pulsar el botón ZeFit para encender la pantalla

## 9. OBJETIVOS

---

Puntee en la ficha **Goals** de la aplicación ZeFit para establecer sus objetivos diarios de: pasos dados, distancia recorrida, calorías consumidas y horas de sueño.

Haga clic en el botón de sincronización  de la esquina superior derecha para guardar sus objetivos.

Cuando logre uno de sus objetivos diarios, ZeFit vibrará suavemente y mostrará el mensaje "Goal achieved"



*i*

Puede modificar sus objetivos diarios en cualquier momento desde la aplicación Zefit. No olvide puntear en el icono de sincronización para guardar sus nuevos objetivos

## 10. AVISOS

---

Puntee en la ficha **Reminders** de la aplicación ZeFit para añadir avisos de la vida diaria. Elija su tipo de aviso (deporte, comer, dormir, despertarse, medicina, definido), introduzca la hora y fecha que desea. Puede crear un aviso recurrente y elegir los días que quiere que se repita. Haga clic en **Save** para añadir este nuevo aviso; se guardará en su próxima sincronización.

ZeFit vibrará suavemente y mostrará el icono de aviso para alertarle. La alerta de aviso se puede rechazar pulsando el botón de ZeFit. Si no rechaza el aviso, se repetirá la misma alerta después de dos minutos.



Puede configurar un máximo de 6 avisos diarios

## 11. ESPEC. TÉCNICAS

---

Tamaño y circunferencia	Mín.: 161 mm/5,7" Máx.: 209 mm/8,23" Ancho: 20 mm/0,8"
Peso	25 g
Bluetooth	4.0
Tipo de batería	Iones de litio, 60 mAh
Vida de la batería	3 a 4 días
Tiempo de carga	2 horas
Memoria	7 días de actividad
Pantalla	OLED
Sensor	Acelerómetro de 3 ejes
Temperatura de funcionamiento	-20 °C a +40 °C
Resistencia al agua	Resistente a las salpicaduras, al sudor y a la lluvia
Garantía internacional	1 año

## ACERCA DE ESTE MANUAL

Las características de ZeFit y el contenido del manual del usuario pueden ser modificados. Para obtener las últimas instrucciones sobre cómo usar este producto, consulte el manual del usuario en línea disponible en [www.mykronoz.com](http://www.mykronoz.com)

## SOPORTE

Si tiene alguna pregunta o necesita asistencia en relación con nuestro producto, visite [www.mykronoz.com/support](http://www.mykronoz.com/support) o envíenos un correo electrónico a [support@mykronoz.com](mailto:support@mykronoz.com)

Italiano

ZeFit<sup>®</sup> 

---

ISTRUZIONI PER L'USO

INFORMAZIONI GENERALI	72
CARICA	74
UTILIZZO	76
CONFIGURAZIONE	78
SINCRONIZZAZIONE DEI DATI	82
DISPLAY	84
ATTIVITÀ	86
SONNO	87
OBIETTIVI	88
PROMEMORIA	89
SPECIFICHE TECNICHE	90

## 1. INFORMAZIONI GENERALI

---

Display OLED

Contatti di carica

Tasto





## CONTENUTO DELLA CONFEZIONE

ZeFit



Clip di carica USB



Manuale di istruzioni



## 2. CARICA

---

Lasciare lo ZeFit in carica due ore prima del primo utilizzo.

1. Allineare i contatti della clip di carica con i contatti posti sul retro dello ZeFit.
2. Agganciare il caricatore sul lato anteriore dello ZeFit.
3. Collegare il connettore all'estremità del cavo alla porta USB di un PC.
4. Un indicatore sul display dello ZeFit segnalerà l'avanzamento della carica.
5. Al termine della carica l'indicatore sarà pieno.

Indicatore	Stato
	Carica
	Carica completa
	Livello batteria basso

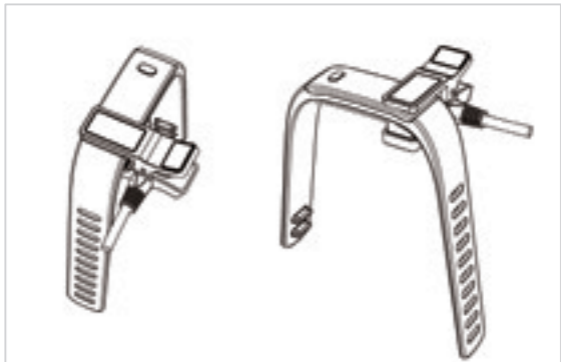

### 3. UTILIZZO

---

ZeFit è regolabile in base alla misura del polso.

---

1. Indossare lo ZeFit al polso e posizionare le alette sporgenti in corrispondenza dei fori.
  2. Premere fino a udire un clic, così da inserire entrambe le alette e agganciare correttamente lo ZeFit.
- 

*i*

Per ottenere risultati di precisione, si raccomanda di indossare lo ZeFit sulla mano non dominante e di stringere il bracciale adeguatamente.

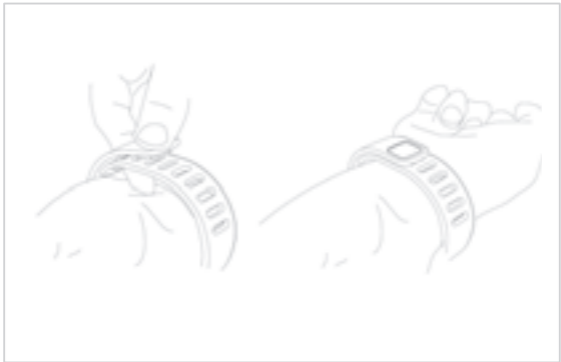

## 4. CONFIGURAZIONE

---

Al primo utilizzo di ZeFit, un messaggio sul display chiederà di configurare lo ZeFit tramite dispositivo mobile.



### CONFIGURAZIONE TRAMITE DISPOSITIVO MOBILE

#### Compatibilità con i dispositivi mobili

ZeFit è compatibile con dispositivi Apple iOS e con alcuni dispositivi Android che supportano la tecnologia Bluetooth 4.0.

iOS 6 o successivi

Android 4.3

## SCARICARE L'APP ZEFIT

Per configurare lo ZeFit tramite dispositivo mobile, occorre prima scaricare l'app ZeFit.

Cercare l'app "**ZeFit**" su App Store o Google Play, scaricarla e installarla sul dispositivo mobile.

Una volta aperta l'app ZeFit, occorre selezionare **Sign up** (nuovi utenti) oppure **Log in** per entrare nell'account esistente. Verrà richiesto di inserire alcune informazioni personali, in modo da garantire risultati precisi sulle prestazioni. Le informazioni fornite rimarranno riservate.



## ASSOCIAZIONE TRAMITE BLUETOOTH

---

1. Attivare il Bluetooth sul dispositivo mobile

---

2. Aprire l'app ZeFit sul dispositivo mobile. Selezionare **Sign up** (per i nuovi utenti) oppure **Log in** per entrare nell'account esistente.

---

3. Una volta inserite le informazioni personali, selezionare **Set up your ZeFit**.

---

4. Accertarsi che lo ZeFit si trovi nelle vicinanze. Premere il tasto dello ZeFit per accendere il display. Per iniziare l'associazione, il display deve essere acceso.

---

5. Il dispositivo mobile cerca lo ZeFit. Una volta effettuata l'associazione verrà visualizzato un messaggio sullo schermo del dispositivo mobile.



L'associazione va eseguita una volta sola. Per associare il dispositivo mobile a un altro ZeFit, occorre prima rimuovere quello corrente. Aprire la scheda Impostazioni sull'app ZeFit, rimuovere lo ZeFit corrente e fare clic su Configura per associare un nuovo dispositivo.





1.



3.



4.

*i*

Se il dispositivo mobile non riesce a trovare lo ZeFit, riprovare verificando (1) che il Bluetooth sia attivato sul dispositivo mobile, (2) che l'app ZeFit sia in esecuzione e (3) che il display dello ZeFit sia acceso.

## 5. SINCRONIZZAZIONE DEI DATI

---

Questa procedura permette di sincronizzare manualmente e in modalità wireless i dati memorizzati nello ZeFit sul dispositivo mobile.

---

1. Aprire l'app ZeFit.
  2. Dalla schermata **Activity**, fare clic sull'icona di sincronizzazione  nell'angolo superiore destro.
  3. Premere il tasto dello ZeFit per accendere il display. Il display dello ZeFit deve essere acceso per poter avviare la sincronizzazione.
  4. Sul dispositivo mobile comparirà una finestra a conferma dell'avvenuta sincronizzazione.
-



2.



3.



4.

## 6. DISPLAY

---

È possibile visualizzare l'attività giornaliera in tempo reale sul display ZeFit premendo il tasto brevemente. Navigare nel display per visualizzare i risultati delle attività quotidiane.

### ATTIVITÀ

Ora attuale

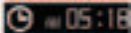

Numero di passi

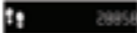

Calorie bruciate

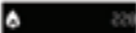

Distanza percorsa

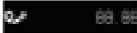

### MODALITÀ

Modalità Sonno



Modalità Attività



## PROMEMORIA

Sport

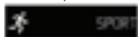

Sonno



Pasto



Sveglia



Medicina



Generico

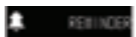

## ALTRI DATI VISUALIZZATI SUL DISPLAY

Obiettivo raggiunto



Memoria piena

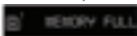

Sincronizzazione in corso



*i*

Il display dello ZeFit mostra i dati quotidiani. Il tracciamento delle attività viene azzerato a mezzanotte.

## DATA E ORA

ZeFit sincronizza automaticamente la data e l'ora con il dispositivo mobile associato. È possibile impostare il formato dell'ora manualmente (12 o 24 ore) dalla scheda **Settings** dell'app ZeFit.

## 7. ATTIVITÀ

---

ZeFit rileva il numero di passi, la distanza percorsa e le calorie bruciate durante la giornata. È possibile visualizzare il livello di attività e la cronologia sulla scheda **Activity** dell'app ZeFit. Sulla schermata principale della scheda **Activity** è possibile confrontare il livello di prestazioni con gli obiettivi giornalieri. Fare clic sulla barra delle attività per visualizzare un grafico dettagliato delle prestazioni giornaliere, settimanali e mensili.



*i*

Per caricare i dati recenti relativi alle attività, non dimenticare di selezionare l'icona di sincronizzazione nell'angolo superiore destro dell'app ZeFit e di premere il tasto dello ZeFit per accendere il display.

## 8. SONNO

---

ZeFit tiene traccia delle ore dormite e della qualità del sonno (leggero, profondo, ora del risveglio).

- **Attivare la modalità Sonno**

Premere e tenere premuto il tasto fino a percepire una leggera vibrazione. Sul display verrà visualizzata l'icona Sonno.



- **Uscire dalla modalità Sonno e passare alla modalità Attività**

Premere e tenere premuto il tasto fino a percepire una leggera vibrazione. Sul display verranno visualizzate l'icona con il sole e l'ora.



*i*

Per caricare i dati recenti relativi al sonno, non dimenticare di selezionare l'icona di sincronizzazione nell'angolo superiore destro dell'app ZeFit e di premere il tasto dello ZeFit per accendere il display.

## 9. OBIETTIVI

---

Selezionare la scheda **Goals** dell'app ZeFit per impostare gli obiettivi giornalieri come: numero di passi, distanza percorsa, calorie bruciate e ore di sonno.

Selezionare il tasto di sincronizzazione  nell'angolo superiore destro per salvare gli obiettivi.

Al raggiungimento di uno degli obiettivi giornalieri, ZeFit emetterà una leggera vibrazione e visualizzerà la scritta "Goal achieved".



*i*

È possibile modificare il valore degli obiettivi giornalieri in qualsiasi momento tramite l'app ZeFit. Non dimenticare di selezionare l'icona di sincronizzazione per salvare i nuovi obiettivi.



## 10. PROMEMORIA

---

Selezionare la scheda **Reminders** sull'app ZeFit per aggiungere promemoria giornalieri. Scegliere il tipo di promemoria (sport, pasto, sonno, sveglia, medicina, generico) e inserire data e ora. È possibile creare un promemoria ricorrente e scegliere i giorni in cui attivarlo. Fare clic su **Save** per aggiungere il nuovo promemoria, che verrà salvato durante la sincronizzazione successiva.

ZeFit emette una leggera vibrazione e visualizza l'icona del promemoria corrispondente. L'allarme può essere disattivato premendo il tasto dello ZeFit. In caso contrario il promemoria verrà riproposto dopo due minuti.



È possibile impostare un massimo di 6 promemoria giornalieri.

## 11. SPECIFICHE TECNICHE

---

Dimensioni e circonferenza	Min: 161 mm Max: 209 mm Larghezza: 20 mm
Peso	25 g
Bluetooth	4.0
Tipo di batteria	Ioni di litio, 60 mAh
Autonomia batteria	3-4 giorni
Tempo di carica	2 ore
Memoria	7 giorni di attività
Display	OLED
Sensore	Accelerometro a 3 assi
Temperatura di esercizio	-20°C a +40°C
Resistenza all'acqua	Resistente a spruzzi, sudore e pioggia
Garanzia internazionale	1 anno

## INFORMAZIONI SUL MANUALE

Le funzionalità dello ZeFit e i contenuti del manuale di istruzioni sono soggetti a modifiche. Per ottenere le istruzioni più aggiornate sull'uso del prodotto, consultare il manuale online disponibile su [www.mykronoz.com](http://www.mykronoz.com).

## ASSISTENZA

Per domande o richieste di assistenza relative al prodotto, visitare [www.mykronoz.com/support](http://www.mykronoz.com/support) o inviare un'e-mail all'indirizzo [support@mykronoz.com](mailto:support@mykronoz.com).

Deutsch

ZeFit<sup>®</sup> 

---

BENUTZERHANDBUCH

ÜBERSICHT	94
LADEN	96
GEBRAUCHSEIGENSCHAFTEN	98
EINSTELLUNG	100
DATEN SYNCHRONISIEREN	104
DISPLAY	106
AKTIVITÄT	108
SCHLAFEN	109
ZIELE	110
ERINNERUNGEN	111
TECH. SPEZ.	112

# 1. ÜBERSICHT

---

OLED-Display

Ladekontakte

Taste



## INHALT DES KARTONS

ZeFit



USB-Ladeklemme

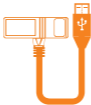

Benutzerhandbuch





## 2. LADEVORGANG

---

Laden Sie ZeFit vor dem ersten Gebrauch zwei Stunden auf

1. Setzen Sie die Elektroden des Ladegeräts in die Kontakte auf der Rückseite von ZeFit ein
2. Klemmen Sie das Ladegerät sicher über die Vorderseite von ZeFit
3. Stecken Sie das große Ende des USB-Kabels in den USB-Anschluss eines Computers
4. Eine Batterieanzeige auf dem ZeFit-Display wird aufgefüllt, um das Aufladen anzuzeigen
5. Sobald ZeFit aufgeladen ist, ist die Batterieanzeige voll

Anzeige	Status
	Aufladen
	Aufladen beendet
	Batterie niedrig



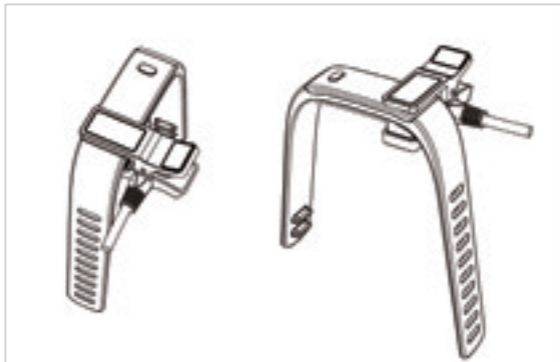

### 3. GEBRAUCHSEIGENSCHAFTEN

---

ZeFit kann für verschiedene Handgelenkgrößen angepasst werden.

---

1. Legen Sie ZeFit um Ihr Handgelenk und legen Sie den Verschluss über die Löcher
  2. Drücken Sie einige Male, bis dass Sie einen Klick hören, um sicher zu stellen, dass beide Enden ganz eingefügt sind und dass ZeFit sicher befestigt ist
- 

*i*

Um die genauesten Daten zu erreichen, empfehlen wir, ZeFit an Ihrer nicht-dominanten Hand und nicht zu locker zu tragen

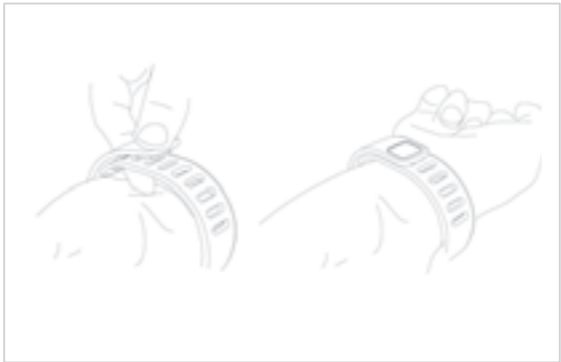

## 4. EINSTELLUNG

---

Wenn Sie ZeFit zum ersten Mal benutzen, werden Sie durch eine Display-Nachricht aufgefordert, Ihr ZeFit über Ihr Mobilgerät einzustellen.



### EINSTELLUNG MIT HILFE EINES MOBILGERÄTS

#### Kompatibilität des Mobilgeräts

ZeFit ist kompatibel mit Apple iOS-Geräten und ausgewählten Android Geräten, die Bluetooth 4.0 unterstützen

iOS 6 oder später

Android 4.3

## ZEFIT-APP ERHALTEN

Wenn Sie Ihr ZeFit mit Hilfe Ihres Mobilgeräts einstellen möchten, benötigen Sie als erstes die ZeFit-App.

Suchen Sie "ZeFit"-App im App Store oder in Google Play, laden Sie sie herunter und installieren Sie die App auf Ihrem Mobilgerät.

Wenn Sie die ZeFit-App öffnen, **Sign up**, wenn Sie ein neues Mitglied sind, oder **Log in** mit Ihrem bestehenden Konto. Sie werden gebeten, Ihre persönlichen Daten einzugeben, so dass ZeFit die genauesten Ergebnisse in Bezug auf Ihre Leistung liefern kann. Diese Angaben bleiben vertraulich.



## BLUETOOTH-PAIRING

---

1. Aktivieren Sie Bluetooth auf Ihrem Mobilgerät

---

2. Öffnen Sie die ZeFit-App auf Ihrem Mobilgerät. **Sign up**, wenn Sie ein neues Mitglied sind oder **Log in** mit Ihrem bestehenden Konto

---

3. Nachdem Sie Ihre persönlichen Daten eingegeben haben, tippen Sie auf **Set up your ZeFit**

---

4. Vergewissern Sie sich, dass ZeFit in der Nähe ist. Drücken Sie auf die ZeFit-Taste, um das Display anzuschalten. Das ZeFit-Display muss angeschaltet sein, um das Pairing zu initiieren

---

5. Ihr Mobilgerät wird ZeFit suchen. Wenn ZeFit erfolgreich gepairt ist, werden Sie auf dem Bildschirm Ihres Mobilgeräts benachrichtigt



Pairing ist ein einmaliger Prozess. Wenn Sie Ihr Mobilgerät mit einem anderen ZeFit pairen möchten, müssen Sie zunächst das aktuelle entpairen. Begeben Sie sich in den Reiter "Einstellungen" der ZeFit-App, entpairen Sie das aktuelle ZeFit und klicken Sie auf Einstellungen, um ein neues Gerät zu pairen



1.



3.



4.

*i*

Falls Ihr Mobilgerät ZeFit nicht finden kann, versuchen Sie es noch einmal und vergewissern Sie sich, dass (1) Bluetooth auf Ihrem Mobilgerät aktiviert ist, (2) die ZeFit-App aktiviert ist, (3) der ZeFit-Bildschirm angeschaltet ist

## 5. SYNCHRONISIEREN SIE IHRE DATEN

---

Befolgen Sie diese Schritte, um die Daten, die auf ZeFit gespeichert sind, manuell und drahtlos mit Ihrem Mobilgerät zu synchronisieren.

---

1. Öffnen Sie die ZeFit-App
  2. Klicken Sie im Bildschirm **Activity** auf das Synchronisieren-Symbol  oben in der rechten Ecke
  3. Drücken Sie auf die ZeFit-Taste, um den Bildschirm anzuschalten. Das ZeFit-Display muss auf Synchronisierung initiieren gestellt werden
  4. Ein Pop-up-Fenster erscheint auf Ihrem Mobilgerät, um die erfolgreiche Synchronisierung zu bestätigen
-





2.

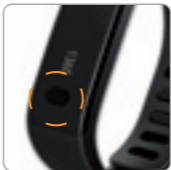

3.



4.

## 6. DISPLAY

---

Sie können sich Ihre tägliche Aktivität in Echtzeit auf dem ZeFit-Display anschauen, indem Sie kurz auf die Taste drücken. Gehen Sie durch das Display, um die Ergebnisse Ihrer täglichen Aktivitäten zu durchstöbern.

### AKTIVITÄT

Aktuelle Uhrzeit



Gemachte Schritte



Verbrannte Kalorien



Zurückgelegte Distanz

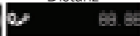

### MODUS

Schlafmodus



Aktivitäten-Modus



## ERINNERUNGEN

Sport

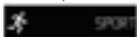

Schlafen



Essen



Aufwachen



Medizin



Definiert



## ANDERE DISPLAY-ANSICHTEN

Ziel erreicht

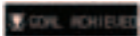

Speicher voll



Synchronisierung



*i*

Das ZeFit-Display zeigt tägliche Daten. Der Aktivitäten-Tracker wird um Mitternacht zurückgestellt

## ZEIT und DATUM

ZeFit synchronisiert automatisch die Zeit und das Datum Ihres gepairten Mobilgeräts. Sie können Ihr bevorzugtes Zeitformat (12 oder 24-Stunden) manuell im Reiter **Settings** der ZeFit-App einstellen.

## 7. AKTIVITÄT

---

ZeFit registriert die Anzahl der gemachten Schritte, die im Laufe des Tages zurückgelegte Distanz und die verbrannten Kalorien. Sie können sich Ihr Aktivitätsniveau und die Entwicklung im Reiter **Activity** in der ZeFit-App ansehen. Sie können im Hauptbildschirm **Activity** Ihr Leistungsniveau im Vergleich zu Ihren täglichen Zielen überprüfen. Klicken Sie auf eine Aktivitätenleiste für eine detaillierte grafische Darstellung Ihrer täglichen, wöchentlichen und monatlichen Leistung.



Um Ihre letzten Aktivitätsdaten hochzuladen, vergessen Sie nicht, auf das Synchronisieren-Symbol oben in der rechten Ecke von ZeFit-App zu tippen und die ZeFit-Taste zu drücken, um den Bildschirm anzuschalten

## 8. SCHLAFEN

---

ZeFit registriert die geschlafenen Stunden und die Qualität Ihres Schlafs (leichter Schlaf, tiefer Schlaf, wache Zeit).

- **Starten Sie den Schlafmodus**

Halten Sie die Taste gedrückt, bis dass ZeFit leicht vibriert und das Schlaf-Symbol auf dem Display erscheint



- **Gehen Sie aus dem Schlafmodus heraus und schalten Sie in den Aktivitäten-Modus**

Halten Sie die Taste gedrückt, bis dass ZeFit leicht vibriert und das Sonnensymbol sowie die Zeit auf dem Display erscheint

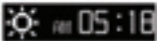

*i*

Um Ihre letzten Schlafdaten hochzuladen, vergessen Sie nicht, auf das Synchronisieren-Symbol oben in der rechten Ecke der Zefit-App zu tippen und die ZeFit-Taste zu drücken, um den Bildschirm anzuschalten

## 9. ZIELE

---

Tippen Sie auf den Reiter **Goals** der ZeFit-App, um tägliche Ziele für Folgendes einzustellen: gemachte Schritte, zurückgelegte Distanz, verbrannte Kalorien und geschlafene Stunden.

Klicken Sie auf die Taste Synchronisieren  oben in der rechten Ecke, um Ihre Ziele zu speichern.

Sobald Sie Ihr Tagesziel erreicht haben, vibriert ZeFit leicht und zeigt "Goal achieved" an

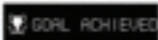

Sie können Ihre Tagesziele jederzeit von der ZeFit-App aus abändern. Vergessen Sie nicht, auf das Synchronisieren-Symbol zu tippen, um Ihre neuen Ziele zu speichern

## 10. ERINNERUNGEN

---

Tippen Sie auf den Reiter **Reminders** der ZeFit-App, um Erinnerungen für das tägliche Leben hinzuzufügen. Wählen Sie die Art der Erinnerung (Sport, Essen, Schlafen, Aufwachen, Medizin, Definiert) aus, geben Sie die bevorzugte Zeit und den bevorzugten Tag ein. Sie können eine wiederkehrende Erinnerung erstellen und auswählen, an welchen Tagen die Erinnerung wiederholt werden soll. Klicken Sie auf **Save**, um diese neue Erinnerung hinzuzufügen, sie wird bei Ihrer nächsten Synchronisierung gespeichert.

ZeFit vibriert leicht und zeigt das entsprechende Erinnerungs-Symbol an, um Sie zu benachrichtigen. Der Erinnerungsalarm kann abgestellt werden, indem man auf die Taste auf ZeFit drückt. Falls Sie die Erinnerung nicht abstellen, wird derselbe Alarm nach zwei Minuten wiederholt.



Sie können bis zu 6 tägliche Erinnerungen einstellen

## 11. TECH. SPEZ.

---

Größe und Umfang	Mini.: 161 mm /5.7" Maxi.: 209 mm /8.23" Breite: 20 mm /0.8"
Gewicht	25 g
Bluetooth	4.0
Batterietyp	Li-ion-60mAh
Batterieleben	3-4 Tage
Ladezeit	2 Stunden
Speicher	7 Tage Aktivität
Display	OLED
Sensor	Dreiachsiger Beschleunigungsmesser
Betriebstemperatur	-20°C bis +40°C
Wasserdichtigkeit	Schutz vor Spritzer, Schweiß und Regen
Internationale Garantie	1 Jahr



## ÜBER DIESES HANDBUCH

Die Merkmale der ZeFit und der Inhalt des Benutzerhandbuchs können abgeändert werden. Schauen Sie bitte für die aktuellsten Anweisungen in Bezug auf die Nutzung dieses Produkts im Online-Benutzerhandbuch nach, das auf [www.mykronoz.com](http://www.mykronoz.com) zur Verfügung steht.

## HILFE

Falls Sie Fragen haben oder Hilfe in Bezug auf unser Produkt benötigen, begeben Sie sich bitte auf [www.mykronoz.com/support](http://www.mykronoz.com/support) oder schicken Sie uns eine E-Mail an [support@mykronoz.com](mailto:support@mykronoz.com)

Nederlands

ZeFit<sup>®</sup>

---

HANDLEIDING

OVERZICHT	116
OPLADEN	118
DRAGEN	120
INSTELLEN	122
GEGEVENS SYNCHRONISEREN	126
SCHERM	128
ACTIVITEIT	130
SLAAP	131
DOELSTELLINGEN	132
HERINNERINGEN	133
TECHNISCHE SPECIFICATIES	134

## 1. OVERZICHT

---

OLED-scherm

Laadcontacten

Knop



## INHOUD DOOS

ZeFit



USB-oplaadclip

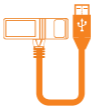

Handleiding





## 2. OPLADEN

---

U moet ZeFit twee uur opladen voordat u het voor de eerste keer gebruikt

1. Plaats de laadpinnen recht tegenover de laadcontacten op de achterkant van de ZeFit
2. Klem de lader stevig over de voorzijde van de ZeFit
3. Steek het grote uiteinde van de USB-kabel in de USB-poort van een computer
4. Er verschijnt een batterij-indicator op het ZeFit scherm die aangeeft dat de batterij wordt opgeladen
5. De ZeFit is opgeladen als de batterij-indicator vol is

Indicator	Status
	Opladen
	Opladen voltooid
	Batterij bijna leeg

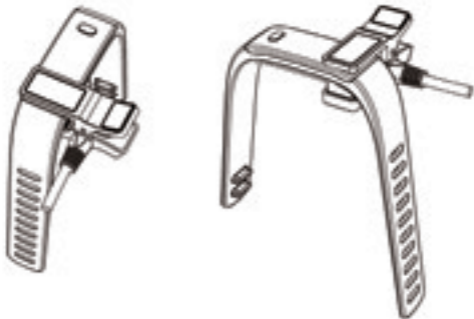

### 3. DRAGEN

---

ZeFit is instelbaar en geschikt voor elke polsmaat.

---

1. Plaats de ZeFit om uw pols en schuif de sluiting over de gaten
  2. Druk een paar keer totdat u een klik hoort. Zorg ervoor dat beide uiteinden van de ZeFit volledig en stevig aan elkaar zijn bevestigd
- 



Voor de meest nauwkeurige gegevens, raden wij u aan om de ZeFit om de pols van uw niet-dominante hand en niet te los te dragen





## 4. INSTELLEN

---

Als u ZeFit voor de eerste keer gebruikt, zal er een bericht verschijnen dat u verzoekt om uw ZeFit via uw mobiele apparaat in te stellen.



### INSTELLEN MET EEN MOBIEL APPARAAT

#### Compatibiliteit met mobiele apparaten

ZeFit is compatibel met Apple iOS-apparaten en een aantal Android apparaten die Bluetooth 4.0 ondersteunen

iOS 6 of hoger

Android 4.3

## DE ZEFIT APP DOWNLOADEN

Om de ZeFit in te stellen met behulp van uw mobiele apparaat, moet u eerst de ZeFit App installeren.

Zoek naar de "ZeFit" App in de App Store of Google Play, download en installeer de App op uw mobiele apparaat.

Als u de ZeFit App opent, kiest u voor **Sign up** indien u een nieuw lid bent of **Log in** indien u een bestaande account heeft. U wordt gevraagd om uw persoonlijke gegevens in te voeren zodat ZeFit kan voorzien in de meest nauwkeurige resultaten van uw prestaties. Deze informatie blijft vertrouwelijk.



## BLUETOOTH-KOPPELING

---

1. Schakel Bluetooth in op uw mobiele apparaat

---

2. Open de ZeFit App op uw mobiele apparaat. U kiest voor **Sign up** indien u een nieuw lid bent of **Log in** indien u een bestaande account heeft

---

3. Nadat u uw persoonlijke gegevens heeft ingevoerd, tikt u op **Set up your ZeFit**

---

4. Zorg ervoor dat ZeFit in de buurt is. Druk op de ZeFit knop om het scherm te activeren. Het ZeFit scherm moet geactiveerd zijn om de koppeling te initiëren

---

5. Uw mobiele apparaat zal op zoek gaan ZeFit. Wanneer het koppelen van de ZeFit is geslaagd, krijgt u een melding op het scherm van uw mobiele apparaat



Het koppelen is uitsluitend nodig bij het eerste gebruik. Indien u uw mobiele apparaat aan een andere ZeFit wilt koppelen, moet u de huidige ZeFit eerst ontkoppelen. Ga naar het tabblad Instellingen van de ZeFit App, ontkoppel de huidige ZeFit en klik op Instellen om een nieuw apparaat te koppelen



1.



3.



4.

*i*

Als uw mobiele apparaat ZeFit niet kan vinden, kunt u het opnieuw proberen. Zorg ervoor dat (1) Bluetooth ingeschakeld is op uw mobiele apparaat (2) de ZeFit App geopend is (3) het ZeFit scherm is geactiveerd

## 5. UW GEGEVENS SYNCHRONISEREN

---

Volg deze stappen om de opgeslagen gegevens op de ZeFit, handmatig en draadloos te synchroniseren met uw mobiele apparaat.

---

1. Open de ZeFit App
  2. Op het **Activity** scherm klikt u op het synchroniseren pictogram  in de rechterbovenhoek
  3. Druk op de ZeFit knop om het scherm te activeren. Het ZeFit scherm moet geactiveerd zijn om de synchronisatie te initiëren
  4. Er verschijnt een pop-up venster op het scherm van uw mobiele apparaat dat het synchroniseren bevestigt
-



2.



3.



4.

## 6. SCHERM

---

Houd de knop kort ingedrukt om uw dagelijkse activiteiten in real time op het ZeFit scherm te bekijken. Gebruik het scherm om de resultaten van uw dagelijkse activiteiten te doorbladeren.

### ACTIVITEIT

Huidige tijd



Aantal stappen

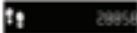

Verbruikte calorieën

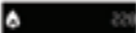

Afgelegde afstand

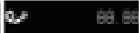

### MODUS

Slaapmodus



Activiteitmodus





## HERINNERINGEN

Sport

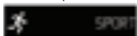

Wakker worden



Slaap

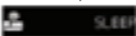

Medicijnen



Eten



Vooraf bepaald

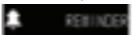

## ANDERE SCHERMWEERGAVEN

Doelstelling bereikt



Geheugen vol



Synchroniseren



*i*

Het ZeFit scherm toont de dagelijkse gegevens. De activiteit tracker wordt om middernacht opnieuw ingesteld

## TIJD & DATUM

ZeFit zal de tijd en datum van uw gekoppelde mobiele apparaat, automatisch synchroniseren. U kunt uw gewenste tijdnotatie handmatig instellen (12 of 24 uur) in het tabblad **Settings** van de ZeFit App.

## 7. ACTIVITEIT

---

ZeFit houdt het aantal stappen, de afgelegde afstand en het aantal calorieën die u overdag heeft verbruikt, bij. U kunt uw activiteitsniveau en geschiedenis bekijken op het tabblad **Activity** van de ZeFit App. Op het **Activity** beginscherm kunt u uw prestatieniveau vergelijken met uw dagelijkse doelstellingen. Klik op het activiteit balkje voor een gedetailleerd overzicht van uw dagelijkse, wekelijkse en maandelijkse prestaties.



Om de meest recente activiteit gegevens te uploaden, tikt u het synchroniseren pictogram aan in de rechterbovenhoek van de ZeFit App en drukt u op de ZeFit knop om het scherm te activeren

## 8. SLAAP

---

ZeFit houdt het aantal uren slaap en de kwaliteit ervan, bij (lichte slaap, diepe slaap, tijd dat u wakker ligt).

- **Slaapmodus starten**

Houd de knop ingedrukt totdat de ZeFit zachtjes trilt en het slaap pictogram op het scherm verschijnt



- **De slaapmodus afsluiten en overschakelen naar de activiteitsmodus**

Houd de knop ingedrukt totdat de ZeFit zachtjes trilt en het zon pictogram en tijd op het scherm verschijnt



*i*

Om de meest recente slaap gegevens te uploaden, tikt u het synchroniseren pictogram aan in de rechterbovenhoek van de ZeFit App en drukt u op de ZeFit knop om het scherm te activeren

## 9. DOELSTELLINGEN

---

Tik het tabblad **Goals** aan van de ZeFit App om de dagelijkse doelstellingen in te stellen voor: aantal stappen, afgelegde afstand, verbruikte calorieën en aantal uren geslapen.

Klik op de synchroniseren knop in de rechterbovenhoek  om uw doelstellingen op te slaan.

Zodra u een van uw dagelijkse doelstellingen heeft bereikt, zal ZeFit zachtjes trillen en "Goal achieved" weergeven



*i*

U kunt uw dagelijkse doelstellingen van de ZeFit App op elk moment wijzigen. Vergeet niet het synchroniseren pictogram aan te tikken om uw nieuwe doelstellingen op te slaan

## 10. HERINNERINGEN

---

Tik het tabblad **Reminders** aan van de ZeFit App om dagelijkse herinneringen toe te voegen. Kies uw type herinnering (sport, eten, slaap, wakker worden, medicijnen, vooraf bepaald), en voer de gewenste tijd en dag in. U kunt een terugkerende herinnering aanmaken en bepalen op welke dagen deze herinnering wordt herhaald. Klik op **Save** om deze nieuwe herinnering toe te voegen; het zal worden opgeslagen tijdens uw volgende synchronisatie.

ZeFit zal zachtjes trillen en het bijhorend herinnering pictogram tonen om u te waarschuwen. Druk op de ZeFit knop om de waarschuwing uit te zetten. Als u de herinnering niet uitzet, zal dezelfde waarschuwing na twee minuten worden herhaald.



U kunt maximaal 6 dagelijkse herinneringen instellen

## 11. TECHNISCHE SPECIFICATIES

---

Afmeting & omtrek	Min: 161 mm /5.7" Max: 209 mm /8.23" Breedte: 20 mm /0.8"
Gewicht	25g
Bluetooth	4.0
Type batterij	Li-ion-60mAh
Autonomie	3 tot 4 dagen
Oplaadtijd	2 uur
Geheugen	7 dagen activiteiten
Scherm	OLED
Sensor	3-assige versnellingsmeter
Bedrijfstemperatuur	-20°C tot +40°C
Waterbestendig	Bestand tegen spatten, transpiratie en regen
Internationale garantie	1 jaar

## OVER DEZE HANDLEIDING

De kenmerken van ZeFit en de inhoud van de handleiding zijn onderhevig aan verandering. Voor de nieuwste instructies met betrekking tot het gebruik van dit product, verwijzen wij u naar de online handleiding die beschikbaar is op [www.mykronoz.com](http://www.mykronoz.com)

## ONDERSTEUNING

Als u vragen of hulp nodig heeft met betrekking tot onze producten, kunt u terecht op [www.mykronoz.com/support](http://www.mykronoz.com/support) of een e-mail sturen naar [support@mykronoz.com](mailto:support@mykronoz.com)

# SAFETY INSTRUCTIONS

---

Before using the device, read these instructions carefully.

- ZeFit has one built-in battery. Do not disassemble the battery on your own. KRONOZ LLC is not responsible for any damage or personnel injury caused by the removal of the battery or any component.
- This device is not waterproof so keep it away from all sources of heat or humidity. Do not use it near sink or other wet areas. Do not place it in water.
- Charge the battery in a cool, ventilated room. Excessive temperature during charging could cause heat, smoke, fire or deformation of the battery or even explosion.
- Avoid excessive temperatures. Do not expose this device to excessive smoke, dust, or direct sunlight for an extended period of time.
- Do not open, crush, bend, deform, puncture or shred secondary cells or batteries. In the event of a battery break or leak, prevent battery liquid contact with skin or eyes. If this happens, immediately flush the areas with water (do not rub the eye) or seek medical help.



- Do not short-circuit. Short-circuiting can occur when a metallic object, such as coins, causes direct connection of positive and negative terminals of the battery. Short-circuiting may damage the battery.
- Do not use batteries that have been damaged or have been exhausted.
- Keep the batteries out of children's reach and in a safe place to prevent danger.
- Do not dispose of batteries in fire as they may cause explosion. Dispose of used batteries in accordance with your local regulations (such as recycling). Do not dispose as household waste.
- Use only the USB cable supplied to charge this battery. Do not charge for more than 24 hours.
- KRONOZ LLC is not responsible for any damage caused by improper use of the device.

# REGULATORY NOTICES

---

## USA



### FCC STATEMENT

This device complies with Part 15 of the FCC Rules. Operation is subject to the following two conditions: (1) This device may not cause harmful interference, and (2) This device must accept any interference received, including interference that may cause undesired operation.

### CAUTIONS

Changes or modifications not expressly approved by the party responsible for compliance could void the user's authority to operate this equipment.

### FCC NOTICE

This equipment complies within the limits of a Class B digital device, pursuant to part 15 of the FCC Rules. These limits are designed to provide reasonable protection against radio and TV interference in residential areas. However, even during normal operation, this equipment may cause TV or radio interference. If this equipment does cause harmful interference to radio or television reception, which can be determined by turning the equipment off and on, the user is encouraged to try one or more of the following corrective measures:

- Reposition the receiving antenna
- Increase the distance between the equipment and receiver
- Connect the equipment into an outlet on a circuit different from which the receiver is connected
- Consult the dealer or an experienced radio/TV technician for help.

FCC ID: 2AA7D--ZEFT1

## EUROPEAN UNION CE DIRECTIVE



Declaration of conformity with regard to the EU Directive 1999/5/EC.

Kronoz LLC hereby declares that this device is in compliance with the essential requirements and other relevant provisions of the R&TTE Directive 1999/5/EC. The complete declaration of conformity is available on request via our customer service: [support@mykronoz.com](mailto:support@mykronoz.com)

Déclaration de conformité à l'égard de la directive européenne 1999/5/CE.

Kronoz LLC déclare que cet appareil est conforme aux exigences essentielles et aux autres dispositions pertinentes de la directive R&TTE 1999/5/CE. La déclaration de conformité complète est disponible sur demande auprès de notre service client: [support@mykronoz.com](mailto:support@mykronoz.com)



## DISPOSAL AND RECYCLING INFORMATION

After the implementation of the European Directive 2002/96/EU in the national legal system, the following applies: Electrical and electronic devices may not be disposed of with domestic waste. Consumers are obliged by law to return electrical and electronic devices at the end of their service lives to the public collecting points set up for this purpose or point of sale. Details to this are defined by the national law of the respective country. This symbol on the product, the instruction manual or the package indicates that a product is subject to these regulations. By recycling, reusing the materials or other forms of utilizing old devices, you are making an important contribution to protecting our environment.

©2014 Kronoz LLC, all rights reserved. Kronoz LLC, Route de Valavran 96, 1294 Genthod, Suisse

All brands or product names are or may be trademarks of their respective owners.

Pictures and specifications are not contractual. Les marques citées sont des marques déposées par leur fabricant respectif. Photos et caractéristiques non contractuelles.

Designed in Switzerland - Made in China



MYX KRONOZ  
MORE THAN TIME

[www.mykronoz.com](http://www.mykronoz.com)

© 2014 KRONOZ LLC. Tous droits réservés