

## Technical Description and Operating Instructions

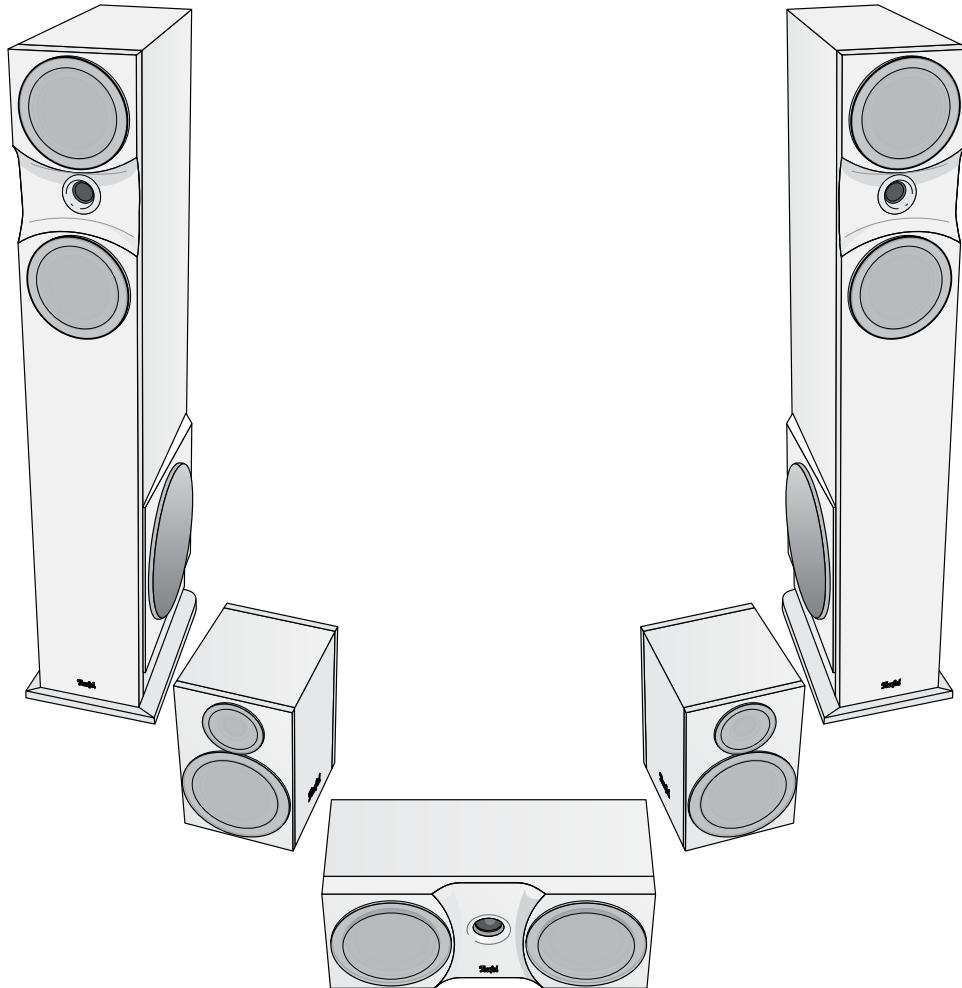

# Theater<sup>®</sup> 6 Hybrid

5.2 Home Cinema Speaker Set with  
two integrated active subwoofers

**Teufel**

# Contents

---

<b>General notes and information .....</b>	<b>3</b>
For your information .....	3
Trademarks .....	3
Complaints.....	3
Contact .....	3
Proper use.....	3
<b>Safety notes .....</b>	<b>4</b>
Safety notes .....	4
<b>Overview .....</b>	<b>5</b>
Checking the product contents.....	5
<b>Setup .....</b>	<b>6</b>
Location tips .....	6
Center speaker .....	6
Front speakers .....	6
Dipole rear speakers .....	6
Wall mounting.....	7
Wall bracket/speaker stand .....	7
<b>Connecting .....</b>	<b>7</b>
Speakers .....	8
Subwoofer – audio connection .....	8
Subwoofer – mains power connection .....	8
<b>Use .....</b>	<b>9</b>
Subwoofer connections and controls .....	9
Activating and deactivating .....	10
Automatic activation/deactivation.....	10
Adjusting the AV receiver and subwoofer.....	10
Stereo amplifier and adjusting the subwoofer .....	10
<b>Care and cleaning .....</b>	<b>11</b>
<b>Troubleshooting.....</b>	<b>11</b>
<b>Protecting the environment .....</b>	<b>12</b>
Disposal of the unit.....	12
<b>Technical data .....</b>	<b>12</b>

## General notes and information

### Notice

The information in this document may change without prior notice and in no way constitutes any liability on the part of Lautsprecher Teufel GmbH.

No part of these instructions may be reproduced in any form or be broadcasted in any way electronically, mechanically, by photocopy or recording without the written permission of Lautsprecher Teufel GmbH.

© Lautsprecher Teufel GmbH  
Version 1.0  
October 2013

### Trademarks

® All trademarks are the property of their respective owners.

### Original packaging

If you wish to exercise your eight-week right of return, we ask that you be absolutely sure to hold onto the packaging. We are only able to accept returned speakers in the ORIGINAL PACKING.

Empty boxes are not available!

### Complaints

In case of complaint we will need the following information to process your enquiry:

#### 1. Invoice number

Can be found on the sales slip (enclosed with the product) or on the order confirmation received as a PDF document, e.g. 4322543

#### 2. Serial number or batch number

Located on the back side of the unit, e.g. serial number: S10....

Many thanks for your support!

### Contact

For questions, suggestions or any other issues please contact our customer service department:

Lautsprecher Teufel GmbH  
Gewerbehof Buelowbogen  
Buelowstrasse 66  
10783 Berlin (Germany)

**Phone 00800 - 200 300 40 (toll-free)**

**Fax: +49 (0)30 / 300 930 930**

**E-mail: [service@teufelaudio.com](mailto:service@teufelaudio.com)**

**[www.teufelaudio.com](http://www.teufelaudio.com)**

### Proper use

Only use the unit as described in these operating instructions. Any other use will be deemed as not in accordance with the instructions and may lead to damage of property or even persons.

The manufacturer accepts no liability for damage caused by use not in accordance with the instructions.

The unit is intended for private use.



Before operating the speakers please read the safety notes and operating instructions carefully.

This is the only way to use all functions safely and reliably.

Keep the operating instructions safe and pass them on to anyone who may own the unit after you.

## Safety notes

### Caution icons

You will find the following caution icons in these instructions:

---

**Danger High risk!**

Failure to observe the warning may result in severe personal injury or death.

---

**Attention Moderate risk!**

Failure to observe the warning may result in property damage.



---

**Minor risk!**

Points which should be observed when handling the unit.

---

### Safety notes

---

**Danger Risk of electric shock!**

Faulty installation of electrical equipment or mains voltage which is too high can cause electric shocks.

- The unit is suitable for connection to a mains voltage of 220V – 240V~ / 50Hz only. Make sure that the mains voltage is correct. For more information, refer to the nameplate.
  - Check the unit regularly for damage.  
If the unit's case or mains cable is defective or shows other signs of visible damage, disconnect the power plug / mains adapter immediately from the socket and do not operate the device.
  - If the unit emits smoke or smells of burning or other unusual odours, disconnect it immediately from the power supply and do not operate it anymore.
  - Never open the unit's housing.  
Repairs may only be carried out by an authorised specialist workshop. Only parts which conform with the original unit specifications may be used in this case. There are electrical and mechanical parts in this unit which are necessary in order to avoid exposure to sources of danger.
  - Use only accessories specified by the manufacturer.
  - Do not insert any objects through the vent slots in the housing.
  - Only use the unit in indoor areas.
  - Do not operate the unit in damp areas and protect it from drops of water or splash water.  
Also take care not to stand vases or other containers filled with liquid on or near the speaker in order to avoid liquid getting into the case. If water or other foreign objects should enter the unit, immediately disconnect the mains plug. Then send the unit to our service address.
  - Never touch the mains adapter with damp hands.
- 

---

**Danger Danger to children!**

Children can become trapped in the packing film when playing and suffocate.

- Do not allow children to play with the unit or the packing film. Danger of suffocation.
  - Ensure that children do not remove small parts from the unit or take them off of the unit (e.g. control knobs or plug adapters). They could swallow the parts and choke.  
Never allow children to operate electrical units unsupervised.
- 



---

**Danger to hearing!**

Extended listening at high volumes may lead to hearing loss.

- To avoid damage to health, avoid extended listening at high volumes.
  - When the volume is set high, always keep a certain distance from the unit and never place your ear directly on the speaker.
  - Particularly when the subwoofer has been set to maximum volume and the unit is activated, very high noise pressure may suddenly be produced. This may have psychological consequences and also cause physical injury. Children and pets are particularly at risk. Set your signal source unit volume control to a low setting before turning on the power.
- 

---

**Danger Danger of injury/damage!**

An unstable base may cause the unit to tip and injure or even kill persons, children are particularly at risk. You can prevent many accidents by taking the following precautions:

- Place the speakers in such a way that they cannot be knocked over unseen and make sure that the cables do not pose a trip hazard.
  - Only place the subwoofer on the floor.
  - If you want to use underframes or speaker stands, only use those recommended by the manufacturer.
  - If mounting the speakers on the wall, make sure that the job is carried out by a professional.
  - Only use suitable wall brackets for mounting. Verify the carrying capacity of the walls.
  - Do not place the unit near sources of heat (e.g. heaters, ovens, other heat generating equipment such as amplifiers etc.).
-

### Attention Fire hazard!



Improper use may lead to damage or fire.

- Do not place open flames such as burning candles or similar on the unit.
- Ensure sufficient ventilation.
- Do not place the unit in direct sunlight.
- Do not cover the vents with curtains, blankets, newspapers or similar. Heat build-up inside the unit can shorten its lifetime.

### Attention Risk of damage!



Power overload due to lightning strike may damage or destroy the unit.

- If the unit is unattended for a prolonged period (e.g. when on vacation) or in the event of an incoming storm, pull the power plug.
- If the device is subjected to warm temperatures after being cold (e.g. after transport), condensation may occur inside of it. In this case, wait at least 2 hours before you connect and activate it.

## Explanation of symbols

	Safety category II Dual insulation
	Danger of electric shock – do not open casing. Disconnect power cord before changing fuse.
	Fuse T 1.6 AL / 250 V

## Overview

### Product contents

- ① 2 x front speaker H 600 F
- ② 1 x center speaker H 600 C
- ③ 2 x dipole rear speaker H 600 D
- ④ 2 x power cord for front speaker H 600 F
- ⑤ 4 x rubber cushions für dipole rear speaker H 600 D



### Connector cables

Due to diverse different customer requirements the Theater 6 series is shipped without any connector cables. You will find suitable cables in our online shop ([www.teuelaudio.com](http://www.teuelaudio.com)) under "Accessories". Amongst other things, you will also find suitable speaker stands there.

### Checking the product contents

- Check that all items have been delivered and that nothing is damaged. If the delivery is incomplete or you find damage sustained in transit, contact our service department (see page 3).
- Do not use damaged articles.

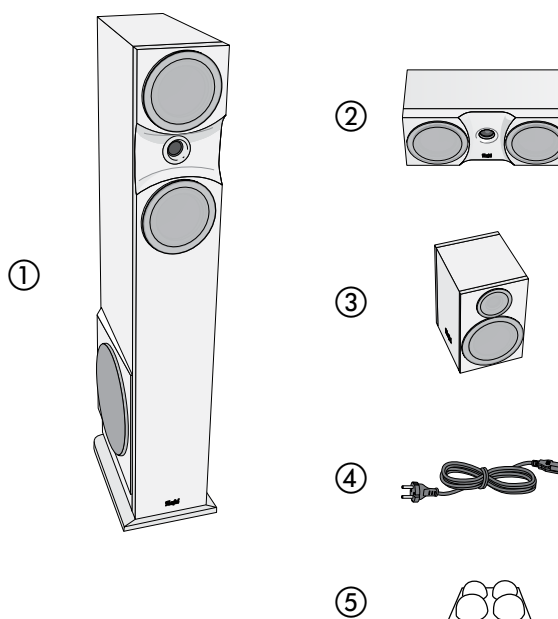

# Setup

## Location tips

- Select a stable, level base.
- Make sure that the environment is clean and free from dust.
- Avoid placing the unit close to sources of heat or in direct sunlight.
- Do not place any heavy objects on the cables or the speakers.
- Mounting material especially attuned to these speakers (cables, speaker stands, wall mount brackets and isolation pads) is available via our web shop.

The following data refers to an "ideal home cinema", in which the viewer or listener sits in a central position at sufficient distance in front of the television or screen (see graphic to the right) and no objects (tables or the like) are located in between. Unfortunately, the room, furnishings or other circumstances do not always allow for optimum arrangement.

Modern AV receivers offer many ways to compensate for any deficiencies in placement. The following general rule applies: You can always experiment on what works best in your listening room in terms of sound and appearance based on our recommendations. Let your ears (and eyes) decide!

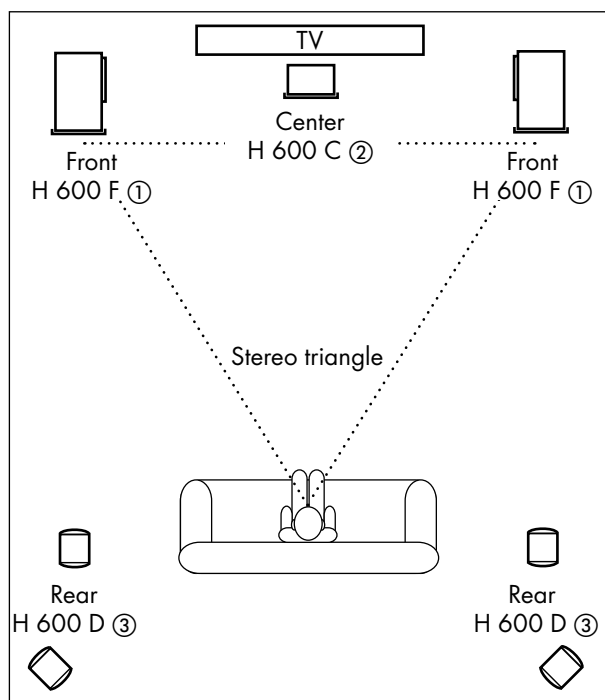

## Center speaker

- Place the center speaker ② directly centred under the screen.

## Front speakers

- The two front speakers ① are placed to the right and left of the screen.
- They should form, as far as possible, an equilateral triangle with the listener – what is known as the stereo triangle (distance to listener = distance between speakers).
- The laterally placed subwoofer can point inwards (towards the centre of the room) or outwards (towards the room wall). If the subwoofer is projecting sound towards the wall a higher bass level is to be expected. Experimentalize which ratio delivers the best sound in your room according to your listening sensation.
- The speakers should project sound directly into the room or slightly towards the listener.

## Dipole rear speakers

A toggle switch is located between the connector terminals of the dipole rear speakers H 600 D. You can use it to switch between normal and dipole mode. The sound is emitted from the front and back in dipole mode.

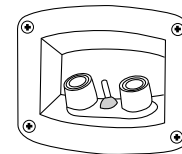

There are two possible arrangements for these speakers:

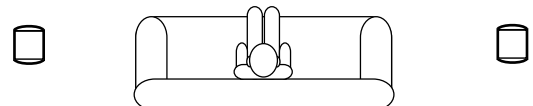

Normally, the dipole rear speakers are set up or hung up at head height (140 to 210 cm) to the side of the listener. In the process, the speakers are switched to dipole mode and project sound to the front and back. The distance to the rear wall should be no less than 10 cm.

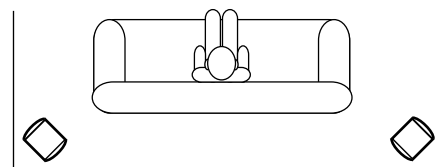

The second arrangement possibility is suitable for narrow rooms. In this case, the rear speakers are placed at a height of 140 to 210 cm behind the listener and situated at a 45 degree angle. This way, the speakers project sound towards the walls and produce the desired spatial diffusion in dipole mode. The distance to the walls should not be less than 10 cm in this case.

## Wall mounting

If you choose to mount your speakers on the wall please note the following:

### Attention Risk of damage!



Unsuitable fixing may cause damage.

- If mounting the speakers on the wall, make sure that the job is carried out by a professional.
- Before drilling the holes use a metal detector to ensure that there are no electrical or plumbing runs in the wall within the drilling area.
- Use only suitable screws and wall plugs for fixing. Verify the carrying capacity of the walls.

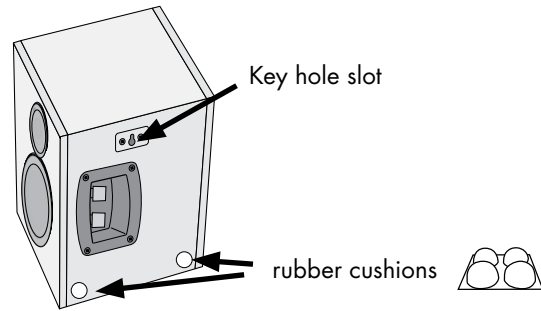

- Glue each 2 of the included self-adhesive rubber cushions to the inner side of the H 600 D.
- Hang the dipole rear speakers on the wall using the keyhole slot(s) on the back of the speakers and the previously mounted screw(s).

## Wall bracket/speaker stand

- The keyhole slot(s) and the threaded holes on the bottom of the speakers are also intended for fixing the speakers to a wall bracket or speaker stand. You will find suitable items in our online shop.

## Connecting

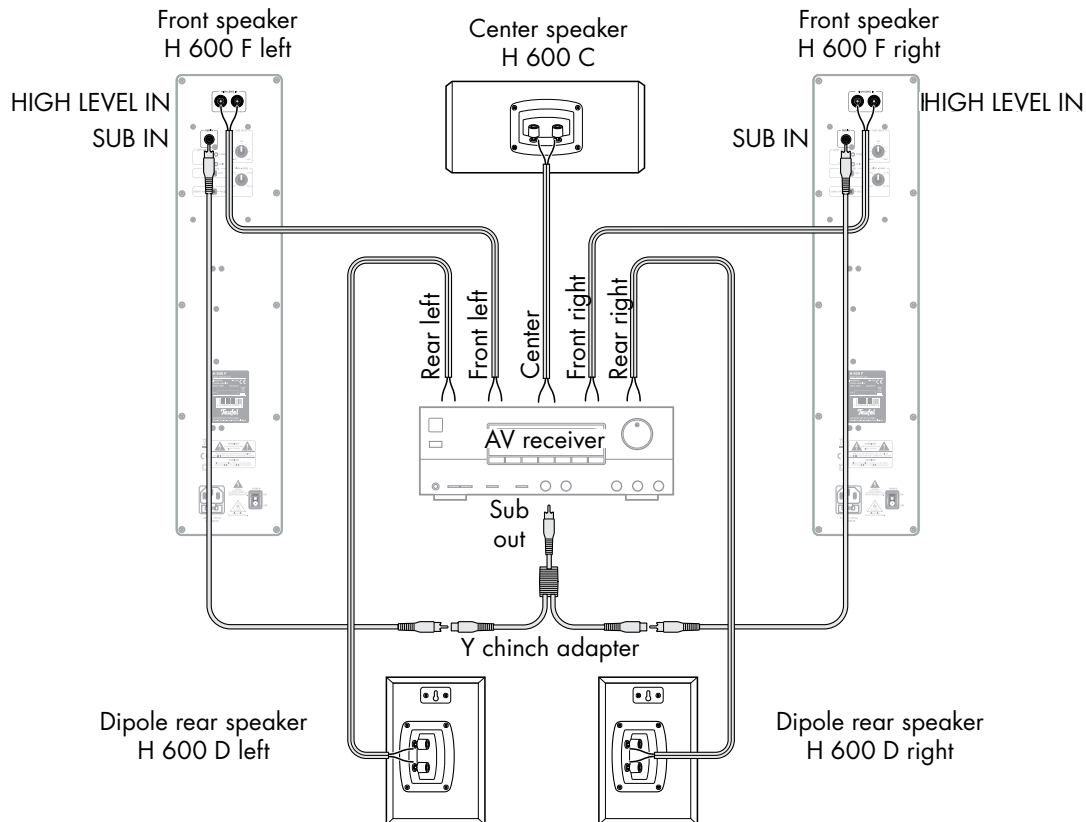

**Danger Danger of injury/damage!**



Arrange the cables so that they do not pose a trip hazard.

- Unplug the mains plug of your AV receiver from the mains power supply so that it cannot be switched on by accident.

**Speakers**

- Lay speaker cable from your AV receiver to each speaker. Use a high-quality double wire speaker cable with marked strands for this. The cable should have a diameter of at least 2.5 mm<sup>2</sup>.  
Little hint: label the cables at the receiver end – this will help if you ever need to disconnect and reconnect the receiver.
- On the back of each speaker is a connection terminal with two clamps. Here you can connect the speaker cables directly or using pin plugs. Direct connection only is described here.
- For the two front speakers those are the jacks **1** "HIGH LEVEL IN".

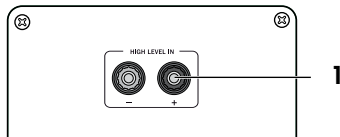

- The terminals are each marked red (+) and black (-).



**Make sure the polarity is correct!**

Connect the like coloured terminals. Otherwise the sound quality will suffer. The speaker connections on your AV receiver should be similarly marked. The strands of the speaker cables are marked with different colours or shapes.

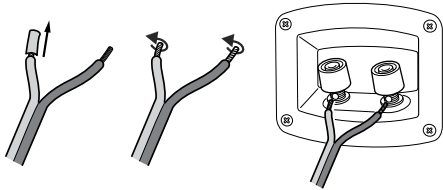

- Split the wire down by approx. 30 mm on both ends and remove approx. 10 mm of insulation each. Twist the wire so that no strands are protruding.
- Turn the connector terminal counterclockwise until loose. Run the stripped cable end into the now visible hole. Close the terminal by turning it counterclockwise. The cable has now been clamped in place.
- Connect all the cables to the speakers in the same way.
- Connect the other ends of the speaker cables to your AV receiver. You should be able to find corresponding notes in the operating instructions of your device.

**Subwoofer – audio connection**

With the switch **7** "INPUT" you determine the connection method for the integrated active subwoofer:

- "STEREO AMP" – the amplifier doesn't feature a subwoofer output and the subwoofer receives its signal from connection "HIGH LEVEL IN".
- "AV RECEIVER" – the amplifier features a subwoofer output and the subwoofer receives its signal via the chinch connection "SUB IN".

**Connection via HIGH LEVEL IN**

As the front speakers were connected in the previous section already, you don't need another cable.

**Connection via SUB IN**

The subwoofers are connected to the subwoofer output of the AV receiver using a mono chinch cable each (not included in the product contents). If your AV receiver has only one subwoofer output, you also need a Y chinch cable. Insert the chinch plugs in the jack **12** "SUB IN" each.

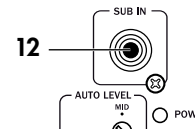

**Subwoofer – mains power connection**

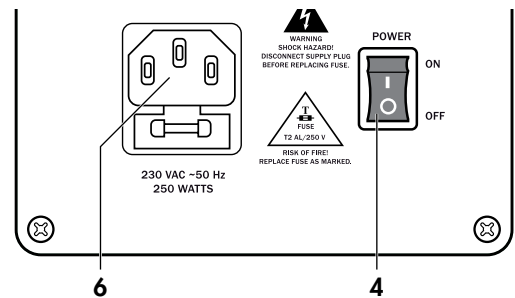

- Ensure that the mains switch **4** "POWER" is set to "OFF".
- Using power cord **4**, connect the mains connection jack **6** to a mains power socket.
- Also plug your AV receiver back into the mains power supply.



## Subwoofer connections and controls

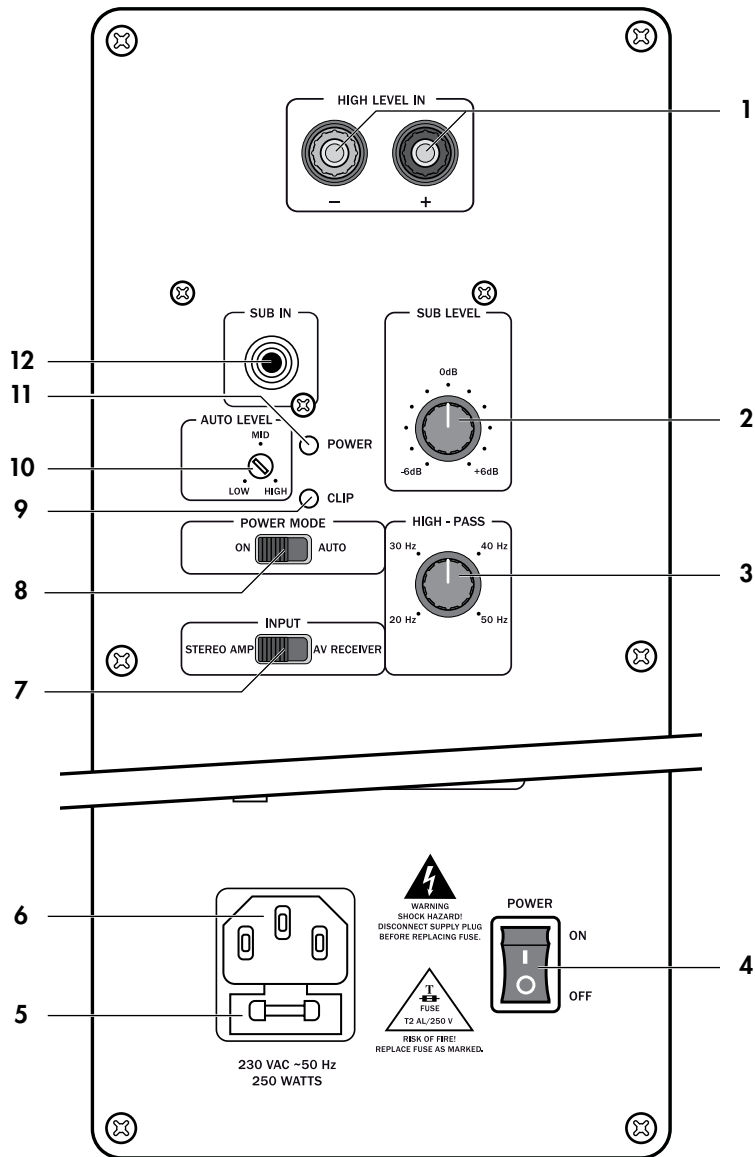

Item	Name	Description	Item	Name	Description
1	<b>HIGH LEVEL IN</b>	Speaker connection	8	<b>POWER MODE</b>	Automatic activation/deactivation or permanent activation
2	<b>SUB LEVEL</b>	Volume control for subwoofer	9	<b>CLIP</b>	Overload indicator (red)
3	<b>HIGH-PASS</b>	Control for frequency above which the subwoofer operates	10	<b>AUTO LEVEL</b>	Controller for activation sensitivity of automatic activation/deactivation function
4	<b>POWER ON/OFF</b>	Mains switch	11	<b>POWER</b>	Power LED (green = on, red = sleep mode/standby)
5	-	Mains fuse	12	<b>SUB IN</b>	Chinch connection for the subwoofer
6	-	Connector jack for power cord ④			
7	<b>INPUT</b>	Selector switch for subwoofer input			

## Activating and deactivating

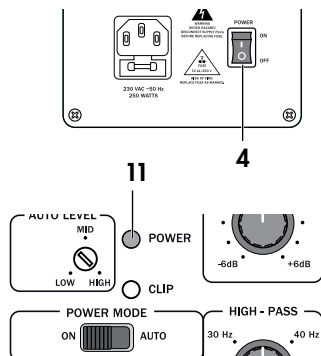

- Use mains switch **4** "Power" to switch the main power supply on or off. When the subwoofer is activated, the power LED **11** "Power" is green. If the subwoofer is in standby, it is red.

## Automatic activation/deactivation

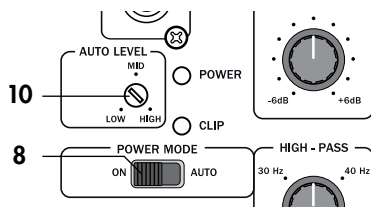

You can toggle between the operating modes with the switch **8** "POWER MODE":

**ON** The subwoofer is permanently switched on.

**AUTO** The subwoofer switches itself on as soon as an audio signal is present. If there's no audio signal for approx. 20 minutes, the subwoofer switches to standby. If the auto-function doesn't switch correctly, you can increase or decrease the sensitivity using the controller **10** "AUTO LEVEL" by turning it clockwise (to increase it) or counter-clockwise (to decrease it). You will need a small screwdriver to do this.

## Adjusting the AV receiver and subwoofer

**Note:** The following settings only apply for the subwoofer connection via chinch cables.

Most AV receivers have a menu with settings for the speakers (called "Speaker Setup" or similar).

### AV receiver settings

If possible, use the AV receiver's calibration function so that it adjusts the levels, phase and run times to the room. If your receiver doesn't provide an automatic calibration function, the following values are recommended:

- Subwoofer to "On".
- Front speaker size to "Small/Klein".
- Crossover frequency for subwoofer to 90 to 120 Hz.
- Choose the settings for the controllers **2** and **3** as described in the section "Stereo amplifier and adjusting the subwoofer".

## Subwoofer settings

- Switch **8** "POWER MODE" to "AUTO".
- Switch **7** "INPUT" to "AV RECEIVER".

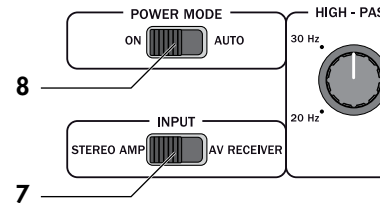

You can carry out the final fine tuning later on your AV receiver.

## Stereo amplifier and adjusting the subwoofer

**Note:** The following settings only apply for the subwoofer connection via the speaker connections **1** "HIGH LEVEL IN".

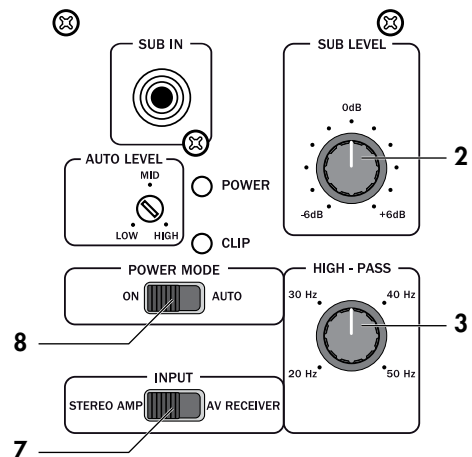

- Switch **8** "POWER MODE" to "AUTO".
- Switch **7** "INPUT" to "STEREO AMP".
- Volume control **2** "SUB LEVEL" to medium setting ("0 dB").
- Set controller **3** "HIGH-PASS" to "20 Hz". This determines the frequency at which the subwoofer starts to play back bass tones.
- Perform an audio test now and adjust the volume control **2** "SUB LEVEL" until the subwoofer can be "easily heard". However, it must not drone. If any deep "hits" are too hard increase the setting on control **3** "HIGH-PASS".
- Repeat these steps with different CDs and DVDs.

## Care and cleaning

Clean the subwoofer and satellite speakers regularly with a soft, slightly damp microfibre cloth. Please be absolutely sure to observe the following notes in the process:

### Danger Risk of electric shock!



In contact with live parts, water can lead to electric shock or short circuit.

- Disconnect the mains plug before cleaning.
- Make sure that no liquid penetrates the unit.

### Attention Risk of damage!



Using the wrong cleaning materials may damage the delicate surface of the case.

- If possible, only use plain water without any additives. In case of stubborn marks, a mild soap solution may be used.
- In no circumstances should caustic cleaning products, white spirit, thinners, petrol or similar be used for cleaning.

## Troubleshooting

The following notes and further detailed **information on our website** should help you to rectify malfunctions. In case you don't succeed, please contact our hotline ☎Phone 00800 - 200 300 40 (toll-free). Please also observe the warranty notes.

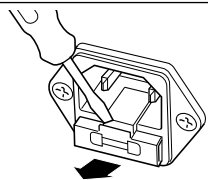
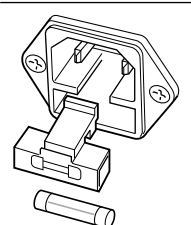
Problem	Possible cause	Solution
The subwoofer isn't working.	The subwoofer is off or doesn't have any power.	Activate the switches <b>4</b> and <b>8</b> ("On"). Check the power cord and socket.
	The overload protection has been triggered and the indicator lamp <b>9</b> "CLIP" is illuminated in red.	Let the device cool off and slightly reduce the level using control <b>2</b> "SUB LEVEL".
	Fuse defective.	<div style="display: flex; justify-content: space-around;"> <div style="text-align: center;">  <p>1.</p> </div> <div style="text-align: center;">  <p>2.</p> </div> </div> <p>Disconnect the power cord. Carefully pull the fuse holder out of the mains connection.</p> <p>Push the old fuse down and out. Insert a new fuse (T 1.6 A, 250 V) and push the holder back in.</p>
	The volume has been set too low.	Increase the volume using control <b>2</b> .
The subwoofer hums.	The subwoofer is connected to a different power circuit from the rest of the system.	Connect the subwoofer and AV receiver to the same power circuit.
	The buzzing is caused by problems with the power supply.	Purchase a line filter and connect both units to it.
	The buzzing is caused by a multiple socket.	Use another multi-outlet power strip or connect the subwoofer directly to the wall socket. It may also help to insert the power plug the other way around.
Playback is noisy.	Generally-speaking, the system is very low-noise. In the high range area, very high-resolution speaker systems can expose the poor quality of a signal source (e.g. from MP3 files).	Make sure that the source is emitting a clear signal.
The sound seems flat.	Satellites have been connected with the poles reversed.	Check that the speaker cable on all satellites is correctly connected.

## Protecting the environment

### Disposal of the unit



**Used units must not be disposed of with household waste!**

If the unit is no longer operational, every consumer is required by law to dispose of used units separately from household waste, e.g. at a collection point run by the communal authority/borough.

In this way it is ensured, that used units are properly recycled and that negative consequences on the environment are avoided.

For this reason, electrical equipment is labelled with the displayed symbol.

## Technical data

	Front speaker with active subwoofer H 600 F	Center speaker H 600 C	Dipole rear speakers H 600 D
Dimensions (WxHxD)	24 x 115 x 41 cm	42 x 18 x 19 cm	21 x 26.5 x 17 cm
Weight	28.5 kg	5.8 kg	4.4 kg
Impedance	4–8 ohm	4–8 ohm	4–8 ohm
Minimum amplifier power	20 watts	20 watts	20 watts
Operating voltage	230 VAC ~50 Hz	–	–
Power consumption in standby	less than 0,5 Watt	–	–

You will find more technical details in the product description on our website at [www.teufelaudio.com](http://www.teufelaudio.com).

Technical changes reserved!

 This product complies with the directives of the Council of the European Community 2004/108/EC and 2006/95/EC.

# Teufel

For questions, suggestions or other issues please contact our customer service department:

**Lautsprecher Teufel GmbH**  
Gewerbehof Buelowbogen - Ausgang D1  
10783 Berlin (Germany), Buelowstr. 66

Tel.: 00800 200 300 40 (toll-free)  
Fax: +49 (0)30-300930930  
[www.teufelaudio.com](http://www.teufelaudio.com)

No liability is accepted for the accuracy of this information. Technical changes, typographical errors and other errors reserved.