



Contact SAMSUNG WORLDWIDE

If you have any questions or comments relating to Samsung products, please contact the SAMSUNG customer care centre.

Country	Customer Care Centre ☎	Web Site
EIRE	0818 717 100	www.samsung.com/ie
U.K	0845 SAMSUNG (7267864)	www.samsung.com/uk

SERIES
6

LED TV user manual

imagine the possibilities

Thank you for purchasing this Samsung product.
To receive more complete service, please register
your product at

www.samsung.com/register

Model _____ Serial No. _____



BN68-01968C-00

Accessories

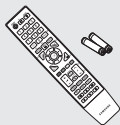

Remote Control & Batteries (AAA
x 2)



Stand Screw (M4 X L10)

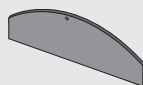

Cover-Bottom



Cleaning Cloth



Holder-Wire (3ea)
connector connector



Holder-Wire Stand



Holder-Ring (4ea)



Holder-Wire Cable
(Depending on the model)



Component Cable



SCART Cable



AV Cable

- Owner's Instructions

- ☑ Please make sure the following items are included with your LED TV. If any items are missing, contact your dealer.
- ☑ The items colour and shape may vary depending on the model.

❑ Precautions When Displaying a Still Image

A still image may cause permanent damage to the TV screen.

■ WARNINGS:

Image retention, commonly known as screen burn-in, can occur on most types of television if the same image is displayed continuously. The most common causes of image retention are logos that remain stationary on the TV screen. These logos are common on many programmes received via a Setop Box.

To reduce this risk, avoid displaying still images for long durations and lower the brightness or contrast settings to decrease the intensity of the picture. Extended viewing of movies and programs in aspect ratios that are different from the aspect ratio of the TV may cause image retention. Always endeavour to avoid black borders top or bottom by using the zoom function. This will help eliminate the black borders and fit the picture to the entire area of the screen. Using a video game console may cause image retention and is not recommended. When using a PC input, avoid displaying still images for long durations and reduce the brightness or contrast settings to decrease the intensity of the picture.

■ IMPORTANT:

Image retention issues are not covered by your Samsung® warranty.

❑ Digital TV (DVB-T) Notice

1. **FUNCTIONALITIES RELATED TO DIGITAL TV (DVB) ARE ONLY AVAILABLE IN COUNTRIES OR AREAS WHERE DVBT (MPEG2 AND MPEG4 AVC) DIGITAL TERRESTRIAL SIGNALS ARE BROADCAST.** DVB-T is the European consortium standard for the broadcast transmission of digital terrestrial television. Please check with your local dealer about the availability of DVB-T service in your area.
2. Although this TV set meets the current DVB-T standards as of [August, 2008], compatibility with future DVB-T digital terrestrial broadcast cannot be guaranteed.
3. Some Digital TV functions may not be available or operate correctly in some countries or regions.
4. For more information, please contact your local SAMSUNG customer care centre.

❑ Precautions When Displaying a Still Image

A still image may cause permanent damage to the TV screen.

- Do not display still image and partially still on the LED panel for more than 2 hours as it can cause screen image retention. This image retention is also known as screen burn. To avoid such image retention, reduce the degree of brightness and contrast of the screen when displaying a still image.



- Watching the LED TV in 4:3 format for a long period of time may leave traces of borders displayed on the left, right and centre of the screen caused by the difference of light emission on the screen. Playing a DVD or a game console may cause a similar effect to the screen. Damages caused by the above effect are not covered by the Warranty.
- Displaying still images from Video games and PC for longer than a certain period of time may produce partial after-images. To prevent this effect, reduce the 'brightness' and 'contrast' when displaying still images.

CONTENTS

Setting up Your TV

- Viewing the Control Panel 2
- Accessories 3
- Viewing the Connection Panel 4
- Viewing the Remote Control 7
- Installing Batteries in the Remote Control 8
- Viewing the menus 9
- Plug & Play Feature 10

CHANNEL

- Channel Menu 11
- Managing Channels 14

PICTURE

- Configuring the Picture Menu 16
- Using Your TV as a Computer (PC) Display 20
- Setting up the TV with your PC 21

SOUND

- Configuring the Sound Menu 22
- Selecting the Sound Mode 23

SETUP

- Configuring the Setup Menu 24
- Setting the Time 26

INPUT / SUPPORT

- Input Menu 28
- Support Menu 28

Media Play (USB)

- Connecting a USB Device 30
- Media Play Function 31
- Sorting the Photo List 32
- Photo List Option Menu 33
- Viewing a Photo or Slide Show 34
- Slide Show Option Menu 35
- Sorting the Music List 37
- Music List Option Menu 38
- Playing a Music 39
- Using the Setup Menu 40
- Music Play option Menu 40

ANYNET+

- Connecting Anynet+ Devices 41
- Setting Up Anynet+ 42
- Switching between Anynet+ Devices 42
- Recording 43
- Listening through a Receiver (Home theatre) 43
- Troubleshooting for Anynet+ 44

RECOMMENDATIONS

- Teletext Feature 45
- Installing the Stand 46
- Disconnecting the Stand 46
- Installing the Wall Mount Kit 47
- Anti-Theft Kensington Lock 47
- Preparing before installing Wall-Mount 47
- Securing the TV to the Wall 48
- Troubleshooting: Before Contacting Service Personnel 49
- Specifications 50
- Warning! Important Safety Instructions
- Wiring the Mains Power Supply Plug (UK Only)
- Warranty Card

□ License



TruSurround HD, SRS and  symbol are trademarks of SRS Labs, Inc. TruSurround HD technology is incorporated under license from SRS Labs, Inc.



Manufactured under license from Dolby Laboratories. Dolby and the double-D symbol are trademarks of Dolby Laboratories.

□ Symbol



Note



One-Touch Button



TOOL Button









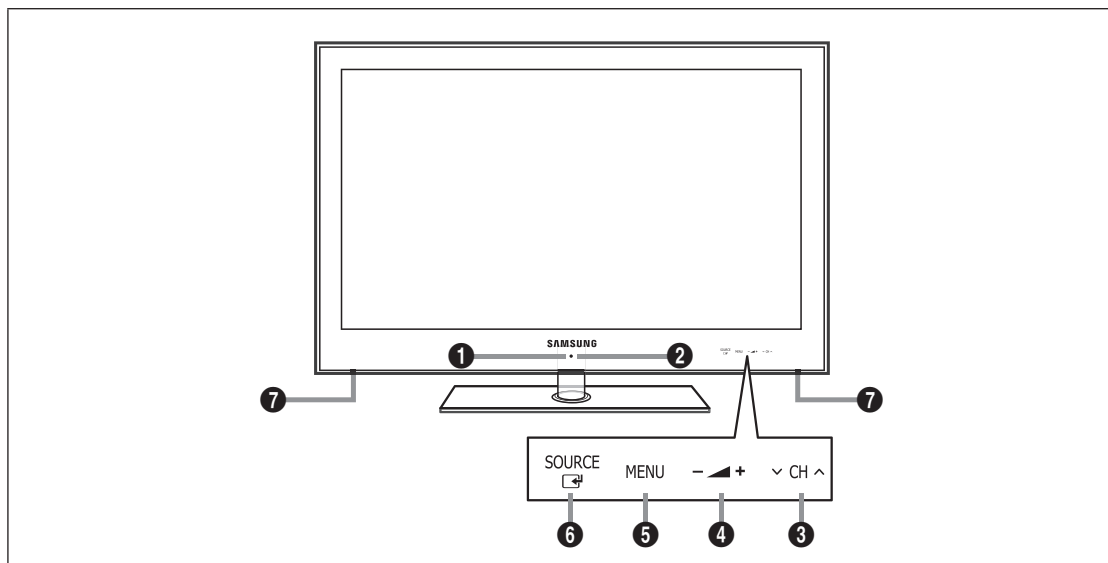





SETTING UP YOUR TV

- ☑ Figures and illustrations in this User Manual are provided for reference only and may differ from actual product appearance. Product design and specifications may be changed without notice in order to enhance product performance.

Viewing the Control Panel

- ☑ The product colour and shape may vary depending on the model.
☑ The front panel buttons can be activated by touching it with your finger.



- 1 REMOTE CONTROL SENSOR:** Aim the remote control towards this spot on the TV.
- 2  (POWER):** Press to turn the TV on and off.
- 3  CH **: Press to change channels. In the on-screen menu, use the  CH  buttons as you would use the  and  buttons on the remote control.
- 4  **: Press to increase or decrease the volume. In the on-screen menu, use the   buttons as you would use the  and  buttons on the remote control.
- 5 MENU:** Press to see an on-screen menu of your TV's features.
- 6 SOURCE **: Toggles between all the available input sources. In the on-screen menu, use this button as you use the **ENTER ** button on the remote control.
- 7 SPEAKERS**

Viewing the Connection Panel

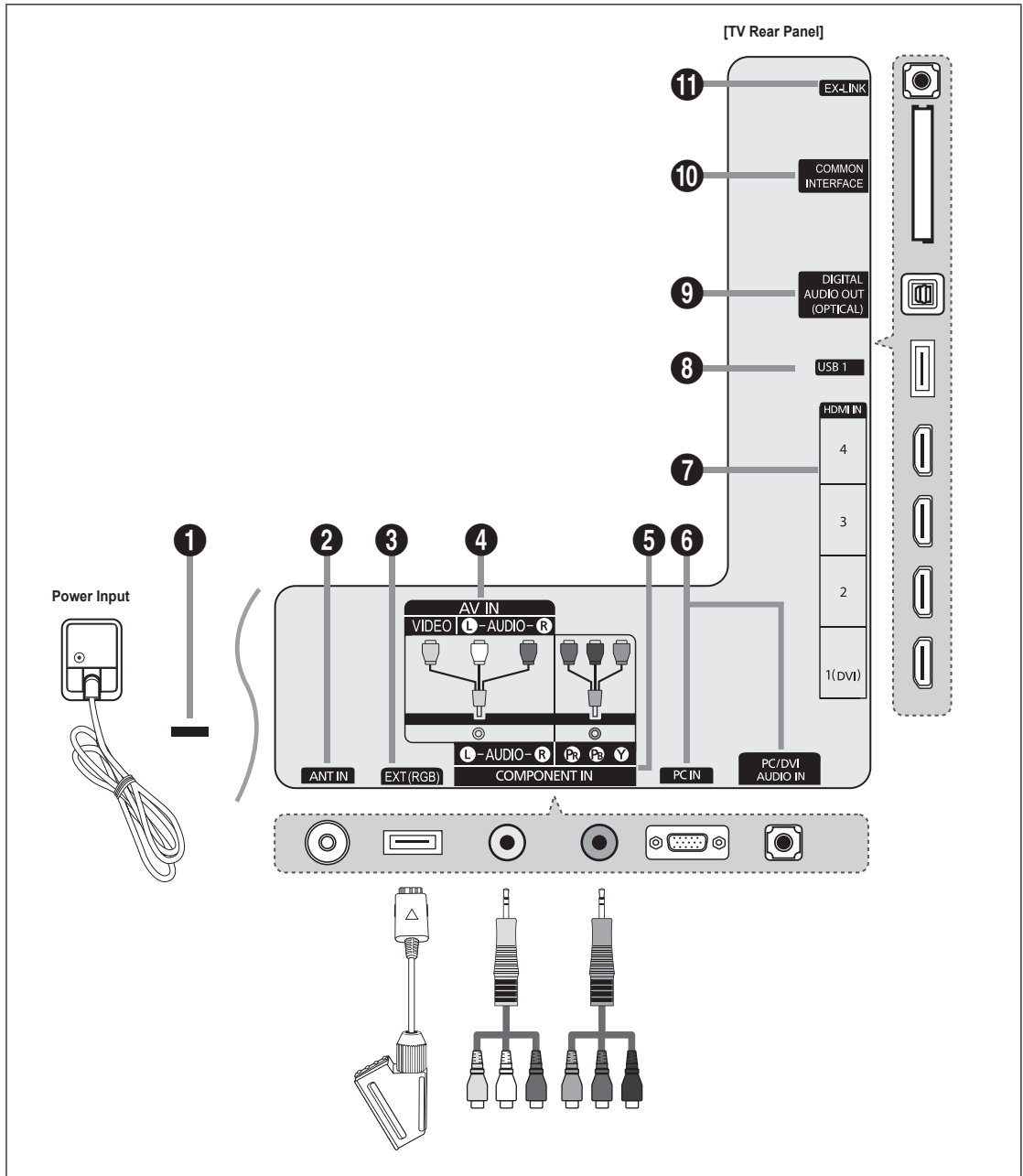

☑ The product colour and shape may vary depending on the model.

1 KENSINGTON LOCK

The Kensington Lock (optional) is a device used to physically fix the system when used in a public place. If you want to use a locking device, contact the dealer where you purchased the TV.

☑ The location of the Kensington Lock may be different depending on its model.

☑ When connecting, use the appropriate connector.

2 ANT IN

Connects to an antenna or cable TV system.

3 EXT (RGB)

Inputs or outputs for external devices, such as VCR, DVD, video game device or video disc players.

- ☑ When connecting, use the appropriate connector.
- ☑ In EXT Mode, DTV Out supports MPEG SD Video and Audio only.
- Input/Output Specification

Connector	Input			Output
	Video	Audio (L / R)	RGB	Video + Audio (L / R)
EXT	O	O	O	Only TV or DTV output is available.

4 AV IN [VIDEO] / [R-AUDIO-L]

Video and audio inputs for external devices, such as a camcorder or VCR.

- ☑ When connecting, use the appropriate connector.

5 COMPONENT IN

Connects Component video / audio.

- ☑ When connecting, use the appropriate connector.

6 PC IN / PC/DVI AUDIO IN

Connects to the video and audio output jacks on your PC.

- ☑ If your PC supports an HDMI connection, you can connect this to the **HDMI IN 1(DVI), 2, 3 or 4** terminal.
- ☑ If your PC supports a DVI connection, you can connect this to the **HDMI IN 1(DVI) / PC/DVI AUDIO IN** terminal.

7 HDMI IN 1(DVI), 2, 3, 4 / PC/DVI AUDIO IN

Connects to the HDMI jack of a device with an HDMI output.

- ☑ No sound connection is needed for an HDMI to HDMI connection.
- ☑ Use the DVI audio cable which is smaller than 14.4mm.
- ☑ What is HDMI?
 - HDMI(High-Definition Multimedia Interface), is an interface that enables the transmission of digital audio and video signals using a single cable.
 - The difference between HDMI and DVI is that the HDMI device is smaller than DVI's one.
- ☑ The TV may not output sound and pictures may be displayed with abnormal colour when DVD / Blu-ray player / Cable Box / Satellite receiver (Set-Top Box) supporting HDMI versions older than 1.3 are connected. When connecting an older HDMI cable and there is no sound, connect the HDMI cable to the **HDMI IN 1(DVI)** jack and the audio cables to the **PC/DVI AUDIO IN** jacks on the back of the TV. If this happens, contact the company that provided the DVD / Blu-ray player / Cable Box / Satellite receiver (Set-Top Box) to confirm the HDMI version, then request an upgrade.
- ☑ Use the **HDMI IN 1(DVI)** jack for DVI connection to an external device. Use a DVI to HDMI cable or DVI-HDMI adapter (DVI to HDMI) for video connection and the **PC/DVI AUDIO IN** jacks for audio. When using an HDMI / DVI cable connection, you must use the **HDMI IN 1(DVI)** jack.
- ☑ HDMI cables that are not 1.3 may cause annoying flicker or no screen display.

8 USB1(HDD)

Connector for software upgrades and Media Play, etc.

9 DIGITAL AUDIO OUT (OPTICAL)

Connects to a Digital Audio component such as a Home theatre receiver.

- ☑ When a Digital Audio System is connected to the **DIGITAL AUDIO OUT (OPTICAL)** jack: Decrease the volume of the TV and adjust the volume level with the system's volume control.
- ☑ 5.1CH audio is possible when the TV is connected to an external device supporting 5.1CH.
- ☑ When the receiver (home theatre) is set to On, you can hear sound output from the TV's Optical jack. When the TV is displaying a DTV(air) signal, the TV will send out 5.1 channel sound to the Home theatre receiver. When the source is a digital component such as a DVD / Blu-ray player / Cable Box / Satellite receiver (Set-Top Box) and is connected to the TV via HDMI, only 2 channel sound will be heard from the Home Theatre receiver. If you want to hear 5.1 channel audio, connect the digital audio out jack on DVD / Blu-ray player / Cable Box / Satellite receiver (Set-Top Box) directly to an Amplifier or Home Theatre, not the TV.

⑩ COMMON INTERFACE Slot

Insert CI (Common Interface) card into the slot.









- When not inserting 'CI CARD' in some channels, 'Scrambled Signal' is displayed on the screen.
- The pairing information containing a telephone number, CI CARD ID, Host ID and other information will be displayed in about 2~3 minutes. If an error message is displayed, please contact your service provider.
- When the channel information configuration has finished, the message 'Updating Completed' is displayed, indicating that the channel list is now updated.
- ✍ You must obtain a CI CARD from a local cable service provider. Remove the CI CARD by carefully pulling it out with your hands since dropping the CI CARD may cause damage to it.
- ✍ Insert the CI-Card in the direction marked on it.
- ✍ The place of the **COMMON INTERFACE** Slot may be different depending on its model.
- ✍ CAM is not supported in some countries and regions, check with your authorized dealer.

⑪ EX-LINK

Connector for service only.













Viewing the Remote Control

- ☑ You can use the remote control up to a distance of about 23 feet from the TV.
- ☑ The performance of the remote control may be affected by bright light.
- ☑ The product colour and shape may vary depending on the model.

- 1 **POWER** : Turns the TV on and off.
- 2 **TV** : Selects the TV mode directly.
- 3 **NUMERIC BUTTONS** : Press to change the channel.
- 4  : Performs the same function as the **ENTER**  button of the directional buttons. When switching channels with the numeric buttons, and you press the channel number and then the **ENTER**  button, the channel is immediately switched.
- 5 **CH LIST** : Used to display Channel Lists on the screen.
- 6 **TOOLS** : Use to quickly select frequently used functions.
- 7 **INFO** : Press to display information on the TV screen.
- 8 **COLOURS BUTTONS** : Use these buttons in the **Channel list**, **Media Play** menu, etc.
- 9  : Press to increase or decrease the volume.
- 10 **MUTE**  : Press to temporarily cut off the sound.
- 12 **DUAL** : Sound effect selection.
- 13 Use these buttons in the **Media Play** and **Anynet+** modes. (): This remote can be used to control recording on Samsung recorders with the Anynet+ feature)
- 14 **ON/OFF**  : Pressing the **ON/OFF**  light button toggles between on and off. When the remote control is on, and a button is pressed on the remote control, the remote control buttons will be lit for a moment. (Using the remote control with the **ON/OFF**  light button set to On will reduce the battery usage time.)

- 15 **PRE-CH** : Enables you to return to the previous channel you were watching.
- 16 **MENU** : Displays the main on-screen menu.
- 17 **FAV.CH** : Used to display Favourites Channel Lists on the screen.
- 18 **RETURN** : Returns to the previous menu
- 19 **UP ▲ / DOWN ▼ / LEFT ◀ / RIGHT ▶ / ENTER**  : Use to select on-screen menu items and change menu values.
- 20 **EXIT** : Press to exit the menu.
- 21 **SOURCE** : Press to display and select the available video sources.
- 22 **VP ▲** : Press to change channels.
- 23 **MEDIA.P** : Allows you to play music files and pictures.
- 24 **P.SIZE** : Picture size selection.
- 25 **SUBT.** : Digital subtitle display
- 26 **GUIDE** : Electronic Programme Guide (EPG) display

Teletext Functions

- 2  : Exit from the Teletext display
- 5  : Teletext store
- 6  : Teletext size selection
- 7  : Teletext reveal
- 8  : Fasttext topic selection
- 10  : Teletext mode selection (LIST / FLOF)
- 11  : Alternately select Teletext, Double, or Mix.
- 15  : Teletext sub page
- 16  : Teletext index
- 18  : Teletext hold
- 20  : Teletext cancel
- 22  : Teletext next page
-  : Teletext previous page

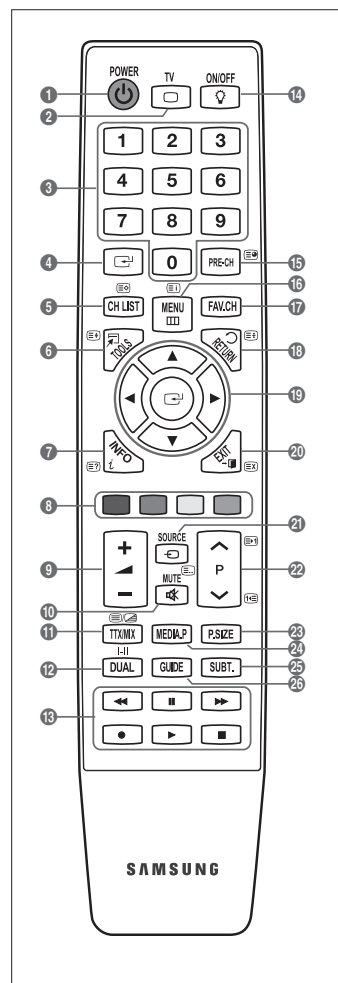

Installing Batteries in the Remote Control

Normal Remote Control

1. Lift the cover at the back of the remote control upward as shown in the figure.
2. Install two AAA size batteries.
 - Make sure to match the '+' and '-' ends of the batteries with the diagram inside the compartment.
3. Replace the cover.
 - Remove the batteries and store them in a cool, dry place if you won't be using the remote control for a long time. (Assuming typical TV usage, the batteries should last for about one year.)
 - If the remote control doesn't work, check the following:
 - Is the TV power on?
 - Are the plus and minus ends of the batteries reversed?
 - Are the batteries drained?
 - Is there a power outage or is the power cord unplugged?
 - Is there a special fluorescent light or neon sign nearby?RATI

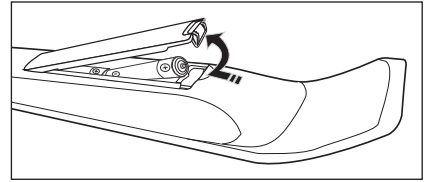

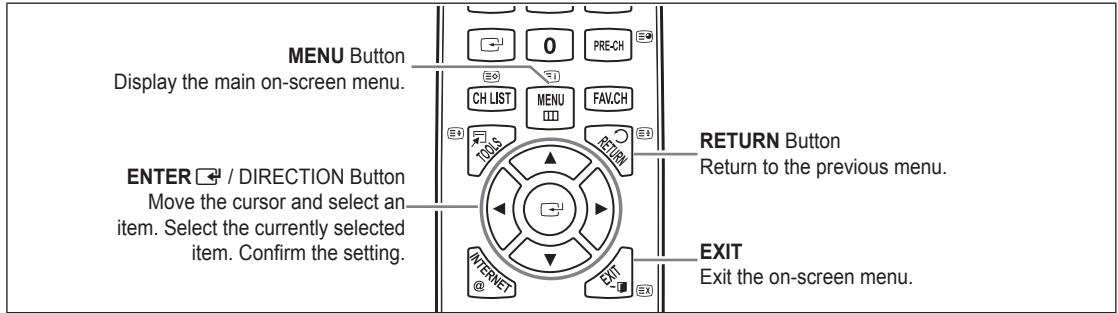

Viewing the menus

Before using the TV, follow the steps below to learn how to navigate the menu in order to select and adjust different functions.



□ Operation of the OSD (On Screen Display)

The access steps may differ depending on the selected menu.

1. Press the **MENU** button.
2. The main menu appears on the screen. The menu's left side has icons : **Picture, Sound, Channel, Setup, Input, Application, Support**.
3. Press the **▲** or **▼** button to select one of the icons.
4. Then press the **ENTER ** button to access the icon's sub-menu.
5. Press the **▲** or **▼** button to select the icon's submenu.
6. Press the **◀** or **▶** button to decrease or increase the value of a particular item. The adjustment OSD may differ depending on the selected menu.
7. Press the **ENTER ** button to complete the configuration. Press the **EXIT** button to exit.

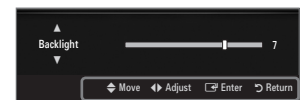
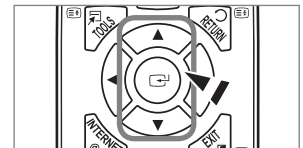
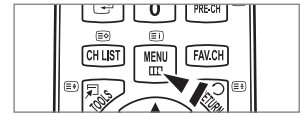

Help icon

Plug & Play Feature

When the TV is initially powered on, basic settings proceed automatically and subsequently.

1. Press the **POWER** button on the remote control.
 - ☞ You can also use the **POWER** button on the TV.
 - ☞ The message **Select the OSD Language.** is displayed.
2. Press the **ENTER** button. Select the appropriate language by pressing the **▲** or **▼** button. Press the **ENTER** button to confirm your choice.
3. Press the **◀** or **▶** button to select **Store Demo** or **Home Use**, then the **ENTER** button.
 - ☞ We recommend setting the TV to **Home Use** mode for the best picture in your home environment.
 - ☞ **Store Demo** mode is only intended for use in retail environments.
 - ☞ If the unit is accidentally set to **Store Demo** mode and you want to return to **Home Use (Standard)**: Press the volume button on the TV. When the volume OSD is displayed, press and hold the **MENU** button on the TV for 5 seconds.
4. Press the **ENTER** button. Select the appropriate country by pressing the **▲** or **▼** button. Press the **ENTER** button to confirm your choice.
5. Press the **▲** or **▼** button to select **Air** or **Cable**, then press the **ENTER** button.
 - ☞ **Air**: Air antenna signal.
 - ☞ **Cable**: Cable antenna signal.
6. Press the **▲** or **▼** button to select the channel source to memorize. Press the **ENTER** button to select **Start**.
 - ☞ When setting the antenna source to **Cable**, a step appears allowing you to set a value for the digital channel search. For more information, refer to **Channel → Auto Store**.
 - ☞ **Digital & Analogue**: Digital and Analogue channels.
 - Digital**: Digital channels.
 - Analogue**: Analogue channels.
 - ☞ The channel search will start and end automatically.
 - ☞ Press the **ENTER** button at any time to interrupt the memorization process.
 - ☞ After all the available channels are stored, the message **Set the Clock Mode.** is displayed.
7. Press the **ENTER** button. Press the **▲** or **▼** button to select **Auto**, then Press the **ENTER** button.
 - ☞ If you select **Manual**, **Set current date and time** is displayed.
 - ☞ If you have received a digital signal, the time will be set automatically. If not, select **Manual** to set the clock.
8. The description for the connection method providing the best HD screen quality is displayed. Check the description and press the **ENTER** button.
9. The message **Enjoy your viewing** is displayed. When you have finished, press the **ENTER** button.

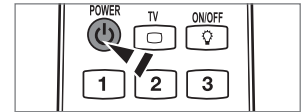

If you want to reset this feature...

1. Press the **MENU** button to display the menu. Press the **▲** or **▼** button to select **Setup**, then press the **ENTER** button.
2. Press the **ENTER** button again to select **Plug & Play**.
3. Enter your 4 digit PIN number. The default PIN number of a new TV set is '0-0-0-0'.
 - ☞ If you want to change PIN number, use the **Change PIN** function.
 - ☞ The **Plug & Play** feature is only available in the TV mode.

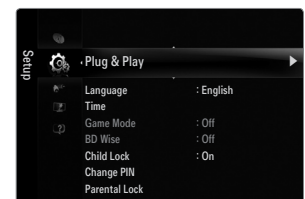

CHANNEL

Channel Menu

□ Country

■ Analogue Channel

You can change the country for analogue channels.

■ Digital Channel

You can change the country for digital channels.

The PIN number input screen appears. Enter your 4 digit PIN number.

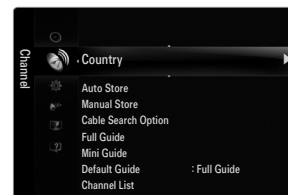

□ Auto Store

You can scan for the frequency ranges available to you (and availability depends on your country). Automatically allocated programme numbers may not correspond to actual or desired programme numbers.

If a channel is locked using the **Child Lock** function, the PIN input window appears.

■ Air / Cable

Antenna source to memorize

- **Digital & Analogue:** Digital and Analogue channels.
- **Digital:** Digital channels.
- **Analogue:** Analogue channels.

When selecting Cable → Digital & Analogue or Cable → Digital:

Provide a value to scan for cable channels.

- **Search Mode** → Full / Network / Quick

Quick

- **Network ID:** Displays the network identification code.
- **Frequency:** Displays the frequency for the channel. (Differs in each country)
- **Modulation:** Displays available modulation values.
- **Symbol Rate:** Displays available symbol rates.

Scans for all channels with active broadcast stations and stores them in the TV's memory.

If you want to stop Auto Store, press the **ENTER**  button.

The **Stop Auto Store?** message will be displayed.

Select **Yes** by pressing the ◀ or ▶ button, then press the **ENTER**  button.

□ Manual Store

Scans for a channel manually and stores it in the TV's memory.

If a channel is locked using the **Child Lock** function, the PIN input window appears.

■ Digital Channel

Manual store for digital channels.

Digital Channel is only available in DTV mode.

- **Channel:** Set the Channel number using the ▲, ▼ or number (0~9) buttons.
- **Frequency:** Set the frequency using the number buttons.
- **Bandwidth:** Set the bandwidth using the ▲, ▼ or number (0~9) buttons.

When it has finished, channels are updated in the channel list.

■ Analogue Channel

Manual store for analogue channel.

- **Programme** (Programme number to be assigned to a channel): Sets the programme number using the ▲, ▼ or number (0~9) buttons.
- **Colour System** → Auto / PAL / SECAM / NTSC4.43: Sets the colour system value using the ▲ or ▼ button.
- **Sound System** → BG / DK / I / L: Sets the sound system value using the ▲ or ▼ button.

- **Channel** (When you know the number of the channel to be stored): Press the ▲ or ▼ button to select **C** (Air channel) or **S** (Cable channel). Press the ► button, then press the ▲, ▼ or number (0~9) buttons to select the required number.
 - 📌 You can also select the channel number directly by pressing the number (0~9) buttons.
 - 📌 If there is abnormal sound or no sound, reselect the sound standard required.
 - 📌 **Search** (When you do not know the channel numbers): Press the ▲ or ▼ button to start the search. The tuner scans the frequency range until the first channel or the channel that you selected is received on the screen.
- **Store** (When you store the channel and associated programme number): Set to **OK** by pressing the **ENTER**  button.
 - 📌 Channel mode
 - P (Programme mode): When completing tuning, the broadcasting stations in your area have been assigned to position numbers from P00 to P99. You can select a channel by entering the position number in this mode.
 - C (Air channel mode): You can select a channel by entering the assigned number to each air broadcasting station in this mode.
 - S (Cable channel mode): You can select a channel by entering the assigned number for each cable channel in this mode.

❑ Cable Search Option (depending on the country)

Using this function, you can manually add the channel range to be scanned by Full Search mode of the Auto Store function.

- **Freq.Start** (Frequency Start): Set the start frequency (Differs in each country)
- **Freq.Stop** (Frequency Stop): Set the stop frequency (Differs in each country)
- **Modulation**: Displays available modulation values.
- **Symbol Rate**: Displays available symbol rates.

❑ Full Guide / Mini Guide

The EPG (Electronic Programme Guide) information is provided by the broadcasters. Programme entries may appear blank or out of date as a result of the information broadcast on a given channel. The display will dynamically update as soon as new information becomes available.

 You can also display the guide menu simply by pressing the **GUIDE** button. (To configure the **Default Guide**, refer to the descriptions.)

■ Full Guide

Displays the programme information as time ordered One hour segments. Two hours of programme information is displayed which may be scrolled forwards or backwards in time.

■ Mini Guide

The information of each programme is displayed by each line on the current channel Mini Guide screen from the current programme onwards according to the programme starting time order.

❑ Default Guide → Mini Guide / Full Guide

You can decide whether to display either the **Mini Guide** or the **Full Guide** when the **GUIDE** button on the remote control is pressed.

❑ Channel List

For detailed procedures on using the **Channel List**, refer to the **Managing Channels** instructions.

 You can select these options by simply pressing the **CH LIST** button on the remote control.

❑ Channel Mode

When press the P  /  button, Channels will be switched within the selected channel list.

■ Added Ch.

Channels will be switched within the memorized channel list.

■ Favourite Ch.

Channels will be switched within the favourite channel list.

❑ Fine Tune

If the reception is clear, you do not have to fine tune the channel, as this is done automatically during the search and store operation. If the signal is weak or distorted, you may have to fine tune the channel manually.

- ☑ Fine tuned channels that have been saved are marked with an asterisk "*" on the right-hand side of the channel number in the channel banner.
- ☑ To reset the fine-tuning, select **Reset** by pressing the ▲ or ▼ button and then press the **ENTER** button.
- ☑ Only Analogue TV channels can be fine tuned.

Using the Full / Mini Guide



To...	Then...
Watch a programme in the EPG list	Select a programme by pressing the ▲, ▼, ◀, ▶ button.
Exit the guide	Press the blue button
If the next programme is selected, it is scheduled with the clock icon displayed. If the ENTER button is pressed again, press the ◀, ▶ button to select Cancel Schedules , the scheduling is cancelled with the clock icon gone.	
View programme information	Select a programme of your choice by pressing the ▲, ▼, ◀, ▶ button. Then press the INFO button when the programme of your choice is highlighted. The programme title is on the upper part of the screen centre.
Please click on INFO button for the detailed information. Channel Number, Running Time, Status Bar, Parental Level, Video Quality Information (HD / SD), Sound Modes, Subtitle or Teletext, languages of Subtitle or Teletext and brief summary of the highlighted programme are included on the detailed information. "... " will be appeared if the summary is long.	
Toggle between the Mini Guide and Full Guide	Press the Red button repeatedly.
In Full Guide	
Scrolls backwards quickly (24 hours).	Press the Green button repeatedly.
Scrolls forwards quickly (24 hours).	Press the Yellow button repeatedly.
In Mini Guide	
Display previous page quickly.	Press the Green button.
Display next page quickly.	Press the Yellow button.

Managing Channels

Using this menu, you can add / delete or set favourites channels and use the programme guide for digital broadcasts.



All Channels

Shows all currently available channels.

Added Channels

Shows all added channels.

Favourites

Shows all favourite channels.

To select the favourites channels you have set up, press the **FAV.CH** button on the remote control.

Programmed

Shows all current reserved programmes.

Select a channel in the **All Channels**, **Added Channels** or **Favourites** screen by pressing the **▲ / ▼** buttons, and pressing the **ENTER** button. Then you can watch the selected channel.

Using the Colour buttons with the Channel List

- Red (**Channel Type**): Toggle between your **TV, Radio, Data / Other** and **All**.
- Green (**Zoom**): Enlarges or shrinks a channel number.
- Yellow (**Select**): Selects multiple channel lists. You can perform the add/delete or add to favourites/delete from favourites function for multiple channels at the same time. Select the required channels and press the Yellow button to set all the selected channels at the same time. The mark appears to the left of the selected channels.
- **TOOLS (Tools)**: Displays the **Delete** (or **Add**), **Add to Favourite** (or **Delete from Favourite**), **Lock** (or **Unlock**), **Timer Viewing**, **Edit Channel Name**, **Edit Channel Number**, **Sort**, **Select All**, **Deselect All** or **Auto Store** menu. (The Options menus may differ depending on the situation.)

Channel Status Display Icons

- : An Analogue channel.
- : A channel selected by pressing the Yellow button.
- : A channel set as a Favourite.
- : A programme currently being broadcast.
- : A locked channel.
- : A reserved programme

Channel List Option Menu (in All Channels / Added Channels / Favourites)

Press the **TOOLS** button to use the option menu.

Option menu items may differ depending on the channel status.

Add / Delete

You can delete or add a channel to display the channels you want.

All deleted channels will be shown on **All Channels** menu.

A gray-coloured channel indicates the channel has been deleted.

The **Add** menu only appears for deleted channels.

You can also delete a channel to the **Added Channels** or **Favourites** menu in the same manner.



Add to Favourite / Delete from Favourite

You can set channels you watch frequently as favourites.

Press the **TOOLS** button to display the **Tools** menu. You can also set the add to (or delete from) Favourite by selecting **Tools** → **Add to Favourite** (or **Delete from Favourite**).

The symbol will be displayed and the channel will be set as a favourite.

All favourite channels will be shown on **Favourites** menu.

Lock / Unlock

You can lock a channel so that the channel cannot be selected and viewed.

This function is available only when the **Child Lock** is set to **On**.

The PIN number input screen appears. Enter your 4 digit PIN number.

The default PIN number of a new TV set is '0-0-0-0'. You can change the PIN, by selecting **Change PIN** from the menu.

The symbol will be displayed and the channel will be locked.

■ **Timer Viewing**

If you reserve a programme you want to watch, the channel is automatically switched to the reserved channel in the Channel List; even when you are watching another channel. To reserve a programme, set the current time first.

- ☑ Only memorized channels can be reserved.
- ☑ You can set the channel, day, month, year, hour and minute directly by pressing the number buttons on the remote control.
- ☑ Reserving a programme will be shown in the **Programmed** menu.
- ☑ Digital Programme Guide and Viewing Reservation
When a digital channel is selected, and you press the ► button, the Programme Guide for the channel appears. You can reserve a programme according to the procedures described above.

■ **Edit Channel Name (analogue channels only)**

Channels can be labelled so that their call letters appear whenever the channel is selected.

- ☑ The names of digital broadcasting channels are automatically assigned and cannot be renamed.

■ **Edit Channel Number (digital channels only)**

You can also edit the channel number by pressing the number buttons on the remote control.

■ **Sort (analogue channels only)**

This operation allows you to change the programme numbers of the stored channels. This operation may be necessary after using the auto store.

■ **Select All / Deselect All**

- **Select All:** You can select all the channels in the channel list.
- **Deselect All:** You can deselect all the selected channels.
- ☑ You can only select **Deselect All** when there is a selected channel.

■ **Auto Store**

- ☑ For detailed procedures on setting up options, refer to the 'Channel Menu' instructions.
- ☑ If a channel is locked using the **Child Lock** function, the PIN input window appears.

Channel List Option Menu (in Programmed)

You can view, modify or delete a reservation.

- ☑ Press the **TOOLS** button to use the option menu.

■ **Change Info**

Select to change a viewing reservation.

■ **Cancel Schedules**

Select to cancel a viewing reservation.

■ **Information**

Select to view a viewing reservation.
(You can also change the reservation information.)

■ **Select All**

Select all reserved programmes.



PICTURE

Configuring the Picture Menu

□ Mode

You can select the type of picture which best corresponds to your viewing requirements.

✎ Press the **TOOLS** button to display the **Tools** menu. You can also set the picture mode by selecting **Tools** → **Picture Mode**.

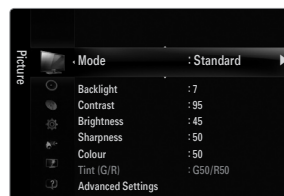

■ Dynamic

Selects the picture for increased definition in a bright room.

■ Standard

Selects the picture for the optimum display in a normal environment.

■ Natural

Selects the picture for an optimum and eye-comfortable display.

■ Movie

Selects the picture for viewing movies in a dark room.

□ Backlight / Contrast / Brightness / Sharpness / Colour / Tint(G/R)

Your television has several setting options that allow you to control the picture quality.

- **Backlight:** Adjusts the brightness of LED back light.
 - **Contrast:** Adjusts the contrast level of the picture.
 - **Brightness:** Adjusts the brightness level of the picture
 - **Sharpness:** Adjusts the edge definition of the picture.
 - **Colour:** Adjusts colour saturation of the picture.
 - **Tint(G/R):** Adjusts the colour tint of the picture.
- ✎ In analogue **TV, Ext., AV** modes of the PAL system, you cannot use the **Tint(G/R)** Function.
- ✎ When you make changes to **Backlight, Contrast, Brightness, Sharpness, Colour** or **Tint(G/R)** the OSD will be adjusted accordingly.
- ✎ In PC mode, you can only make changes to **Backlight, Contrast** and **Brightness**.
- ✎ Settings can be adjusted and stored for each external device you have connected to an input of the TV.
- ✎ The energy consumed during use can be significantly reduced if the brightness level of the picture is lowered, which will reduce the overall running cost.

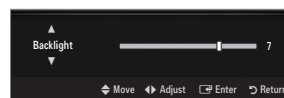

❑ Advanced Settings

Samsung's new TVs allow you to make even more precise picture settings than previous models.

- ✔ **Advanced Settings** is available in **Standard** or **Movie** mode.
- ✔ In PC mode, you can only make changes to **Dynamic Contrast**, **Gamma** and **White Balance** from among the **Advanced Settings** items.

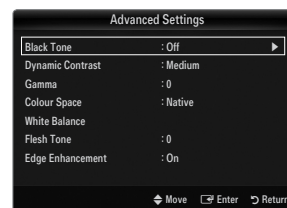

■ Black Tone → Off / Dark / Darker / Darkest

You can select the black level on the screen to adjust the screen depth.

■ Dynamic Contrast → Off / Low / Medium / High

You can adjust the screen contrast so that the optimal contrast is provided.

■ Gamma

You can adjust the primary colour (red, green, blue) intensity.

■ Colour Space

Colour space is a colour matrix composed of red, green and blue colours. Select your favourites colour space to experience the most natural colour.

- **Auto:** Auto Colour Space automatically adjusts to the most natural colour tone based on programme sources.
- **Native:** Native Colour Space offers deep and rich colour tone.
- **Custom:** Adjusts the colour range to suit your preference.
 - ✔ Changing the adjustment value will refresh the adjusted screen.
 - ✔ Settings can be adjusted and stored for each external device you have connected to an input of the TV. For example, if you have a DVD player connected to HDMI 1 and it is currently selected, settings and adjustments will be saved for the DVD player.
 - **Colour: Red, Green, Blue, Yellow, Cyan or Magenta**
 - ✔ **Colour** is available when **Colour Space** is set to **Custom**.
 - ✔ In **Colour**, you can adjust the RGB values for the selected colour.
 - ✔ To reset the adjusted RGB value, select **Reset**.
 - **Red:** Adjusts the red saturation level of the selected colour.
 - **Green:** Adjusts the green saturation level of the selected colour.
 - **Blue:** Adjusts the blue saturation level of the selected colour.
 - **Reset:** Resets the colour space to the default values.

■ White Balance

You can adjust the colour temperature for more natural picture colours.

- **R-Offset:** Adjusts the red colour darkness.
- **G-Offset:** Adjusts the green colour darkness.
- **B-Offset:** Adjusts the blue colour darkness.
- **R-Gain:** Adjusts the red colour brightness.
- **G-Gain:** Adjusts the green colour brightness.
- **B-Gain:** Adjusts the blue colour brightness.
- **Reset:** The previously adjusted white balance will be reset to the factory defaults.

■ Flesh Tone

You can emphasize the pink 'flesh tone' in the picture.

- ✔ Changing the adjustment value will refresh the adjusted screen.

■ Edge Enhancement → Off / On

You can emphasize object boundaries in the picture.

■ xvYCC → Off / On

Setting the xvYCC mode to on increases detail and colour space when watching movies from an external device (ie. DVD player) connected to the HDMI or Component IN jacks.

- ✔ **xvYCC** is available when the picture mode is set to **Movie**, and the external input is set to HDMI or Component mode.

□ Picture Options

- ☑ In PC mode, you can only make changes to the **Colour Tone** and **Size** from among the items in **Picture Options**.

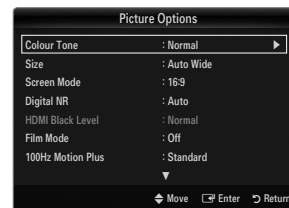

■ Colour Tone → Cool / Normal / Warm1 / Warm2 / Warm3

- ☑ **Warm1**, **Warm2** or **Warm3** is only activated when the picture mode is **Movie**.
- ☑ Settings can be adjusted and stored for each external device you have connected to an input of the TV.

■ Size

Occasionally, you may want to change the size of the image on your screen. Your TV comes with several screen size options, each designed to work best with specific types of video input. Your cable box/satellite receiver may have its own set of screen sizes as well. In general, though, you should view the TV in 16:9 mode as much as possible.

☑ You can select these options by simply pressing the **P.SIZE** button on the remote control.

- **Auto Wide**: Automatically adjusts the picture size to the **16:9** aspect ratio.
- **16:9**: Adjusts the picture size to 16:9 appropriate for DVDs or wide broadcasting.
- **Wide Zoom**: Magnify the size of the picture more than 4:3.
- **Zoom**: Magnifies the 16:9 wide picture (in the vertical direction) to fit the screen size.
- **4:3**: This is the default setting for a video movie or normal broadcasting.
- **Screen Fit**: Use the function to see the full image without any cut-off when HDMI (720p / 1080i / 1080p) or Component (1080i / 1080p) signals are input.

☑ Depending on the input source, the picture size options may vary.

☑ The items available may differ depending on the selected mode.

☑ In PC Mode, only **16:9** and **4:3** mode can be adjusted.

☑ Settings can be adjusted and stored for each external device you have connected to an input of the TV.

☑ Temporary image retention may occur when viewing a static image on the set for more than two hours.

☑ **Wide Zoom**: Press the **▶** button to Select **Position**, then press the **ENTER** button. Press the **▲** or **▼** button to move the picture up / down. Then press the **ENTER** button.

☑ **Zoom**: Press the **▶** button to Select **Position**, then press the **ENTER** button. Press the **▲** or **▼** button to move the picture up and down. Then press the **ENTER** button. Press the **▶** button to Select **Size**, then press the **ENTER** button. Press the **▲** or **▼** button to magnify or reduce the picture size in the vertical direction. Then press the **ENTER** button.

☑ After selecting **Screen Fit** in **HDMI** (1080i / 1080p) or **Component** (1080i / 1080p) mode: Select **Position** by pressing the **◀** or **▶** button. Use the **▲**, **▼**, **◀** or **▶** button to move the picture.

– **Reset**: Press the **◀** or **▶** button to select **Reset**, then press the **ENTER** button. You can initialize the setting.

☑ If you use the **Screen Fit** function with HDMI 720p input, 1 line will be cut at the top, bottom, left and right as in the Overscan function.

■ Screen Mode → 16:9 / Wide Zoom / Zoom / 4:3

When setting the picture size to **Auto Wide** in a 16:9 wide TV, you can determine the picture size you want to see the 4:3 WSS (Wide Screen Service) image or nothing. Each individual European country requires different picture size so this function is intended for users to select it.

- **16:9**: Sets the picture to 16:9 wide mode.
- **Wide Zoom**: Magnify the size of the picture more than 4:3.
- **Zoom**: Magnify the size of the picture vertically on screen.
- **4:3**: Sets the picture to 4:3 normal mode.

☑ This function is available in **Auto Wide** mode.

☑ This function is not available in PC, Component or HDMI mode.

■ Digital NR → Off / Low / Medium / High / Auto

If the broadcast signal received by your TV is weak, you can activate the Digital Noise Reduction feature to help reduce any static and ghosting that may appear on the screen.

☑ When the signal is weak, select one of the other options until the best picture is displayed.

■ HDMI Black Level → Normal / Low

You can select the black level on the screen to adjust the screen depth.

☑ This function is active only when an external device is connected to the TV via HDMI (RGB signals).

■ **Film Mode** → **Off / Auto1 / Auto2**

The TV can be set to automatically sense and process film signals from all sources and adjust the picture for optimum quality.

Film Mode is supported in TV, AV, COMPONENT(480i / 1080i) and HDMI(480i / 1080i).

- **Off:** Turn the Film Mode function off.
- **Auto1:** Automatically adjusts the picture for the best quality when watching a film.
- **Auto2:** Automatically optimizes the video text on the screen (not including closed captions) when watching a film.

■ **100Hz Motion Plus** → **Off / Clear / Standard / Smooth / Custom / Demo**

Removes drag from fast scenes with a lot of movement to provide a clearer picture.

If you enable **100 Hz Motion Plus**, noise may appear on the screen. If this occurs, set **100Hz Motion Plus** to **Off**.

- **Off:** Switches 100Hz Motion Plus off.
- **Clear:** Sets 100Hz Motion Plus to minimum.
- **Standard:** Sets 100Hz Motion Plus to medium.
- **Smooth:** Sets 100Hz Motion Plus to maximum.
- **Custom:** Adjusts the blur and judder reduction level to suit your preference.
 - **Blur Reduction:** Adjusts the blur reduction level from video sources.
 - **Judder Reduction:** Adjusts the judder reduction level from video sources when playing films.
 - **Reset:** Reset the custom settings.
- **Demo:** Displays the difference between 100Hz Motion Plus on and off modes.

■ **Blue Only Mode** → **Off / On**

This function is for AV device measurement experts. This function displays the blue signal only by removing the red and green signals from the video signal so as to provide a Blue Filter effect that is used to adjust the Colour and Tint of video equipment such as DVD players, Home Theatres, etc. Using this function, you can adjust the Colour and Tint to preferred values appropriate to the signal level of each video device using the Red / Green / Blue / Cyan / Magenta / Yellow Colour Bar Patterns, without using an additional Blue Filter.

Blue Only Mode is available when the picture mode is set to **Movie** or **Standard**.

□ **Picture Reset** → **Reset Picture Mode / Cancel**

Resets all picture settings to the default values.

Reset Picture Mode: Current picture values return to default settings.

Using Your TV as a Computer (PC) Display

Setting Up Your PC Software (Based on Windows XP)

The Windows display-settings for a typical computer are shown below. The actual screens on your PC will probably be different, depending upon your particular version of Windows and your particular video card. However, even if your actual screens look different, the same basic set-up information will apply in almost all cases. (If not, contact your computer manufacturer or Samsung Dealer.)

1. First, click on 'Control Panel' on the Windows start menu.
2. When the control panel window appears, click on 'Appearance and Themes' and a display dialog-box will appear.
3. When the control panel window appears, click on 'Display' and a display dialogbox will appear.
4. Navigate to the 'Settings' tab on the display dialog-box.
 - The correct size setting (resolution) - Optimum: 1920 X 1080 pixels
 - If a vertical-frequency option exists on your display settings dialog box, the correct value is '60' or '60 Hz'. Otherwise, just click 'OK' and exit the dialog box.

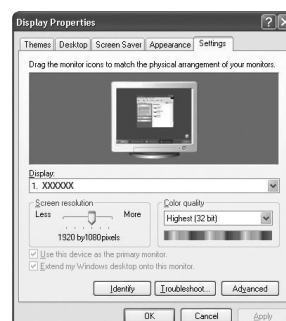

Display Modes

If the signal from the system equals the standard signal mode, the screen is adjusted automatically. If the signal from the system doesn't equal the standard signal mode, adjust the mode by referring to your videocard user guide; otherwise there may be no video. For the display modes listed on the next page, the screen image has been optimized during manufacturing.

D-Sub and HDMI/DVI Input

Mode	Resolution	Horizontal Frequency (KHz)	Vertical Frequency (Hz)	Pixel Clock Frequency (MHz)	Sync Polarity (H / V)
IBM	640 x 350	31.469	70.086	25.175	+/-
	720 x 400	31.469	70.087	28.322	-/+
MAC	640 x 480	35.000	66.667	30.240	-/-
	832 x 624	49.726	74.551	57.284	-/-
	1152 x 870	68.681	75.062	100.000	-/-
VESA CVT	720 x 576	35.910	59.950	32.750	-/+
	1152 x 864	53.783	59.959	81.750	-/+
	1280 x 720	44.772	59.855	74.500	-/+
	1280 x 720	56.456	74.777	95.750	-/+
	1280 x 960	75.231	74.857	130.000	-/+
VESA DMT	640 x 480	31.469	59.940	25.175	-/-
	640 x 480	37.861	72.809	31.500	-/-
	640 x 480	37.500	75.000	31.500	-/-
	800 x 600	37.879	60.317	40.000	+/+
	800 x 600	48.077	72.188	50.000	+/+
	800 x 600	46.875	75.000	49.500	+/+
	1024 x 768	48.363	60.004	65.000	-/-
	1024 x 768	56.476	70.069	75.000	-/-
	1024 x 768	60.023	75.029	78.750	+/+
	1152 x 864	67.500	75.000	108.000	+/+
	1280 x 1024	63.981	60.020	108.000	+/+
	1280 x 1024	79.976	75.025	135.000	+/+
	1280 x 800	49.702	59.810	83.500	-/+
	1280 x 800	62.795	74.934	106.500	-/+
	1280 x 960	60.000	60.000	108.000	+/+
1360 x 768	47.712	60.015	85.500	+/+	
1440 x 900	55.935	59.887	106.500	-/+	
1440 x 900	70.635	74.984	136.750	-/+	
1680 x 1050	65.290	59.954	146.250	-/+	
VESA GTF	1280 x 720	52.500	70.000	89.040	-/+
	1280 x 1024	74.620	70.000	128.943	-/-
VESA DMT / DTV CEA	1920 x 1080p	67.500	60.000	148.500	+/+

- ☑ When using an HDMI / DVI cable connection, you must use the **HDMI IN 1(DVI)** jack.
- ☑ The interface mode is not supported.
- ☑ The set might operate abnormally if a non-standard video format is selected.
- ☑ Separate and Composite modes are supported. SOG is not supported.
- ☑ Too long or low quality VGA cable can cause picture noise at high resolution modes (1920x1080).

Setting up the TV with your PC

 Preset: Press the **SOURCE** button to select PC mode.

□ Auto Adjustment

Use the Auto Adjust function to have the TV automatically adjust the video signals it receives. The function also automatically fine-tunes the settings and adjusts the frequency values and positions.

 Press the **TOOLS** button to display the **Tools** menu. You can also set the Auto Adjustment by selecting **Tools** → **Auto Adjustment**.

 This function does not work in DVI-HDMI mode.

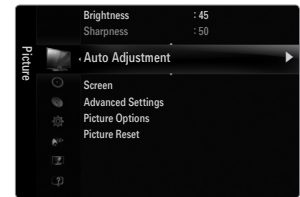

□ Screen

■ Coarse / Fine

The purpose of picture quality adjustment is to remove or reduce picture noise. If the noise is not removed by Fine-tuning alone, then adjust the frequency as best as possible (**Coarse**) and Fine-tune again. After the noise has been reduced, readjust the picture so that it is aligned on the centre of screen.

■ PC Position

Adjust the PC's screen positioning if it does not fit the TV screen.

Press the **▲** or **▼** button to adjusting the Vertical-Position. Press the **◀** or **▶** button to adjust the Horizontal-Position.

■ Image Reset

You can replace all image settings with the factory default values.

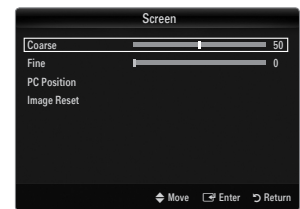

Configuring the Sound Menu

□ Mode → Standard / Music / Movie / Clear Voice / Custom

 Press the **TOOLS** button to display the **Tools** menu. You can also set the sound mode by selecting **Tools** → **Sound Mode**.

- **Standard:** Selects the normal sound mode.
- **Music:** Emphasizes music over voices.
- **Movie:** Provides the best sound for movies.
- **Clear Voice:** Emphasizes voice over other sounds.
- **Custom:** Recalls your customized sound settings.

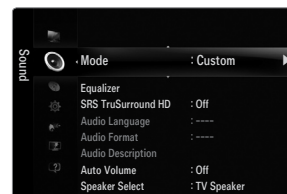

□ Equalizer

The sound settings can be adjusted to suit your personal preferences.

- **Mode:** Selects the sound mode among the predefined settings.
- **Balance L/R:** Adjusts the balance between the right and left speaker.
- **100Hz / 300Hz / 1KHz / 3KHz / 10KHz (Bandwidth Adjustment):** To adjust the level of different bandwidth frequencies.
- **Reset:** Resets the equalizer settings to the default values.

□ SRS TruSurround HD → Off / On

SRS TruSurround HD is a patented SRS technology that solves the problem of playing 5.1 multichannel content over two speakers. TruSurround delivers a compelling, virtual surround sound experience through any two-speaker playback system, including internal television speakers. It is fully compatible with all multichannel formats.

 Press the **TOOLS** button to display the **Tools** menu. You can also set the SRS TruSurround HD by selecting **Tools** → **SRS TS HD**.

□ Audio Language

You can change the default value for audio languages. Displays the language information for the incoming stream.

- While viewing a digital channel, this function can be selected.
- You can only select the language among the actual languages being broadcast.

□ Audio Format → MPEG / Dolby Digital

When sound is emitted from both the main speaker and the audio receiver, a sound echo may occur due to the decoding speed difference between the main speaker and the audio receiver. In this case, use the TV Speaker function.

- While viewing a digital channel, this function can be selected.
- The Audio Format appears according to the broadcasting signal.

□ Audio Description

This is an auxiliary audio function that provides an additional audio track for visually challenged persons. This function handles the Audio Stream for the AD (Audio Description), when it is sent along with the Main audio from the broadcaster. Users can turn the Audio Description On or Off and control the volume.

■ Audio Description → Off / On

Turn the audio description function on or off.

■ Volume

You can adjust the audio description volume.

- Volume** is active when **Audio Description** is set to **On**.
- While viewing a Digital channel, this function can be selected.

□ Auto Volume → Off / On

Each broadcasting station has its own signal conditions, and so it is not easy to adjust the volume every time the channel is changed. This feature lets you automatically adjust the volume of the desired channel by lowering the sound output when the modulation signal is high or by raising the sound output when the modulation signal is low.

□ Speaker Select

When you watch TV with it connecting to a Home theatre, turn the TV speakers off so you can listen to sound from the Home theatre's (external) speakers.

- **External Speaker:** Used to listen to the sound of the External (Home Theatre) Speakers.
 - **TV Speaker:** Used to listen to the sound of the TV Speakers.
- ☑ The volume and **MUTE** buttons do not operate when the **Speaker Select** is set to **External Speaker**.
- ☑ If you select **External Speaker** in the **Speaker Select** menu, the sound settings will be limited

	TV's Internal Speakers	Audio Out (Optical) to Sound System
	RF / AV / Component / PC / HDMI	RF / AV / Component / PC / HDMI
TV Speaker	Speaker Output	Sound Output
External Speaker	Mute	Sound Output
Video No Signal	Mute	Mute

□ Sound Reset → Reset All / Reset Sound Mode / Cancel

You can restore the Sound settings to the factory defaults.

- ☑ **Reset Sound Mode:** Current sound values return to default settings.

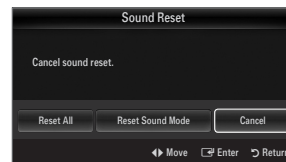

Selecting the Sound Mode

You can set the sound mode by pressing the **DUAL** button. When you press it, the current sound mode is displayed on the screen.

	Audio Type	Dual 1 / 2	Default
A2 Stereo	Mono	MONO	Automatic change
	Stereo	STEREO ↔ MONO	
	Dual	DUAL 1 ↔ DUAL 2	DUAL 1
NICAM Stereo	Mono	MONO	Automatic change
	Stereo	MONO ↔ STEREO	
	Dual	MONO ↔ DUAL 1 DUAL 2	DUAL 1

- ☑ If the stereo signal is weak and an automatic switching occurs, then switch to the mono.
- ☑ This function is only activated in stereo sound signal. It is deactivated in mono sound signal.
- ☑ This function is only available in TV mode.

Configuring the Setup Menu

□ Language

You can set the menu language.

□ Time

For detailed procedures on setting up options, refer to the 'Setting the Time' instructions.

□ Game Mode → Off / On

When connecting to a game console such as PlayStation™ or Xbox™, you can enjoy a more realistic gaming experience by selecting game menu.

- ☑ Restrictions on game mode (Caution)
 - To disconnect the game console and connect another external device, set **Game Mode** to **Off** in the setup menu.
 - If you display the TV menu in **Game Mode**, the screen shakes slightly.
- ☑ **Game Mode** is not available in regular TV, PC and Ext mode.
- ☑ If the picture is poor when external device is connected to TV, check if **Game Mode** is **On**. Set **Game Mode** to **Off** and connect external devices.
- ☑ If **Game Mode** is **On**:
 - Picture mode is automatically changed to **Standard** and cannot be changed.
 - Sound mode is automatically changed to **Custom** and cannot be changed. Adjust the sound using the equalizer.
 - The Reset Sound function is activated. Selecting the Reset function after setting the equalizer resets the equalizer settings to the factory defaults.

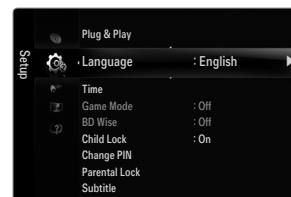

□ BD Wise → Off / On

Provides the optimal picture quality for SAMSUNG DVD, Blu-ray and Home Theatre products which support BD Wise. You can enjoy a richer picture when using them connected to this Samsung TV.

- ☑ Connect SAMSUNG products that have BD Wise using an HDMI cable.
- ☑ When the **BD Wise** set to **On**, the picture mode is automatically changed to the optimal resolution.
- ☑ **BD Wise** is available in HDMI mode.

□ Child Lock → Off / On

This feature allows you to prevent unauthorized users, such as children, from watching unsuitable programme by muting out video and audio.

- ☑ Before the setup screen appears, the PIN number input screen appears. Enter your 4 digit PIN number.
- ☑ The default PIN number of a new TV set is 0-0-0-0. You can change the PIN by selecting **Change PIN** from the menu.
- ☑ You can lock some channels in Channel List.
- ☑ **Child Lock** is available only in TV mode.

□ Change PIN

You can change your personal ID number that is required to set up the TV.

- ☑ Before the setup screen appears, the PIN number input screen appears. Enter your 4 digit PIN number.
- ☑ The default PIN number of a new TV set is 0-0-0-0.
- ☑ If you forget the PIN code, press the remote control buttons in the following sequence, which resets the PIN to 0-0-0-0: **POWER** (Off) → **MUTE** → **8** → **2** → **4** → **POWER** (On).

□ Parental Lock → Parental Rating

This feature allows you to prevent unauthorized users, such as children, from watching unsuitable programme by a 4-digit PIN (Personal Identification Number) code that is defined by the user.

- ☑ The **Parental Rating** item differs depending on the country.
- ☑ Before the setup screen appears, the PIN number input screen appears. Enter your 4 digit PIN number.
- ☑ The default PIN number of a new TV set is '0-0-0-0'. You can change the PIN by selecting **Change PIN** from the menu.
- ☑ When the parental ratings are set, the '🔒' symbol is displayed.
- ☑ **Allow All**: Press to unlock all TV ratings.
Block All: Press to lock all TV ratings.

□ Subtitle

You can activate and deactivate the subtitles. Use this menu to set the Subtitle Mode. **Normal** under the menu is the basic subtitle and **Hard of hearing** is the subtitle for a hearing-impaired person.

■ Subtitle → Off / On

Switches subtitles on or off.

■ Mode → Normal / Hard of hearing

Sets the subtitle mode.

■ Subtitle Language

Set the subtitle language.

- ☑ If the programme you are watching does not support the **Hard of hearing** function, **Normal** automatically activates even though **Hard of hearing** mode is selected.
- ☑ English is the default in cases where the selected language is unavailable in the broadcast.
- ☑ You can select these options simply by pressing the **SUBT.** button on the remote control.

□ Teletext Language

You can set the Teletext language by selecting the language type.

- ☑ English is the default in cases where the selected language is unavailable in the broadcast.

□ Preference

■ Primary Audio Language / Secondary Audio Language / Primary Subtitle Language / Secondary Subtitle Language / Primary Teletext Language / Secondary Teletext Language

Using this feature, users can select one of the languages. The language selected here is the default when the user selects a channel.

If you change the language setting, the Subtitle Language, Audio Language, and the Teletext Language of the Language menu are automatically changed to the selected language.

The Subtitle Language, Audio Language, and the Teletext Language of the Language menu show a list of languages supported by the current channel and the selection is highlighted. If you change this language setting, the new selection is only valid for the current channel. The changed setting does not change the setting of the Primary Subtitle Language, Primary Audio Language, or the Primary Teletext Language of the Preference menu.

□ Digital Text → Disable / Enable

If the programme is broadcast with digital text, this feature is enabled.

- ☑ MHEG (Multimedia and Hypermedia Information Coding Experts Group)
An International standard for data encoding systems used in multimedia and hypermedia. This is at a higher level than the MPEG system which includes data-linking hypermedia such as still images, character service, animation, graphic and video files as well as multimedia data. MHEG is user runtime interaction technology and is being applied to various fields including VOD (Video-On-Demand), ITV (Interactive TV), EC (Electronic Commerce), tele-education, tele-conferencing, digital libraries and network games.

□ Light Effect → Off / In Standby / Watching TV / Always

You can turn the LED on/off on the front of TV. Turn it off to save power or if the LED bothers you.

- **Off**: LED is always Off.
- **In Standby**: LED is On when TV is turned off.
- **Watching TV**: LED is On when watching TV.
- **Always**: LED is always On, regardless of TV settings.
- ☑ Set the **Light Effect** to **Off** to reduce the power consumption.
- ☑ The colour of light may vary depending on the model.

❑ Melody → Off / Low / Medium / High

A melody sound can be set to come on when the TV is powered On or Off.

- ☑ The Melody does not play
 - When no sound is output from the TV because the **MUTE** button has been pressed.
 - When no sound is output from the TV because the volume has been reduced to minimum with the volum (-) button.
 - When the TV is turned off by Sleep Timer function.

❑ Energy Saving → Off / Low / Medium / High / Auto

This feature adjusts the brightness of the TV in order to reduce power consumption. When watching TV at night, set the **Energy Saving** mode option to **High** to reduce eye fatigue as well as power consumption.

- ☑ Press the **TOOLS** button to display the **Tools** menu. You can also set the Energy Saving option by selecting **Tools** → **Energy Saving**.

❑ Common Interface

■ CI Menu

This enables the user to select from the CAM-provided menu. Select the CI Menu based on the menu PC Card.

■ Application Info.

This contains information on CAM inserted in the CI slot and displays it. The Application Info inserting is about the CI CARD. You can install the CAM anytime whether the TV is ON or OFF.

1. Purchase the CI CAM module by visiting your nearest dealer or by phone.
2. Insert the CI CARD into the CAM in the direction of the arrow until it fits.
3. Insert the CAM with the CI CARD installed into the common interface slot.
(Insert the CAM in the direction of the arrow, right up to the end so that it is parallel with the slot.)
4. Check if you can see a picture on a scrambled signal channel.

Setting the Time

❑ Clock

Setting the clock is necessary in order to use the various timer features of the TV.

- ☑ The current time will appear every time you press the **INFO** button.
- ☑ If you disconnect the power cord, you have to set the clock again.

■ Clock Mode

You can set up the current time manually or automatically.

- **Auto**: Set the current time automatically using the time from the digital broadcast.
- **Manual**: Set the current time to a manually specified time.
- ☑ Depending on the broadcast station and signal, the auto time may not be set correctly. If this occurs, set the time manually.
- ☑ The Antenna or cable must be connected in order to set the time automatically.

■ Clock Set

You can set the current time manually.

- ☑ This function is only available when **Clock Mode** is set to **Manual**.
- ☑ You can set the day, month, year, hour and minute directly by pressing the number buttons on the remote control.

❑ Sleep Timer

The sleep timer automatically shuts off the TV after a preset time (30, 60, 90, 120, 150 and 180 minutes).

- ☑ Press the **TOOLS** button to display the **Tools** menu. You can also set the sleep timer by selecting **Tools** → **Sleep Timer**.
- ☑ To cancel the **Sleep Timer** function, select **Off**.

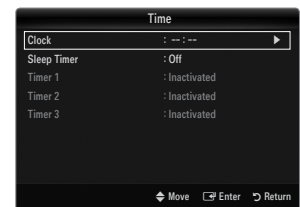
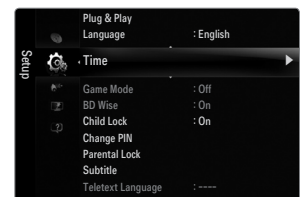

□ **Timer 1 / Timer 2 / Timer 3**

Three different on / off timer settings can be made.
You must set the clock first.

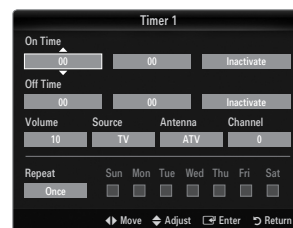

■ **On Time**

Set the hour, minute, and activate / inactivate.
(To activate timer with the setting you've chosen, set to **Activate**.)

■ **Off Time**

Set the hour, minute, and activate / inactivate.
(To activate timer with the setting you've chosen, set to **Activate**.)

■ **Volume**

Set the desired volume level.

■ **Source → TV / USB**

You can select the **TV** or **USB** device content to be played when the TV turns on automatically. Select **TV** or **USB**. (Make sure that an USB device is connected to your TV.)

When there is only one photo file in the **USB**, Slide Show will not be executed.

■ **Antenna (when Source is set to TV)**

Select ATV or DTV.

■ **Channel (when Source is set to TV)**

Select the desired channel.

■ **Contents (when Source is set to USB)**

You can select a folder on the USB Device with music or photo files to be played when the TV turns on automatically.

If the folder name is too long, the folder can not be selected.

If the folder name to be configured by the Contents function is too long, it cannot be selected.

Repeat

Select **Once**, **Everyday**, **Mon-Fri**, **Mon-Sat**, **Sat-Sun** or **Manual**.

When **Manual** is selected, press the ► button to select the desired day of the week. Press the **ENTER**  button over the desired day and the ✓ mark will appear.

You can set the hour, minute and channel by pressing the number buttons on the remote control.

Auto Power Off

When you set the timer on, the television will eventually turn off, if no controls are operated for 3 hours after the TV was turned on by the timer. This function is only available in timer on mode and prevents overheating, which may occur if a TV is on for too long time.

Input Menu

□ Source List

Use to select TV or other external input sources such as DVD / Blu-ray players / Cable Box / Satellite receivers (Set-Top Box) connected to the TV. Use to select the input source of your choice.

- 📄 Press the **SOURCE** button on the remote control to view an external signal source. TV mode can be selected by pressing the TV button, number buttons (0~9), and the P **▲** / **▼** button on the remote control.

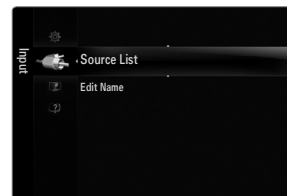

■ TV / Ext. / AV / Component / PC / HDMI1/DVI / HDMI2 / HDMI3 / HDMI4 / USB

- 📄 You can choose only those external devices that are connected to the TV. In the **Source List**, connected inputs will be highlighted and sorted to the top. Inputs that are not connected will be sorted to the bottom.
- 📄 Using the Colour buttons on the remote with the Source list
 - Red (**Refresh**): Refreshes the connected external devices. Press this if your Source is on and connected, but does not appear in the list.
 - **TOOLS (Tools)**: Displays the **Edit Name** and **Information** menus.

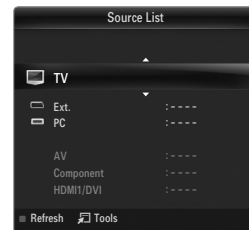

□ Edit Name

■ VCR / DVD / Cable STB / Satellite STB / PVR STB / AV Receiver / Game / Camcorder / PC / DVI / DVI PC / TV / IPTV / Blu-ray / HD DVD / DMA

Name the device connected to the input jacks to make your input source selection easier.

- 📄 When a PC with a resolution of 1920 x 1080@60Hz is connected to the **HDMI IN 1(DVI)** port, you should set the **HDMI1/DVI** mode to **DVI PC** in the **Edit Name** of the **Input** mode.

Support Menu

□ Self Diagnosis

■ Picture Test

If you think you have a picture problem, perform the picture test. Check the colour pattern on the screen to see if the problem still exists.

- **Yes**: If the test pattern does not appear or there is noise in the test pattern, select **Yes**. There may be a problem with the TV. Therefore, contact Samsung's call centre for assistance.
- **No**: If the test pattern is properly displayed, select **No**. There may be a problem with your external equipment. Please check your connections. If the problem still persists, refer to the external device's user manual.

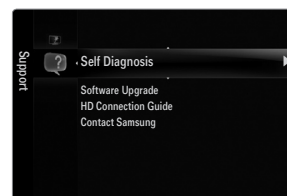

■ Sound Test

If you think you have a sound problem, please perform the sound test. You can check the sound by playing a built-in melody sound through the TV.

- 📄 If you hear no sound from the TV's speakers, before performing the sound test, make sure **Speaker Select** is set to **TV speaker** in the Sound menu.
- 📄 The melody will be heard during the test even if **Speaker Select** is set to **External Speaker** or the sound is muted by pressing the **MUTE** button.
- **Yes**: If during the sound test you can hear sound only from one speaker or not at all, select **Yes**. There may be a problem with the TV. Therefore, contact Samsung's call centre for assistance.
- **No**: If you can hear sound from the speakers, select **No**. There may be a problem with your external equipment. Please check your connections. If the problem still persists, refer to the external device's user manual.

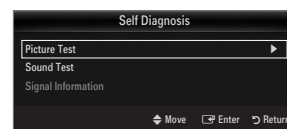

■ Signal Information (digital channels only)

Unlike analogue channels, which can vary in reception quality from 'snowy' to clear, digital (HDTV) channels have either perfect reception quality or you will not receive them at all. So, unlike analogue channels, you cannot fine tune a digital channel. You can, however, adjust your antenna to improve the reception of available digital channels.

- ☑ If the signal strength meter indicates that the signal is weak, physically adjust your antenna to increase the signal strength. Continue to adjust the antenna until you find the best position with the strongest signal.

□ Software Upgrade

Samsung may offer upgrades for the TV's firmware in the future. These upgrades can be performed via the TV when it is connected to the Internet, or by downloading the new firmware from samsung.com to a USB memory device.

- ☑ **Current Version** is the software already installed in the TV.
- ☑ **Alternative Software (Backup)** shows the previous version that will be replaced.
- ☑ Software is represented as 'Year/Month/Day_Version'. The more recent the date, the newer the software version. Installing the latest version is recommended.

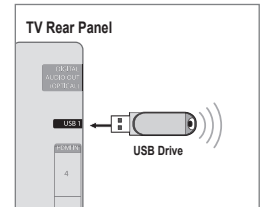

■ By USB

Insert a USB drive containing the firmware upgrade downloaded from samsung.com into the TV. Please be careful to not disconnect the power or remove the USB drive while upgrades are being applied. The TV will turn off and turn on automatically after completing the firmware upgrade. Please check the firmware version after the upgrades are complete (the new version will have a higher number than the older version).

When software is upgraded, video and audio settings you have made will return to their default (factory) settings. We recommend you write down your settings so that you can easily reset them after the upgrade.



■ By Channel

Upgrades the software using the broadcasting signal.

- ☑ If the function is selected during the software transmission period, this function searches for available software and downloads the software.
- ☑ The time required to download the software is determined by the signal status.

■ Standby Mode Upgrade

To continue software upgrade with master power on, Select On by pressing the ▲ or ▼ button. 45 minutes after entering standby mode, a manual upgrade is automatically conducted. Since the power of the unit is turned on internally, the screen may be on slightly for the LED product. This phenomenon may continue for more than 1 hour until the software upgrade is completed.

■ Alternative Software (Backup)

If there is an issue with the new firmware and it is affecting operation, you can change the software to the previous version.

- ☑ If software was changed, existing software is displayed.
- ☑ You can change current software to alternative software by '**Alternative Software**'.

□ HD Connection Guide

This menu presents the connection method that provides the optimal quality for the HD TV. Refer to this information when connecting external devices to the TV.

□ Contact Samsung









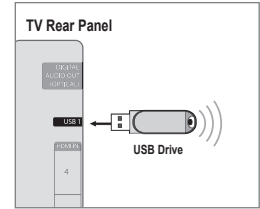







View this information when your TV does not work properly or when you want to upgrade the software. You can view the information regarding the call centre, product and software file download method.

MEDIA PLAY (USB)

Connecting a USB Device







1. Press the **POWER** button to turn the TV on.
2. Connect a USB device containing photo and/or music files to the **USB1** jack on the side of the TV.
3. When the **Application** selection screen is displayed, press the **ENTER**  button to select **Media Play (USB)**.



-  MTP (Media Transfer Protocol) is not supported.
-  The file system supports FAT16, FAT32 and NTFS.
-  Certain types of USB Digital camera and audio devices may not be compatible with this TV.
-  **Media Play** only supports USB Mass Storage Class devices (MSC). MSC is a Mass Storage Class Bulk-Only Transport device. Examples of MSC are Thumb drives, Flash Card Readers and USB HDD (USB HUB are not supported.).
-  Please connect directly to the USB port of your TV. If you are using a separate cable connection, there may be a USB compatibility problem.
-  Before connecting your device to the TV, please back up your files to prevent them from damage or loss of data. SAMSUNG is not responsible for any data file damage or data loss.
-  Do not disconnect the USB device while it is loading.
-  MSC supports MP3 and JPEG files, while a PTP device supports JPEG files only.
-  The higher the resolution of the image, the longer it takes to display on the screen.
-  The maximum supported JPEG resolution is 15360X8640 pixels.
-  For unsupported or corrupted files, the 'Not Supported File Format' message is displayed.
-  If sort key is set to Basic View, up to 1000 files can be displayed in each folder. The other sort key can display up to 10000 files.
-  MP3 files with DRM that have been downloaded from a non-free site cannot be played. Digital Rights Management (DRM) is a technology that supports the creation of content, the distribution and management of the content in an integrated and comprehensive way, including the protection of the rights and interests of the content providers, the prevention of the illegal copying of contents, as well as managing billings and settlements.
-  When moving to a photo, loading may take a few seconds. At this point, the loading icon will appear at the screen.
-  If more than one MSC device is connected, some of them may not be recognized. If a device requires high power (more than 500mA or 5V), the USB device may not be supported.
-  If an over-power warning message is displayed while you are connecting or using a USB device, the device may not be recognized or may malfunction.













Using the Remote Control Button in Media Play Menu

Button	Operations
	Move the cursor and select an item.
ENTER 	Select the currently selected item. While playing a slide show or music file: - Pressing the ENTER  button during play pauses the play. - Pressing the ENTER  button during pause resumes the play.
	Play or pause the Slide Show or music.
RETURN	Return to the previous menu.
TOOLS	Run various functions from the Photo and Music menus.
	Stop the current slide show or Music file.
	Jump to previous group/Jump to next group.
INFO	Show file information.
MEDIA.P	Exit Media Play mode.
^ P ^ , EXIT, TV	Stop Media Play mode and Returns to TV mode.

Media Play Function

This function enables you to view and listen to photo and/or music files saved on a USB Mass Storage Class (MSC) device.

Entering the Media Play (USB) Menu

1. Press the **MENU** button. Press the **▲** or **▼** button to select **Application**, then press the **ENTER**  button.
2. Press the **▲** or **▼** button to select **Media Play (USB)**, then press the **ENTER**  button.
 -  The **Media Play (USB)** menu is displayed.
 -  Press the **MEDIA.P** button on the remote control to display the **Media Play** menu.
 -  Press the **SOURCE** button on the remote control to view the source list. Then Press the **▲** or **▼** button to select **USB**.
3. Press the Red button, then press the **▲** or **▼** button to select the USB Memory. Press the **ENTER**  button.
 -  This function differs depending on the USB Memory Device.
 -  The selected USB device name appears at the bottom left of the screen.
4. Press the **◀** or **▶** button to select an icon (**Photo**, **Music**, **Setup**), then press the **ENTER**  button.
 -  To exit **Media Play** mode, press the **MEDIA.P** button on the remote control.



Removing a USB Memory Device Safely

You can remove the device safely from the TV.

1. Press the **TOOLS** button in the Media Play file list screen, or while a Slide Show or music is being played.
2. Press the **▲** or **▼** button to select **Remove Safely**, then press the **ENTER**  button.
3. Remove the USB device from the TV.

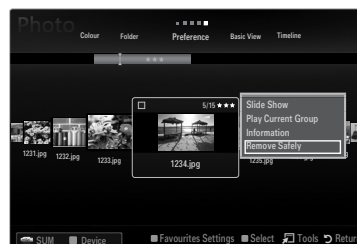

Screen Display

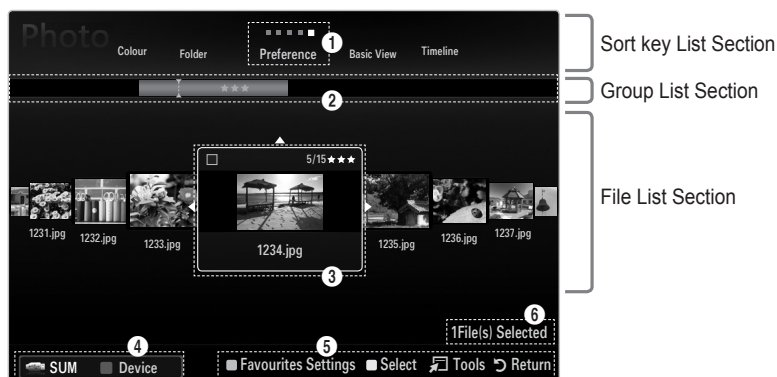

Move to either 'Sort key List Section', 'Group List Section' or 'File List Section' using the Up and Down buttons. After selecting a section, press the **◀** or **▶** buttons to select an item.

- ❶ Current Sort key: This field shows the current standard for sorting files. Press the ◀ or ▶ button to change the standard for sorting files.
- ❷ View Groups: Shows the detailed groups of the files sorted according the selected Sort key. The sort group where the currently selected file is contained is highlighted.
- ❸ Currently selected file: The selected file is the file you can now control. Photo file are displayed as thumbnail images.
- ❹ Current Device: Shows the currently selected device name. Press the Red button to select a device.
 - Red (**Device**) button: Selects a connected device.
- ❺ Item Selection Information: Shows the number of files that are selected by pressing the Yellow button.
- ❻ Help Items
 - Green (**Favourites Settings**) button: Changes the Favourites Settings for the selected file. Press this button repeatedly until the desired value appears.
 - Yellow (**Select**) button: Selects file from the file list. Selected files are marked with a symbol ✓. Press the Yellow button again to cancel a file selection.
 - **TOOLS (Tools)** button: Displays the option menus. (The option menu changes according to the current status.)

Sorting the Photo List

You can sort photos in the Photo List by a particular standard.

1. Press the **MEDIA.P** button.
2. Press the ◀ or ▶ button to select **Photo**, then press the **ENTER** [↵] button.
3. Press the ▲ button to move to the Sort key Section.
4. Press the ◀ or ▶ button to select a sorting standard. (**Basic View, Timeline, Colour, Folder, Preference**)
 - ☑ The photos are sorted according to the newly selected sorting standard.
5. Press the ▼ button to move to the File List Section. Press the ▶ [▶] (Play)/ **ENTER** [↵] button to start the Slide Show in the order you selected.
 - ☑ To move to the previous/next group, press the ◀◀ (REW) or ▶▶ (FF) button.
 - ☑ Photo information is automatically set. The colour information extracted from a photo file may be different from your expectations. You can change the colour and preference.
 - ☑ PTP does not support folder sort mode.



❑ Basic View

Shows the folders on the USB memory device. If you select a folder and press the **ENTER** [↵] button, only the photo files contained in the selected folder are displayed.

- ☑ When sorted according to the **Basic View**, you cannot set Favourites files.

❑ Timeline

Sorts photos by date. It sorts by year and month from the earliest photo.

❑ Colour → Red / Yellow / Green / Blue / Magenta / Black / Gray / Unclassified

Sorts photos by colour. You can change the photo colour information.

- ☑ You should set the **Use Colour View** to on in the **Setup** menu before sorting photos by colour.

❑ Folder



Sorts photos by folder. If there are many folders in USB, the photos files are shown in order in each folder. The photo file in the Root folder is shown first and the others are shown in alphabetical order by name.

❑ Preference → ★★ ★ / ★★ ★★ / ★★ ★★ / ★★ ★★

Sorts photos by preference (Favourites). You can change the photo preferences.

- ☑ Changing the Favourites Settings
Select the desired photo in the Photo list, then press the Green button repeatedly until the desired setting appears.
- ☑ Up to 3 stars can be selected.
- ☑ The stars are for grouping purposes only. For example, the 3 star setting does not have any priority over the one star setting.

Photo List Option Menu

1. Press the **MEDIA.P** button.
2. Press the ◀ or ▶ button to select **Photo**, then press the **ENTER**  button.
3. Press the ▼ button to move to the File List Section.
4. Press the ◀ or ▶ button to select the desired photo file.
 -  **Selecting Multiple Photos**
 - Press the ◀ or ▶ button to select the desired photo file. Then press the Yellow button.
 - Repeat the above operation to select multiple photo files.
 - The mark ✓ appears to the selected photo file.
5. Press the **TOOLS** button.
 -  The option menu changes according to the current status.

Slide Show



Using this menu, you can play a SlideShow using the photo files on the USB memory device.

Play Current Group

Using this menu, you can play a SlideShow using only the photo files in the currently selected sorting group.

Change Group (When the Sort key is the Colour)

You can change a selected photo file's (or group of files) colour information in order to move it from one colour group to another.

-  This does not change the actual colour of the photo.
-  The group information of the current file is updated and the photos are moved to the new colour group.
-  To change the information of multiple files, select the files you want by pressing the Yellow button.



Deselect All (When at least one file is selected)

You can deselect all files.

-  The ✓ mark indicating the corresponding file is selected is hidden.

Information

The photo file information including the name, the size, the resolution, the date modified and the path is displayed.

-  You can view the information of photo files during a SlideShow using the same procedures.
-  Press the **INFO** button to viewing the information.

Remove Safely

You can remove the device safely from the TV.

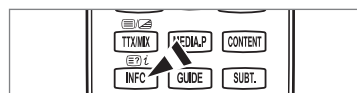
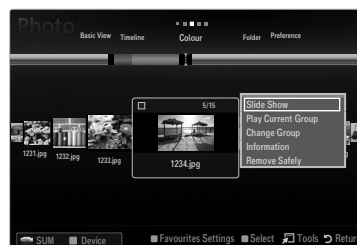

Viewing a Photo or Slide Show

Viewing a Slide Show

1. Press the ▼ button to select the File List Section.
2. Press the **TOOLS** button.
3. Press the ▲ or ▼ button to select **Slide Show**, then press the **ENTER** button.
 - ☑ All files in the photo list will be used for the Slide Show.

☑ During the slide show, files are displayed in order from the currently shown file.

☑ The Slide Show progresses in the order sorted in the Photo list.

☑ Music files can be automatically played during the Slide Show if the **Background Music** is set to **On**.

☑ While a photo list is displayed, press the ▶(Play)/ENTER button on the remote control to start slide show.

☑ SlideShow Control Buttons

Button	Operations
ENTER button	Play/Pause the Slide Show.
▶ button	Play the Slide Show.
⏸ button	Pause the Slide Show.
■ button	Exit Slide Show and return to the photo list.
⏮/⏭ buttons	Change the SlideShow playing speed.
TOOLS	Run various functions from the Photo menus.

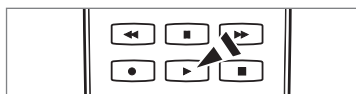
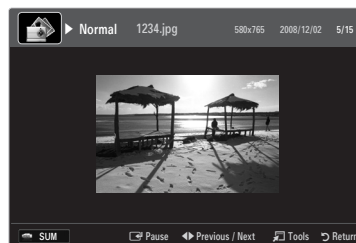
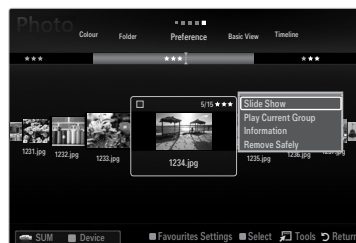

Playing current group

1. Press the ▲ button to move to the Sort key Section.
2. Press the ◀ or ▶ button to select a sorting standard.
3. Press the ▼ button to move to the Group List Section.
4. Select a group using the ◀ and ▶ buttons.
5. Press the ▶ (Play) button. A slideshow begins with the files of the selected group.

● Alternatively

1. Select a Sort key and then in the File List Section, select the photos contained in the desired group.
 - ☑ To move to the previous/next group, press the ⏮ (REW) or ⏭ (FF) button.
2. Press the **TOOLS** button.
3. Press the ▲ or ▼ button to select **Play Current Group**, then press the **ENTER** button.
 - ☑ Only the photos in the sorting group including the selected files will be used for the Slide Show.

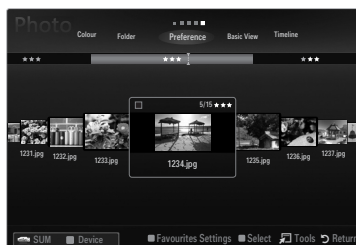

To perform a Slide Show with only the selected files

1. Press the ▼ button to select the File List Section.
2. Press the ◀ or ▶ button to select the desired photo in the Photo list.
3. Press the Yellow button.
4. Repeat the above operation to select multiple photos.
 - ☑ The ✓ mark appears to the left of the selected photo.
 - ☑ If you select one file, the Slide Show will not be performed.
 - ☑ To deselect all selected files, press the **TOOLS** button and select **Deselect All**.
5. Press the ▶ (Play)/ENTER button.
 - ☑ The selected files will be used for the Slide Show.

● **Alternatively**

1. In the Photo List, press the Yellow buttons to select the desired photos.
2. Press the **TOOLS** button.
3. Press the ▲ or ▼ button to select **Slide Show**, then press the ENTER button.
 - ☑ The selected files will be used for the Slide Show.

Slide Show Option Menu

1. During a slide show (or when viewing a photo), press the **TOOLS** button to set the option.
2. Press the ▲ or ▼ button to select the desired option, then press the ENTER button.

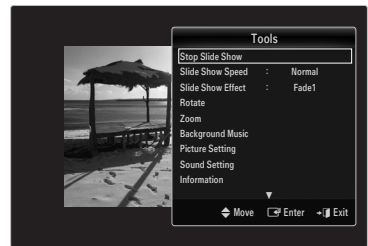

□ **Stop Slide Show / Start Slide Show**

You can start or stop a SlideShow.

□ **Slide Show Speed → Slow / Normal / Fast**

You can select the slide show speed.

- ☑ This function is available only during a slide show.
- ☑ You can also change the speed of the Slide Show by pressing the ◀ (REW) or ▶ (FF) button during the Slide Show.

□ **Slide Show Effect**

You can select the screen transition effect used in the slideshow.

■ **None / Fade1 / Fade2 / Blind / Spiral / Checker / Linear / Stairs / Wipe / Random**

- ☑ This function is available only during a slide show.

□ **Rotate**

You can rotate photos saved on a USB memory device.

- ☑ Whenever you press the ◀ button, it rotates by 270°, 180°, 90°, and 0°.
- ☑ Whenever you press the ▶ button, it rotates by 90°, 180°, 270°, and 0°.
- ☑ The rotated file is not saved.

□ **Zoom**

You can magnify photos saved on a USB memory device. (x1 → x2 → x4)

- ☑ To move the enlarged photo image, press the ENTER button, then press the ▲/▼/◀/▶ buttons. Note that when the enlarged picture is smaller than the original screen size, the location change function doesn't work.
- ☑ The enlarged file is not saved.

❑ **Background Music**

You can select background music when watching a Slide Show.

- 📌 To use this feature, there must be music and photo files stored on the USB device.
- 📌 Loading music files is needed to change BGM mode. Play music files in music category to load.

■ **Background Music → Off / On**

- **Off:** Background music is not played.
- **On:** When the background music is available, if you select **On**, the music is played back.

■ **BGM Mode → Mood / Selected File / Shuffle**

You can select a mode to use for the background music.

■ **BGM Mood → Energetic / Rhythmical / Sad / Exciting / Calm / Unclassified**

Music with the mood you selected is set as the background music.

- 📌 If you set **BGM Mode** to **Mood**, you can select a mood.

■ **Select Music File (0 File(s) Selected)**

Only the selected music file is set as the background music.

- 📌 If you set **BGM Mode** to **Selected File**, you can select a music file.

❑ **Picture Setting / Sound Setting**

You can select the picture and sound settings.

❑ **Information**







The photo file information is displayed.

❑ **Remove Safely**

You can remove the device safely from the TV.

Sorting the Music List

You can sort music files in the Music List by a particular standard.

1. Press the **MEDIA.P** button.
2. Press the ◀ or ▶ button to select **Music**, then press the **ENTER**  button.
3. Press the ▲ button to move to the Sort key Section.
4. Press the ◀ or ▶ button to select a sorting standard. (**Basic View, Title, Artist, Mood, Genre, Folder, Preference**)
 -  The Music files are sorted according to the newly selected sorting standard.
5. Press the ▼ button to move to the File List Section. Press the **ENTER**  button to start playing music in the order selected by the user.
 -  To move to the previous/next group, press the ◀◀ (REW) or ▶▶ (FF) button.
 -  Music information is automatically set. The mood information extracted from a music file may differ from the expectations of the user. You can change the mood and preference.
 -  If there is no title information for a music file, the filename is displayed.
 -  If no information is available for the Artist, Album, Year, or Genre the corresponding item is displayed as blank.

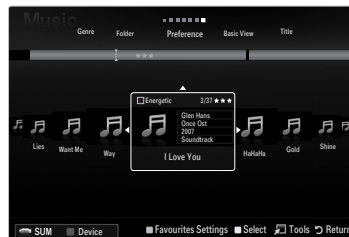

Basic View

Shows the folders of the USB memory device. If you select a folder and press the **ENTER**  button, only the music files contained in the selected folder are displayed.

 When sorted according to the **Basic View**, you cannot set Favourites files.

Title

Sorts the music titles in symbol/number/alphabet/special order, and shows the music file.

Artist

Sorts the music file by artist in symbol/number/alphabet/special order.

Mood → **Energetic / Rhythmical / Sad / Exciting / Calm / Unclassified**

Sorts music files by the mood. You can change the music mood information.

Genre

Sorts music files by the genre.

Folder

Sorts music files by the folder. If there are many folders in USB, the files are shown in order in each folder. The music file in the Root folder is shown first and the others are shown in alphabetical order by name.

Preference → ★★★★★ / ★★★★★ / ★★★★★ / ★★★★★

Sorts music files by preference (Favourites). You can change the music files preferences.



 Changing the Favourites Settings

Select the desired music file in the Music list, then press the Green button repeatedly until the desired setting appears.

 Up to 3 stars can be selected.

 The stars are for grouping purposes only. For example, the 3 star setting does not have any priority over the one star setting.

Music List Option Menu

1. Press the **MEDIA.P** button.
2. Press the ◀ or ▶ button to select **Music**, then press the **ENTER**  button.
3. Press the ▲ button to move to the File List Section.
4. Press the ◀ or ▶ button to select the desired Music file.
 -  **Selecting Multiple Music Files**
 - Press the ◀ or ▶ button to select the desired music file. Then press the Yellow button.
 - Repeat the above operation to select multiple music files.
 - The mark ✓ appears to the selected music file.
5. Press the **TOOLS** button.

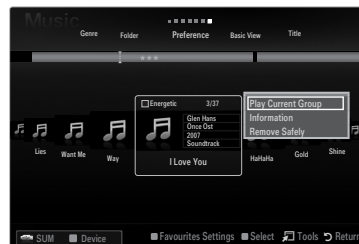

Play Current Group

Using this menu, you can only play music files in the currently selected sorting group.

Change Group (When the Sort key is Mood)

You can change the mood information of music files.

The group information of the current file is updated and the file is moved to the new group.

-  To change the information of multiple files, select files by pressing the Yellow button.



Deselect All (When at least one file is selected)

You can deselect all files.

-  The ✓ mark indicating the corresponding file is selected is hidden.

Information

The music file information including the name, the size, the date modified and the path is displayed.



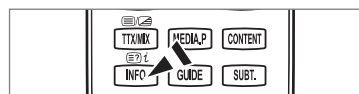



-  You can view the music file information during **Play Current Group** using the same procedures.
-  Press the **INFO** button to viewing the information.



Remove Safely

You can remove the device safely from the TV.

Playing a music file

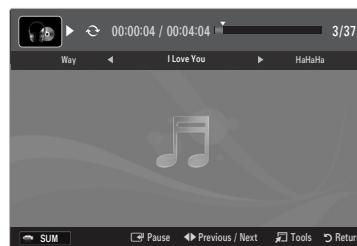

1. Press the **▼** button to select the File List Section.
2. Press the **◀** or **▶** button to select a music file to be played.
3. Press the **▶** (Play)/**ENTER**  button.
 -  This menu only shows files with the MP3 file extension. Files with other file extensions are not displayed, even if they are saved on the same USB device.
 -  The selected file is displayed at the top with its playing time.
 -  To adjust the music volume, press the volume button on the remote control. To mute the sound, press the **MUTE** button on the remote control.
 -  If the sound is odd when playing MP3 files, adjust the **Equalizer** and **SRS TruSurround HD** in the Sound menu. (An over-modulated MP3 file may cause a sound problem.)
 -  The playing duration of a music file may be displayed as '00:00:00' if its playing time information is not found at the start of the file.
 -  **◀◀** (REW) or **▶▶** (FF) buttons do not function during play.







Music Play Control Buttons

Button	Operations
ENTER 	Play/Pause the music file.
▶	Play the music file
⏸	Pause the music file
■	Exit play mode and return to the music list.
TOOLS	Run various functions from the Music menus.





Music function information icon

	When all music files in the folder (or the selected file) are repeated. Repeat Mode is On.
	When all music files in the folder (or the selected file) are played once. Repeat Mode is Off.

Playing the music group

1. Press the **▲** button to move to the Sort key Section.
 2. Press the **◀** or **▶** button to select a sorting standard.
 3. Press the **▼** or **ENTER**  button to move to the Group List Section.
 4. Press the **▶** (Play) button. The files of the selected group will start playing.
- **Alternatively**
 1. Select a sort key and then in the File List Section, select the files contained in the desired group.
 -  To move to the previous/next group, press the **◀◀** (REW) or **▶▶** (FF) button.
 2. Press the **TOOLS** button.
 3. Press the **▲** or **▼** button to select **Play Current Group**, then press the **ENTER**  button.
 -  The music files in the sorting group including the selected file are played.

Playing the selected music files

1. Press the **▼** button to select the File List Section.
2. Press the **◀** or **▶** button to select the desired music file.
3. Repeat the above operation to select multiple music files.
 -  The **✓** appears to the left of the selected music file.
 -  To deselect all selected files, press the **TOOLS** button and select **Deselect All**.
4. Press the **▶** (Play)/**ENTER**  button.
 -  The selected files will be played.

Music Play option Menu

Music Play Option Menu

- ❑ **Repeat Mode → On / Off**
You can play music files repeatedly.
- ❑ **Picture Setting / Sound Setting**
You can configure the picture and sound settings.
- ❑ **Information**
The music file information is displayed.
- ❑ **Remove Safely**
You can remove the device safely from the TV.



Using the Setup Menu

Setup displays the user settings of the **Media Play** menu.

1. Press the **MEDIA.P** button.
 2. Press the ◀ or ▶ button to select **Setup**, then press the **ENTER** button.
 3. Press the ▲ or ▼ button to select the desired option.
 4. Press the ◀ or ▶ button to select the option, then press the **ENTER** button.
✍ To exit **Media Play** mode, press the **MEDIA.P** button on the remote control.
- **Use Colour View → On / Off**
You can select sorting photos by colour. If this option is set to On, the loading time may be increased to collect colour information from the photos.
 - **Music Repeat Mode → On / Off**
Select to repeatedly play music files.
 - **Screen Saver Run Time → 2 hours / 4 hours / 8 hours**
Select to set the waiting time before the screen saver appears.
 - **Information**
Select to viewing the information of the connected device.
 - **Remove Safely**
You can remove the device safely from the TV.

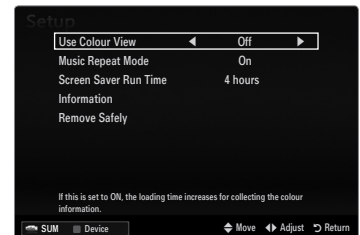

Connecting Anynet+ Devices

What is Anynet+?

Anynet+ is a function that enables you to control all connected Samsung devices that support Anynet+ with your Samsung TV's remote. The Anynet+ system can be used only with Samsung devices that have the Anynet+ feature. To be sure your Samsung device has this feature, check if there is an Anynet+ logo on it.

To connect to a TV

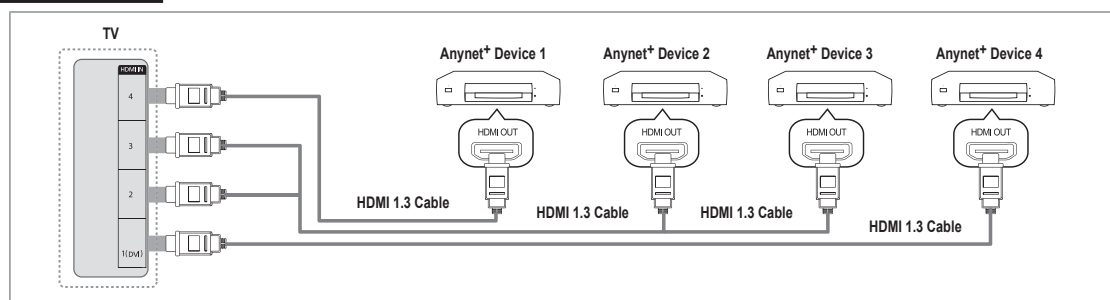

1. Connect the **HDMI IN (1(DVI), 2, 3 or 4)** jack on the TV and the **HDMI OUT** jack of the corresponding Anynet+ device using an HDMI cable.

To connect to Home Theatre

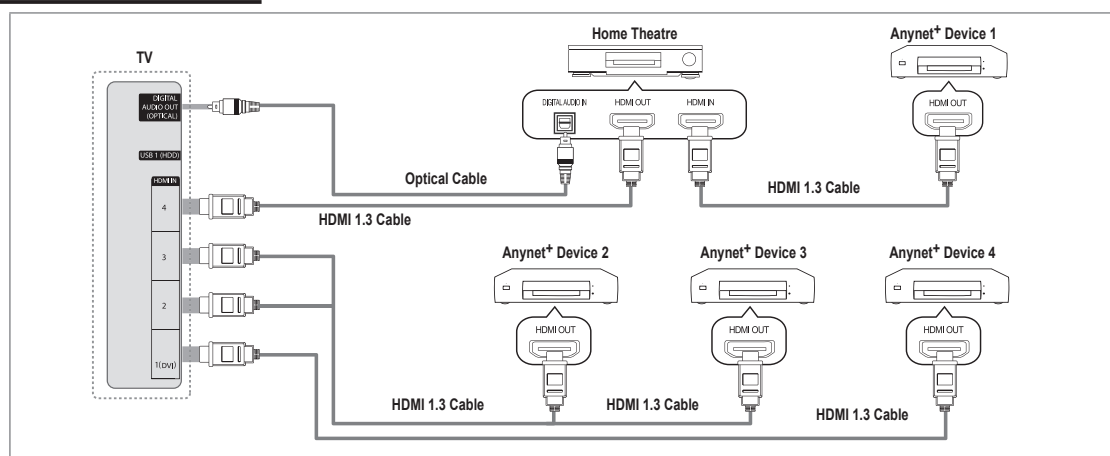

1. Connect the **HDMI IN (1(DVI), 2, 3 or 4)** jack on the TV and the **HDMI OUT** jack of the corresponding Anynet+ device using an **HDMI** cable.
2. Connect the **HDMI IN** jack of the home theatre and the **HDMI OUT** jack of the corresponding Anynet+ device using an **HDMI** cable.
 - Connect the **Optical** cable between the **DIGITAL AUDIO OUT (OPTICAL)** jack on your TV and the **Digital Audio Input** on the Home Theatre.
 - When following the connection above, the **Optical** jack only outputs 2 channel audio. You will only hear sound from the Home Theatre's **Front Left** and **Right** speakers and the **subwoofer**. If you want to hear **5.1** channel audio, connect the **DIGITAL AUDIO OUT (OPTICAL)** jack on the **DVD / Satellite Box** (ie **Anynet Device 1 or 2**) directly to the **Amplifier** or **Home Theatre**, not the **TV**.
 - Connect only one **Home Theatre**.
 - You can connect an **Anynet+ device** using the **HDMI 1.3** cable. Some **HDMI** cables may not support **Anynet+** functions.
 - Anynet+** works when the **AV** device supporting **Anynet+** is in the **Standby** or **On** status.
 - Anynet+** supports up to **12** **AV** devices in total. Note that you can connect up to **3** devices of the same type.
 - Anynet+** supports up to **3** devices simultaneously.

Setting Up Anynet+

- Press the **TOOLS** button to display the **Tools** menu. You can also display Anynet+ menu by selecting **Tools** → **Anynet+ (HDMI-CEC)**.

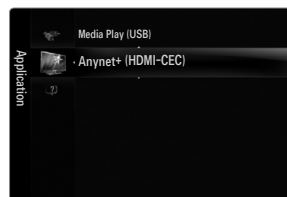

Setup

Anynet+ (HDMI-CEC) → Off / On

To use the Anynet+ Function, **Anynet+ (HDMI-CEC)** must be set to **On**.

- When the **Anynet+ (HDMI-CEC)** function is disabled, all the Anynet+ related operations are deactivated.

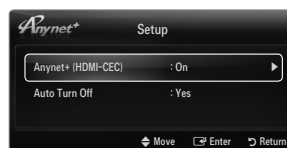

Auto Turn Off → No / Yes

Setting an Anynet+ Device to turn Off automatically when the TV is turned Off.

- The active source on the TV remote must be set to TV to use the Anynet+ function.
- If you set **Auto Turn Off** to **Yes**, connected external devices are also turned off when the TV is turned off. If an external device is still recording, it may or may not turn off.

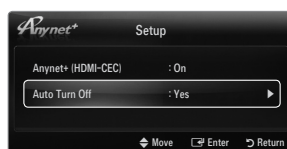

Switching between Anynet+ Devices

- Press the **TOOLS** button. Press the **ENTER** button to select **Anynet+ (HDMI-CEC)**.
 - Press the **▲** or **▼** button to select **Device List**, then press the **ENTER** button.
 - Anynet+ devices connected to the TV are listed.
 - If you cannot find a device you want, press the red button to scan for devices.
 - Press the **▲** or **▼** button to select a particular device and press the **ENTER** button. It is switched to the selected device.
 - Only when you set **Anynet+ (HDMI-CEC)** to **On** in the **Application** menu, the **Device List** menu appears.
- Switching to the selected devices may take up to 2 minutes. You cannot cancel the operation during the switching operation.
 - The time required to scan for devices is determined by the number of connected devices.
 - When the device scan is complete, the number of devices found are not displayed.
 - Although the TV automatically searches the device list when the TV is turned on via the power button, devices connected to the TV may not always be automatically displayed in the device list. Press the red button to search for the connected device.
 - If you have selected external input mode by pressing the **SOURCE** button, you cannot use the Anynet+ function. Make sure to switch to an Anynet+ device by using the **Device List**.



Anynet+ Menu

The Anynet+ menu changes depending on the type and status of the Anynet+ devices connected to the TV.

Anynet+ Menu	Description
View TV	Anynet+ mode changes to TV broadcast mode.
Device List	Shows the Anynet+ device list.
(device_name) Menu	Shows the connected device menus. E.g. If a DVD recorder is connected, the disc menu of the DVD recorder will appear.
(device_name) INFO	Shows the play menu of the connected device. E.g. If a DVD recorder is connected, the play menu of the DVD recorder will appear.
Recording: (*recorder)	Starts recording immediately using the recorder. (This is only available for devices that support the recording function.)
Stop Recording: (*recorder)	Stops recording.
Receiver	Sound is played through the receiver.

- If more than one recording device is connected, they are displayed as (*recorder) and if only one recording device is connected, it will be represented as (*device_name).

TV Remote Control Buttons Available in Anynet+ Mode

Device Type	Operating Status	Available Buttons
Anynet+ Device	After switching to the device, when the menu of the corresponding device is displayed on the screen.	Numeric buttons ▲/▼/◀/▶/ENTER buttons Colour buttons / EXIT button
	After switching to the device, while playing a file	◀◀(Backward search) / ▶▶(Forward search) / ■(Stop) / ▶(Play) / ⏸(Pause)
Device with built-in Tuner	After switching to the device, when you are watching a TV programme	P ▼ / P ▲ button
Audio Device	When Receiver is activated	— + / MUTE button

- ☑ The Anynet+ function only works when the active source on the TV remote control is set to TV.
- ☑ The button works only while in the recordable state.
- ☑ You cannot control Anynet+ devices using the buttons on the TV. You can control Anynet+ devices only using the TV remote control.
- ☑ The TV remote control may not work under certain conditions. If this occurs, reselect the Anynet+ device.
- ☑ The Anynet+ functions do not operate with other manufacturers' products.
- ☑ The ◀◀, ▶▶ operations may differ depending on the device.

Recording

You can make a recording of a TV programme using a Samsung recorder.

- Press the **TOOLS** button. Press the **ENTER** button to select **Anynet+ (HDMI-CEC)**.
- Press the ▲ or ▼ button to select **Recording Immediately** and press the **ENTER** button. Recording begins.
 - ☑ When there is more than one recording device
When multiple recording devices are connected, the recording devices are listed. Press the ▲ or ▼ button to select a recording device and press the **ENTER** button. Recording begins.
 - ☑ When the recording device is not displayed select **Device List** and press the Red button to search devices
- Press the **EXIT** button to exit.
 - ☑ You can record the source streams by selecting **Recording:** (device_name).
 - ☑ Pressing the button will record whatever you are currently watching. If you are watching video from another device, the video from the device is recorded.
 - ☑ Before recording, check whether the antenna jack is properly connected to the recording device. To properly connect an antenna to a recording device, refer to the recording device's users manual.



Listening through a Receiver (Home Theatre)

You can listen to sound through a receiver instead of the TV speaker.

- Press the **TOOLS** button. Press the **ENTER** button to select **Anynet+ (HDMI-CEC)**.
- Press the ▲ or ▼ button to select **Receiver**. Press the ◀ or ▶ button to select **On** or **Off**.
- Press the **EXIT** button to exit.
 - ☑ If your receiver supports audio only, it may not appear in the device list.
 - ☑ The receiver will work when you have properly connected the optical in jack of the receiver to the **DIGITAL AUDIO OUT (OPTICAL)** jack of the TV.
 - ☑ When the receiver (home theatre) is set to On, you can hear sound output from the TV's Optical jack. When the TV is displaying a DTV(air) signal, the TV will send out 5.1 channel sound to the Home Theatre receiver. When the source is a digital component such as a DVD and is connected to the TV via HDMI, only 2 channel sound will be heard from the Home Theatre receiver.
 - ☑ If there is a power interruption to the TV when the **Receiver** is set to **On** (by disconnecting the power cord or a power failure), the **Speaker Select** may be set to **External Speaker** when you turn the TV on again.



Troubleshooting for Anynet+













Problem	Possible Solution
Anynet+ does not work.	<ul style="list-style-type: none"> • Check if the device is an Anynet+ device. The Anynet+ system supports Anynet+ devices only. • Connect only one receiver (home theatre). • Check if the Anynet+ device power cord is properly connected. • Check the Anynet+ device's Video/Audio/HDMI 1.3 cable connections. • Check whether Anynet+ (HDMI-CEC) is set to On in the Anynet+ setup menu. • Check whether the TV remote control is in TV mode. • Check whether it is Anynet+ exclusive remote control. • Anynet+ doesn't work in certain situations. (Searching channels, Operating Media Play, Plug & Play, etc.) • When connecting or removing the HDMI 1.3 cable, please make sure to search devices again or turn your TV off and on again. • Check if the Anynet+ Function of Anynet+ device is set on.
I want to start Anynet+.	<ul style="list-style-type: none"> • Check if the Anynet+ device is properly connected to the TV and check if the Anynet+ (HDMI-CEC) is set to On in the Anynet+ Setup menu. • Press the TV button on the TV remote control to switch to TV. Then press the TOOLS button to show the Anynet+ menu and select a menu you want.
I want to exit Anynet+.	<ul style="list-style-type: none"> • Select View TV in the Anynet+ menu. • Press the SOURCE button on the TV remote control and select a device other than Anynet+ devices. • Press P ∇/\wedge, PRE-CH and FAV.CH to change the TV mode. (Note that the channel button operates only when a tuner-embedded Anynet+ device is not connected.)
The message 'Connecting to Anynet+ device...' appears on the screen.	<ul style="list-style-type: none"> • You cannot use the remote control when you are configuring Anynet+ or switching to a view mode. • Use the remote control when the Anynet+ setting or switching to view mode is complete.
The Anynet+ device does not play.	<ul style="list-style-type: none"> • You cannot use the play function when Plug & Play is in progress.
The connected device is not displayed.	<ul style="list-style-type: none"> • Check whether or not the device supports Anynet+ functions. • Check whether or not the HDMI 1.3 cable is properly connected. • Check whether Anynet+ (HDMI-CEC) is set to On in the Anynet+ setup menu. • Search Anynet+ devices again. • You can connect an Anynet+ device using the HDMI 1.3 cable only. Some HDMI cables may not support Anynet+ functions. • If it is terminated by an abnormal situation such as disconnecting the HDMI cable or power cord or a power failure, please repeat the device scan.
The TV programme cannot be recorded.	<ul style="list-style-type: none"> • Check whether the antenna jack on the recording device is properly connected.
The TV sound is not output through the receiver.	<ul style="list-style-type: none"> • Connect the optical cable between TV and the receiver.

RECOMMENDATIONS

Teletext Feature

Most television stations provide written information services via Teletext. The index page of the Teletext service gives you information on how to use the service. In addition, you can select various options to suit your requirements by using the remote control buttons.

☑ For Teletext information to be displayed correctly, channel reception must be stable. Otherwise, information may be missing or some pages may not be displayed.

- 1  (exit)
Exit from the Teletext display.
- 2  (store)
Used to store the Teletext pages.
- 3  (size)
Press to display the double-size letters in the upper half of the screen. For lower half of the screen, press it again. To display normal screen, press it once again.
- 4 Colour buttons (red/green/yellow/blue)
If the FASTEXT system is used by a broadcasting company, the different topics covered on a Teletext page are colour-coded and can be selected by pressing the coloured buttons. Press one of them corresponding to the required. The page is displayed with other coloured information that can be selected in the same way. To display the previous or next page, press the corresponding coloured button.
- 5  (mode)
Press to select the Teletext mode (LIST/ FLOF). If you press it in the LIST mode, it switches into the List save mode. In the List save mode, you can save Teletext page into list using the  (store) button.
- 6  (Teletext on/mix)
Press to activate Teletext mode after selecting the channel providing the Teletext service. Press it twice to overlap the Teletext with the current broadcasting screen.
- 7  (reveal)
Used to display the hidden text (answers to quiz games, for example). To display normal screen, press it again.
- 8  (sub-page)
Used to display the available sub-page.
- 9  (index)
Used to display the index (contents) page at any time while you are viewing Teletext.
- 10  (hold)
Used to hold the display on a given page if the selected page is linked with several secondary pages which follow on automatically. To resume, press it again.
- 11  (cancel)
Used to display the broadcast when searching for a page.
- 12  (page up)
Used to display the next Teletext page.
- 13  (page down)
Used to display the previous Teletext page.

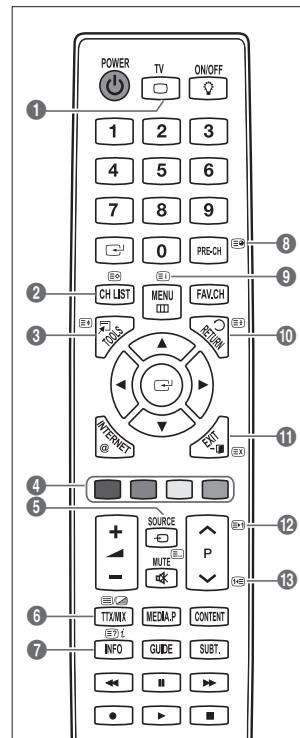

☑ You can change Teletext pages by pressing the numeric buttons on the remote control.

The Teletext pages are organized according to six categories:

Part	Contents
A	Selected page number.
B	Broadcasting channel identity.
C	Current page number or search indications.
D	Date and time.
E	Text.
F	Status information. FASTEXT information.

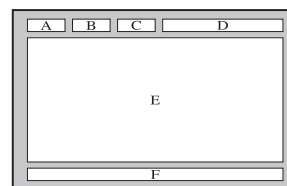

- ☑ Teletext information is often divided between several pages displayed in sequence, which can be accessed by:
 - Entering the page number
 - Selecting a title in a list
 - Selecting a coloured heading (FASTEXT system)
- ☑ Teletext level supported by the TV is version 2.5 which is capable of displaying additional graphics or text.
- ☑ Depending upon the transmission, blank side panels can occur when displaying Teletext.
- ☑ In these cases, additional graphics or text is not transmitted.
- ☑ Older TV's which do not support version 2.5 are not capable of displaying any additional graphics or text, regardless of the Teletext transmission.
- ☑ Press the **TV** button to exit from the Teletext display.

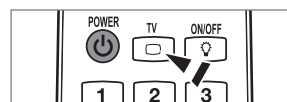

Installing the Stand

- ☑ **Preset:** Place the Guide Stand and Cover Neck onto the stand and fasten it using the screws. Applicable to 32inch models only.

1. Attach your LED TV to the stand.

- ☑ Two or more people should carry the TV.
- ☑ Make sure to distinguish between the front and back of the stand when assembling them.
- ☑ To make sure the TV is installed on the stand at a proper level, do not apply excess downward pressure to the upper left or right sides of the TV.

2. Fasten screws at position ❶ and then fasten screws at position ❷.

- ☑ Stand the product up and fasten the screws. If you fasten the screws with the LED TV placed down, it may lean to one side.

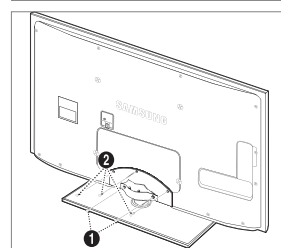
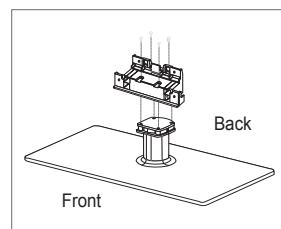

Disconnecting the Stand

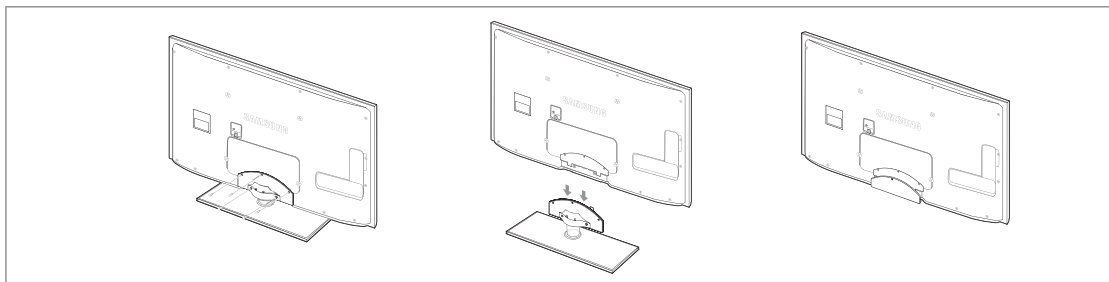

1. Remove four screws from the back of the TV.
2. Separate the stand from the TV.
 - ☑ Two or more people should carry the TV.
3. Cover the bottom hole with the cover.

Installing the Wall Mount Kit

Wall mount items (sold separately) allow you to mount the TV on the wall.

For detailed information on installing the wall mount, see the instructions provided with the Wall Mount items. Contact a technician for assistance when installing the wall mounted bracket.

Samsung Electronics is not responsible for any damage to the product or injury to yourself or others if you elect to install the TV on your own.



Do not install your Wall Mount Kit while your TV is turned on. It may result in personal injury due to electric shock.

- ☑ Remove the stand and cover the bottom hole with a cap and fasten with two screws.

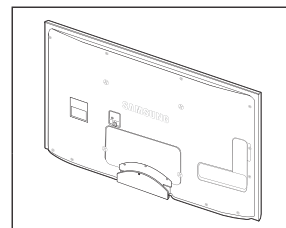

Anti-Theft Kensington Lock

The Kensington Lock is a device used to physically fix the system when using it in a public place. The appearance and locking method may differ from the illustration depending on the manufacturer.

Refer to the manual provided with the Kensington Lock for proper use.

- ☑ The locking device has to be purchased separately.
 - ☑ The location of the Kensington Lock may be different depending on its model.
1. Insert the locking device into the Kensington slot on the LED TV (❶) and turn it in the locking direction (❷).
 2. Connect the Kensington Lock cable (❸).
 3. Fix the Kensington Lock to a desk or a heavy stationary object.

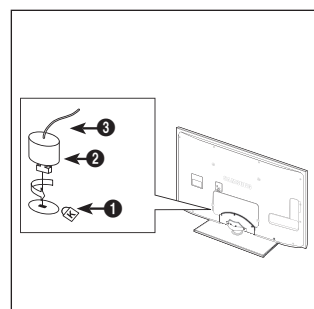

Preparing before installing Wall-Mount

To install a wall-mount from another manufacturer, use the Holder-Ring ❶.

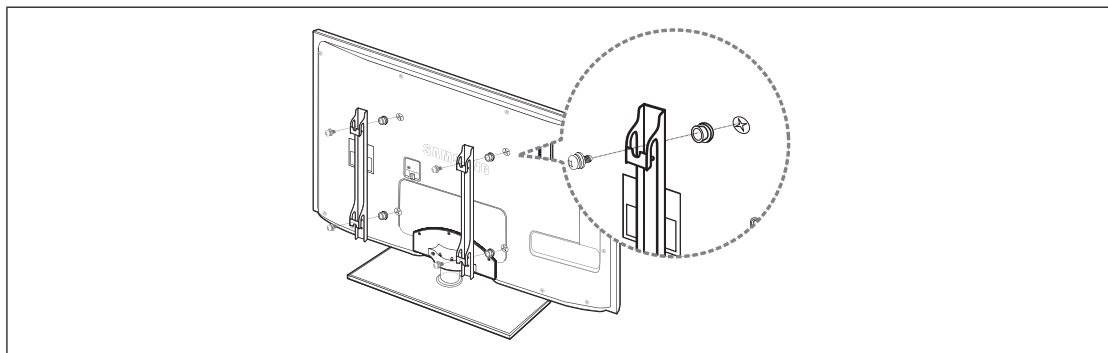

Securing the TV to the Wall



Caution: Pulling, pushing, or climbing on the TV may cause the TV to fall. In particular, ensure your children do not hang over or destabilize the TV; doing so may cause the TV to tip over, causing serious injuries or death. Follow all safety precautions provided on the included Safety Flyer. For added stability, install the anti-fall device for safety purposes, as follows.

■ To avoid the TV from falling:

- Put the screws into the clamps and firmly fasten them onto the wall. Confirm that the screws have been firmly installed onto the wall.
 - ☑ You may need additional material such as an anchor depending on the type of wall.
 - ☑ Since the necessary clamps, screws, and string are not supplied, please purchase these additionally.
- Remove the screws from the centre back of the TV, put the screws into the clamps, and then fasten the screws onto the TV again.
 - ☑ Screws may not be supplied with the product. In this case, please purchase the screws of the following specifications.
 - ☑ Screw Specifications
 - For a 32 ~ 40 Inch LED TV: M6 X L15
 - For a 40 ~ 55 inch LED TV : M8 X L30
- Connect the clamps fixed onto the TV and the clamps fixed onto the wall with a strong string and then tie the string tightly.
 - ☑ Install the TV near to the wall so that it does not fall backwards.
 - ☑ It is safe to connect the string so that the clamps fixed on the wall are equal to or lower than the clamps fixed on the TV.
 - ☑ Untie the string before moving the TV.
- Verify all connections are properly secured. Periodically check connections for any sign of fatigue for failure. If you have any doubt about the security of your connections, contact a professional installer.

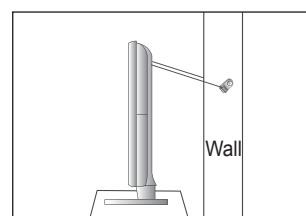
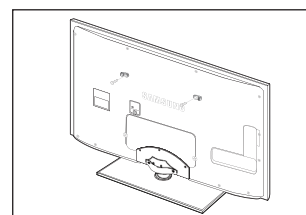
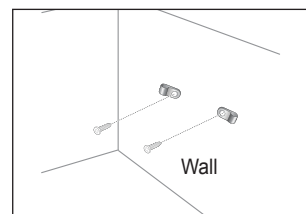

Troubleshooting: Before Contacting Service Personnel

No sound or picture	Check that the mains lead has been connected to a wall socket. Check that you have pressed the button on your set. Check the picture contrast and brightness settings. Check the volume.
Normal picture but no sound	Check the volume. Check whether the MUTE button has been pressed on the remote control. Check the Speaker Select settings.
Screen is black and power indicator light blinks steadily	On your computer check; Power, Signal Cable. The TV is using its power management system. Move the computer's mouse or press any key on the keyboard.
No picture or black and white picture	Adjust the colour settings. Check that the broadcast system selected is correct.
Sound and picture interference	Try to identify the electrical appliance that is affecting the set and move it further away. Plug your set into a different mains socket.
Blurred or snowy picture, distorted sound	Check the direction, location and connections of your aerial. This interference is often due to the use of an indoor aerial.
Remote control malfunctions	Replace the remote control batteries. Clean the upper edge of the remote control (transmission window). Check the battery terminals.
'Check signal cable.' message is displayed	Check that the signal cable is firmly connected to the PC or video sources. Check that the PC or video sources are turned on.
On PC mode, 'Not Supported Mode.' message is displayed	Check the maximum resolution and the frequency of the video adaptor. Compare these values with the data in the Display Modes.
The damaged picture appears in the corner of the screen	If Screen Fit is selected in some external devices, the damaged picture may appear in the corner of the screen. This symptom is caused by external devices, not TV.
The 'Resets all settings to the default values.' message appears.	This appears when you press and hold the EXIT button for a while. The product settings are reset to the factory defaults.
You may see small particles if you look closely at the edge of the bezel surrounding the TV screen.	This is part of the product's design and is not a defect.

- ☑ This TFT LED panel uses a panel consisting of sub pixels (6 220 800) which require sophisticated technology to produce. However, there may be few bright or dark pixels on the screen. These pixels will have no impact on the performance of the product.

Specifications

Model Name	UE40B6000	UE46B6000
Screen Size (Diagonal)	40 inch	46 inch
Power Consumption Standby	<1W	<1W
PC Resolution (Optimum)	1920 x 1080 @ 60 Hz	1920 x 1080 @ 60 Hz
Sound (Output)	10W x 2	10W x 2
Dimensions (WxDxH) Body With stand	983 X 30 X 631 mm 983 X 255 X 688 mm	1115 X 30 X 705 mm 1115 X 275 X 763 mm
Weight With Stand	18 kg	23 kg
Environmental Considerations Operating Temperature Operating Humidity Storage Temperature Storage Humidity	10°C to 40°C (50°F to 104°F) 10% to 80%, non-condensing -20°C to 45°C (-4°F to 113°F) 5% to 95%, non-condensing	
Stand Swivel (Left / Right)	-20° ~ 20°	

- ☑ Design and specifications are subject to change without prior notice.
- ☑ This device is a Class B digital apparatus.
- ☑ For the power supply and Power Consumption, refer to the label attached to the product.

Warning! Important Safety Instructions

Please read the appropriate section that corresponds to the marking on your Samsung product before attempting to install the product.

CAUTION

RISK OF ELECTRIC SHOCK DO NOT OPEN

CAUTION: TO REDUCE THE RISK OF ELECTRIC SHOCK, DO NOT REMOVE COVER (OR BACK). THERE ARE NO USER SERVICEABLE PARTS INSIDE. REFER ALL SERVICING TO QUALIFIED PERSONNEL.



This symbol indicates that high voltage is present inside. It is dangerous to make any kind of contact with any internal part of this product.



This symbol alerts you that important literature concerning operation and maintenance has been included with this product.

- The slots and openings in the cabinet and in the back or bottom are provided for necessary ventilation. To ensure reliable operation of this apparatus, and to protect it from overheating, these slots and openings must never be blocked or covered.
 - Do not cover the slots and openings with a cloth or other materials.
 - Do not block the slots and openings by placing this apparatus on a bed, sofa, rug or other similar surface.
 - Do not place this apparatus in a confined space, such as a bookcase, or built-in cabinet, unless proper ventilation is provided.Give your product 10 cm (4 inch) clearance from the wall.
- Do not place this apparatus near or over a radiator or heat resistor, or where it is exposed to direct sunlight.
- Do not place heat generating items such as candles, ashtrays, incense, flammable gas or explosive materials near the product.
- Do not place a water containing vessel on this apparatus, as this can result in a risk of fire or electric shock.
- Do not expose this apparatus to rain or place it near water (near a bathtub, washbowl, kitchen sink, or laundry tub, in a wet basement, or near a swimming pool etc.). If this apparatus accidentally gets wet, unplug it and contact an authorized dealer immediately. Make sure to pull out the power cord from the outlet before cleaning.
- This apparatus use batteries. In your community there might be regulations that require you to dispose of these batteries properly under environmental considerations. Please contact your local authorities for disposal or recycling information.
- Do not overload wall outlets, extension cords or adaptors beyond their capacity, since this can result in fire or electric shock.
- Power-supply cords should be routed so that they are not likely to be walked on or pinched by items placed upon or against them, paying particular attention to cords at plug end, adaptors and the point where they exit from the appliance.
- To protect this apparatus from a lightning storm, or when it is left unattended and unused for long periods of time, unplug it from the wall outlet and disconnect the antenna or cable system.
This will prevent damage to the set due to lightning and power line surges.
- Before connecting the AC power cord to the DC adaptor outlet, make sure the voltage designation of the DC adaptor corresponds to the local electrical supply.
- Never insert anything metallic into the open parts of this apparatus. Doing so may create a danger of electric shock.
- To avoid electric shock, never touch the inside of this apparatus. Only a qualified technician should open this apparatus.
- Make sure to plug the power cord in until it is firmly inserted. When removing the power cord, make sure to hold the power plug when pulling the plug from the outlet. Do not touch the power cord with wet hands.
- If this apparatus does not operate normally - in particular, if there are any unusual sounds or smells coming from it unplug it immediately and contact an authorized dealer or service center.
- Be sure to pull the power plug out of the outlet if the TV is to remain unused or if you are to leave the house for an extended period of time (especially when children, elderly or disabled people will be left alone in the house).
Accumulated dust can cause an electric shock, an electric leakage or a fire by causing the power cord to generate sparks and heat or the insulation to deteriorate.
- Be sure to contact an authorized service center, when installing your set in a location with heavy dust, high or low temperatures, high humidity, chemical substances and where it operates for 24 hours such as the airport, the train station etc. Failure to do so may cause serious damage to your set.
- Use only a properly grounded plug and receptacle.
An improper ground may cause electric shock or equipment damage. (Class I Equipment only.)
- To disconnect the apparatus from the mains, the plug must be pulled out from the mains socket, therefore the mains plug shall be readily operable.
- Do not allow children to hang onto the product.
- Store the accessories (battery, etc.) in a location safely out of the reach of children.
- Do not install the product in an unstable location such as a shaky shelf, a slanted floor or a location exposed to vibration.
- Do not drop or impart any shock to the product. If the product is damaged, disconnect the power cord and contact a service center.



**WARNING - TO PREVENT THE SPREAD OF FIRE,
KEEP CANDLES OR OTHER OPEN FLAMES
AWAY FROM THIS PRODUCT AT ALL TIMES.**

Wiring the Mains Power Supply Plug (UK Only)

IMPORTANT NOTICE

The mains lead on this equipment is supplied with a moulded plug incorporating a fuse. The value of the fuse is indicated on the pin face of the plug and, if it requires replacing, a fuse approved to BSI1362 of the same rating must be used. Never use the plug with the fuse cover omitted if the cover is detachable. If a replacement fuse cover is required, it must be of the same colour as the pin face of the plug. Replacement covers are available from your dealer.

If the fitted plug is not suitable for the power points in your house or the cable is not long enough to reach a power point, you should obtain a suitably approved extension lead or consult your dealer for assistance. However, if there is no alternative but to cut off the plug, remove the fuse and then safely dispose of the plug.

Do NOT connect the plug to a mains socket as there is a risk of shock hazard from the bared flexible cord.

IMPORTANT

The wires in the mains lead are coloured in accordance with the following code:

BLUE - NEUTRAL BROWN - LIVE

As these colours may not correspond to the coloured markings identifying the terminals in your plug, proceed as follows :

The wire coloured BLUE must be connected to the terminal marked with the letter N or coloured BLUE or BLACK. The wire coloured BROWN must be connected to the terminal marked with the letter L or coloured BROWN or RED.

WARNING:

DO NOT CONNECT EITHER WIRE TO THE EARTH TERMINAL, WHICH IS MARKED WITH THE LETTER E OR BY THE EARTH SYMBOL ⊕, OR COLOURED GREEN OR GREEN AND YELLOW.

Warranty Card



UNITED KINGDOM

This Samsung product is warranted for a period of twelve (12) months from the original date of purchase, against defective materials and workmanship. In the event that warranty service is required, you should return the product to the retailer from whom it was purchased. However, Samsung Authorised Dealers and Authorised Service Centres in other EC Countries will comply with the warranty on the terms issued to purchasers in the country concerned. In case of difficulty, details of our Authorised Service Centres are available from:

Samsung Electronics U.K. Ltd.
Customer Care Centre
PO Box 17243
Edinburgh, EH11 4YB
United Kingdom
Tel: 0845 SAMSUNG (7267864) (UK & Northern Ireland)
Tel: 0818 717 100 (EIRE Only)
Fax: +44 0845 650 8080
Web : www.samsung.com

WARRANTY CONDITIONS

1. The warranty is only valid if, when warranty service is required, the warranty card is fully and properly completed and is presented with the original invoice or sales slip or confirmation, and the serial number on the product has not been defaced.
2. Samsung's obligations are limited to the repair or, at its discretion, replacement of the product or the defective part.
3. Warranty repairs must be carried out by Authorised Samsung Dealers or Authorised Service Centres. No re-imbursment will be made for repairs carried out by non Samsung Dealers and, any such repair work and damage to the products caused by such repair work will not be covered by this warranty.
4. This product is not considered to be defective in materials nor workmanship by reason that it requires adaptation in order to conform to national or local technical or safety standards in force in any Country other than the one for which the product was originally designed and manufactured.

- This product uses parts of the software from the Independent JPEG Group.
- This product uses parts of the software owned by the Freetype Project (www.freetype.org).
- This product uses some software programs which are distributed under the GPL/LGPL license. Accordingly, the following GPL and LGPL software source codes that have been used in this product can be provided after asking to vdswwmanager@samsung.com.
 GPL software: Linux Kernel, Busybox, Binutils
 LGPL software: Glibc, ffmpeg, smpeg, libphoto, libusb, SDL

GNU GENERAL PUBLIC LICENSE

Version 3, 29 June 2007

Copyright (C) 2007 Free Software Foundation, Inc. <<http://fsf.org/>>

Everyone is permitted to copy and distribute verbatim copies of this license document, but changing it is not allowed.

Preamble

The GNU General Public License is a free, copyleft license for software and other kinds of works.

The licenses for most software and other practical works are designed to take away your freedom to share and change the works. By contrast, the GNU General Public License is intended to guarantee your freedom to share and change all versions of a program--to make sure it remains free software for all its users. We, the Free Software Foundation, use the GNU General Public License for most of our software; it applies also to any other work released this way by its authors. You can apply it to your programs, too.

When we speak of free software, we are referring to freedom, not price. Our General Public Licenses are designed to make sure that you have the freedom to distribute copies of free software (and charge for them if you wish), that you receive source code or can get it if you want it, that you can change the software or use pieces of it in new free programs, and that you know you can do these things.

To protect your rights, we need to prevent others from denying you these rights or asking you to surrender the rights. Therefore, you have certain responsibilities if you distribute copies of the software, or if you modify it: responsibilities to respect the freedom of others.

For example, if you distribute copies of such a program, whether gratis or for a fee, you must pass on to the recipients the same freedoms that you received. You must make sure that they, too, receive or can get the source code. And you must show them these terms so they know their rights.

Developers that use the GNU GPL protect your rights with two steps: (1) assert copyright on the software, and (2) offer you this License giving you legal permission to copy, distribute and/or modify it.

For the developers' and authors' protection, the GPL clearly explains that there is no warranty for this free software. For both users' and authors' sake, the GPL requires that modified versions be marked as changed, so that their problems will not be attributed erroneously to authors of previous versions.

Some devices are designed to deny users access to install or run modified versions of the software inside them, although the manufacturer can do so. This is fundamentally incompatible with the aim of protecting users' freedom to change the software. The systematic pattern of such abuse occurs in the area of products for individuals to use, which is precisely where it is most unacceptable. Therefore, we have designed this version of the GPL to prohibit the practice for those products. If such problems arise substantially in other domains, we stand ready to extend this provision to those domains in future versions of the GPL, as needed to protect the freedom of users.

Finally, every program is threatened constantly by software patents. States should not allow patents to restrict development and use of software on general-purpose computers, but in those that do, we wish to avoid the special danger that patents applied to a free program could make it effectively proprietary. To prevent this, the GPL assures that patents cannot be used to render the program non-free.

The precise terms and conditions for copying, distribution and modification follow.

TERMS AND CONDITIONS

0. Definitions.

"This License" refers to version 3 of the GNU General Public License.

"Copyright" also means copyright-like laws that apply to other kinds of works, such as semiconductor masks.

"The Program" refers to any copyrightable work licensed under this License. Each licensee is addressed as "you". "Licensees" and "recipients" may be individuals or organizations.

To "modify" a work means to copy from or adapt all or part of the work in a fashion requiring copyright permission, other than the making of an exact copy. The resulting work is called a "modified version" of the earlier work or a work "based on" the earlier work.

A "covered work" means either the unmodified Program or a work based on the Program.

To "propagate" a work means to do anything with it that, without permission, would make you directly or secondarily liable for infringement under applicable copyright law, except executing it on a computer or modifying a private copy. Propagation includes copying, distribution (with or without modification), making available to the public, and in some countries other activities as well.

To "convey" a work means any kind of propagation that enables other parties to make or receive copies. Mere interaction with a user through a computer network, with no transfer of a copy, is not conveying.

An interactive user interface displays "Appropriate Legal Notices" to the extent that it includes a convenient and prominently visible feature that (1) displays an appropriate copyright notice, and (2) tells the user that there is no warranty for the work (except to the extent that warranties are provided), that licensees may convey the work under this License, and how to view a copy of this License. If the interface presents a list of user commands or options, such as a menu, a prominent item in the list meets this criterion.

1. Source Code.

The "source code" for a work means the preferred form of the work for making modifications to it. "Object code" means any non-source form of a work.

A "Standard Interface" means an interface that either is an official standard defined by a recognized standards body, or, in the case of interfaces specified for a particular programming language, one that is widely used among developers working in that language.

The "System Libraries" of an executable work include anything, other than the work as a whole, that (a) is included in the normal form of packaging a Major Component, but which is not part of that Major Component, and (b) serves only to enable use of the work with that Major Component, or to implement a Standard Interface for which an implementation is available to the public in source code form. A "Major Component", in this context, means a major essential component (kernel, window system, and so on) of the specific operating system (if any) on which the executable work runs, or a compiler used to produce the work, or an object code interpreter used to run it.

The "Corresponding Source" for a work in object code form means all the source code needed to generate, install, and (for an executable work) run the object code and to modify the work, including scripts to control those activities. However, it does not include the work's System Libraries, or general-purpose tools or generally available free programs which are used unmodified in performing those activities but which are not part of the work. For example, Corresponding Source includes interface definition files associated with source files for the work, and the source code for shared libraries and dynamically linked subprograms that the work is specifically designed to require, such as by intimate data communication or control flow between those subprograms and other parts of the work.

The Corresponding Source need not include anything that users can regenerate automatically from other parts of the Corresponding Source.

The Corresponding Source for a work in source code form is that same work.

2. Basic Permissions.

All rights granted under this License are granted for the term of copyright on the Program, and are irrevocable provided the stated conditions are met. This License explicitly affirms your unlimited permission to run the unmodified Program. The output from running a covered work is covered by this License only if the output, given its content, constitutes a covered work.

This License acknowledges your rights of fair use or other equivalent, as provided by copyright law. You may make, run and propagate covered works that you do not convey, without conditions so long as your license otherwise remains in force. You may convey covered works to others for the sole purpose of having them make modifications exclusively for you, or provide you with facilities for running those works, provided that you comply with the terms of this License in conveying all material for which you do not control copyright. Those thus making or running the covered works for you must do so exclusively on your behalf, under your direction and control, on terms that prohibit them from making any copies of your copyrighted material outside their relationship with you.

Conveying under any other circumstances is permitted solely under the conditions stated below. Sublicensing is not allowed; section 10 makes it unnecessary.

3. Protecting Users' Legal Rights From Anti-Circumvention Law.

No covered work shall be deemed part of an effective technological measure under any applicable law fulfilling obligations under article 11 of the WIPO copyright treaty adopted on 20 December 1996, or similar laws prohibiting or restricting circumvention of such measures.

When you convey a covered work, you waive any legal power to forbid circumvention of technological measures to the extent such circumvention is effected by exercising rights under this License with respect to the covered work, and you disclaim any intention to limit operation or modification of the work as a means of enforcing, against the work's users, your or third parties' legal rights to forbid circumvention of technological measures.

4. Conveying Verbatim Copies.

You may convey verbatim copies of the Program's source code as you receive it, in any medium, provided that you conspicuously and appropriately publish on each copy an appropriate copyright notice; keep intact all notices stating that this License and any non-permissive terms added in accord with section 7 apply to the code; keep intact all notices of the absence of any warranty; and give all recipients a copy of this License along with the Program.

You may charge any price or no price for each copy that you convey, and you may offer support or warranty protection for a fee.

5. Conveying Modified Source Versions.

You may convey a work based on the Program, or the modifications to produce it from the Program, in the form of source code under the terms of section 4, provided that you also meet all of these conditions:

- a) The work must carry prominent notices stating that you modified it, and giving a relevant date.
- b) The work must carry prominent notices stating that it is released under this License and any conditions added under section 7. This requirement modifies the requirement in section 4 to “keep intact all notices”.
- c) You must license the entire work, as a whole, under this License to anyone who comes into possession of a copy. This License will therefore apply, along with any applicable section 7 additional terms, to the whole of the work, and all its parts, regardless of how they are packaged. This License gives no permission to license the work in any other way, but it does not invalidate such permission if you have separately received it.
- d) If the work has interactive user interfaces, each must display Appropriate Legal Notices; however, if the Program has interactive interfaces that do not display Appropriate Legal Notices, your work need not make them do so.

A compilation of a covered work with other separate and independent works, which are not by their nature extensions of the covered work, and which are not combined with it such as to form a larger program, in or on a volume of a storage or distribution medium, is called an “aggregate” if the compilation and its resulting copyright are not used to limit the access or legal rights of the compilation’s users beyond what the individual works permit. Inclusion of a covered work in an aggregate does not cause this License to apply to the other parts of the aggregate.

6. Conveying Non-Source Forms.

You may convey a covered work in object code form under the terms of sections 4 and 5, provided that you also convey the machine-readable Corresponding Source under the terms of this License, in one of these ways:

- a) Convey the object code in, or embodied in, a physical product (including a physical distribution medium), accompanied by the Corresponding Source fixed on a durable physical medium customarily used for software interchange.
- b) Convey the object code in, or embodied in, a physical product (including a physical distribution medium), accompanied by a written offer, valid for at least three years and valid for as long as you offer spare parts or customer support for that product model, to give anyone who possesses the object code either (1) a copy of the Corresponding Source for all the software in the product that is covered by this License, on a durable physical medium customarily used for software interchange, for a price no more than your reasonable cost of physically performing this conveying of source, or (2) access to copy the Corresponding Source from a network server at no charge.
- c) Convey individual copies of the object code with a copy of the written offer to provide the Corresponding Source. This alternative is allowed only occasionally and noncommercially, and only if you received the object code with such an offer, in accord with subsection 6b.
- d) Convey the object code by offering access from a designated place (gratis or for a charge), and offer equivalent access to the Corresponding Source in the same way through the same place at no further charge. You need not require recipients to copy the Corresponding Source along with the object code. If the place to copy the object code is a network server, the Corresponding Source may be on a different server (operated by you or a third party) that supports equivalent copying facilities, provided you maintain clear directions next to the object code saying where to find the Corresponding Source. Regardless of what server hosts the Corresponding Source, you remain obligated to ensure that it is available for as long as needed to satisfy these requirements.
- e) Convey the object code using peer-to-peer transmission, provided you inform other peers where the object code and Corresponding Source of the work are being offered to the general public at no charge under subsection 6d. A separable portion of the object code, whose source code is excluded from the Corresponding Source as a System Library, need not be included in conveying the object code work.

A “User Product” is either (1) a “consumer product”, which means any tangible personal property which is normally used for personal, family, or household purposes, or (2) anything designed or sold for incorporation into a dwelling. In determining whether a product is a consumer product, doubtful cases shall be resolved in favor of coverage. For a particular product received by a particular user, “normally used” refers to a typical or common use of that class of product, regardless of the status of the particular user or of the way in which the particular user actually uses, or expects or is expected to use, the product. A product is a consumer product regardless of whether the product has substantial commercial, industrial or non-consumer uses, unless such uses represent the only significant mode of use of the product.

“Installation Information” for a User Product means any methods, procedures, authorization keys, or other information required to install and execute modified versions of a covered work in that User Product from a modified version of its Corresponding Source. The information must suffice to ensure that the continued functioning of the modified object code is in no case prevented or interfered with solely because modification has been made.

If you convey an object code work under this section in, or with, or specifically for use in, a User Product, and the conveying occurs as part of a transaction in which the right of possession and use of the User Product is transferred to the recipient in perpetuity or for a fixed term (regardless of how the transaction is characterized), the Corresponding Source conveyed under this section must be accompanied by the Installation Information. But this requirement does not apply if neither you nor any third party retains the ability to install modified object code on the User Product (for example, the work has been installed in ROM).

The requirement to provide Installation Information does not include a requirement to continue to provide support service, warranty, or updates for a work that has been modified or installed by the recipient, or for the User Product in which it has been modified or installed. Access to a network may be denied when the modification itself materially and adversely affects the operation of the network or violates the rules and protocols for communication across the network.

Corresponding Source conveyed, and Installation Information provided, in accord with this section must be in a format that is publicly documented (and with an implementation available to the public in source code form), and must require no special password or key for unpacking, reading or copying.

7. Additional Terms.

"Additional permissions" are terms that supplement the terms of this License by making exceptions from one or more of its conditions. Additional permissions that are applicable to the entire Program shall be treated as though they were included in this License, to the extent that they are valid under applicable law. If additional permissions apply only to part of the Program, that part may be used separately under those permissions, but the entire Program remains governed by this License without regard to the additional permissions.

When you convey a copy of a covered work, you may at your option remove any additional permissions from that copy, or from any part of it. (Additional permissions may be written to require their own removal in certain cases when you modify the work.) You may place additional permissions on material, added by you to a covered work, for which you have or can give appropriate copyright permission.

Notwithstanding any other provision of this License, for material you add to a covered work, you may (if authorized by the copyright holders of that material) supplement the terms of this License with terms:

- a) Disclaiming warranty or limiting liability differently from the terms of sections 15 and 16 of this License; or
- b) Requiring preservation of specified reasonable legal notices or author attributions in that material or in the Appropriate Legal Notices displayed by works containing it; or
- c) Prohibiting misrepresentation of the origin of that material, or requiring that modified versions of such material be marked in reasonable ways as different from the original version; or
- d) Limiting the use for publicity purposes of names of licensors or authors of the material; or
- e) Declining to grant rights under trademark law for use of some trade names, trademarks, or service marks; or
- f) Requiring indemnification of licensors and authors of that material by anyone who conveys the material (or modified versions of it) with contractual assumptions of liability to the recipient, for any liability that these contractual assumptions directly impose on those licensors and authors.

All other non-permissive additional terms are considered "further restrictions" within the meaning of section 10. If the Program as you received it, or any part of it, contains a notice stating that it is governed by this License along with a term that is a further restriction, you may remove that term. If a license document contains a further restriction but permits relicensing or conveying under this License, you may add to a covered work material governed by the terms of that license document, provided that the further restriction does not survive such relicensing or conveying.

If you add terms to a covered work in accord with this section, you must place, in the relevant source files, a statement of the additional terms that apply to those files, or a notice indicating where to find the applicable terms.

Additional terms, permissive or non-permissive, may be stated in the form of a separately written license, or stated as exceptions; the above requirements apply either way.

8. Termination.

You may not propagate or modify a covered work except as expressly provided under this License. Any attempt otherwise to propagate or modify it is void, and will automatically terminate your rights under this License (including any patent licenses granted under the third paragraph of section 11).

However, if you cease all violation of this License, then your license from a particular copyright holder is reinstated (a) provisionally, unless and until the copyright holder explicitly and finally terminates your license, and (b) permanently, if the copyright holder fails to notify you of the violation by some reasonable means prior to 60 days after the cessation.

Moreover, your license from a particular copyright holder is reinstated permanently if the copyright holder notifies you of the violation by some reasonable means, this is the first time you have received notice of violation of this License (for any work) from that copyright holder, and you cure the violation prior to 30 days after your receipt of the notice.

Termination of your rights under this section does not terminate the licenses of parties who have received copies or rights from you under this License. If your rights have been terminated and not permanently reinstated, you do not qualify to receive new licenses for the same material under section 10.

9. Acceptance Not Required for Having Copies.

You are not required to accept this License in order to receive or run a copy of the Program. Ancillary propagation of a covered work occurring solely as a consequence of using peer-to-peer transmission to receive a copy likewise does not require acceptance. However, nothing other than this License grants you permission to propagate or modify any covered work. These actions infringe copyright if you do not accept this License. Therefore, by modifying or propagating a covered work, you indicate your acceptance of this License to do so.

10. Automatic Licensing of Downstream Recipients.

Each time you convey a covered work, the recipient automatically receives a license from the original licensors, to run, modify and propagate that work, subject to this License. You are not responsible for enforcing compliance by third parties with this License.

An "entity transaction" is a transaction transferring control of an organization, or substantially all assets of one, or subdividing an organization, or merging organizations. If propagation of a covered work results from an entity transaction, each party to that transaction who receives a copy of the work also receives whatever licenses to the work the party's predecessor in interest had or could give under the previous paragraph, plus a right to possession of the Corresponding Source of the work from the predecessor in interest, if the predecessor has it or can get it with reasonable efforts.

You may not impose any further restrictions on the exercise of the rights granted or affirmed under this License. For example, you may not impose a license fee, royalty, or other charge for exercise of rights granted under this License, and you may not initiate litigation (including a cross-claim or counterclaim in a lawsuit) alleging that any patent claim is infringed by making, using, selling, offering for sale, or importing the Program or any portion of it.

11. Patents.

A "contributor" is a copyright holder who authorizes use under this License of the Program or a work on which the Program is based. The work thus licensed is called the contributor's "contributor version".

A contributor's "essential patent claims" are all patent claims owned or controlled by the contributor, whether already acquired or hereafter acquired, that would be infringed by some manner, permitted by this License, of making, using, or selling its contributor version, but do not include claims that would be infringed only as a consequence of further modification of the contributor version. For purposes of this definition, "control" includes the right to grant patent sublicenses in a manner consistent with the requirements of this License.

Each contributor grants you a non-exclusive, worldwide, royalty-free patent license under the contributor's essential patent claims, to make, use, sell, offer for sale, import and otherwise run, modify and propagate the contents of its contributor version. In the following three paragraphs, a "patent license" is any express agreement or commitment, however denominated, not to enforce a patent (such as an express permission to practice a patent or covenant not to sue for patent infringement). To "grant" such a patent license to a party means to make such an agreement or commitment not to enforce a patent against the party.

If you convey a covered work, knowingly relying on a patent license, and the Corresponding Source of the work is not available for anyone to copy, free of charge and under the terms of this License, through a publicly available network server or other readily accessible means, then you must either (1) cause the Corresponding Source to be so available, or (2) arrange to deprive yourself of the benefit of the patent license for this particular work, or (3) arrange, in a manner consistent with the requirements of this License, to extend the patent license to downstream recipients. "Knowingly relying" means you have actual knowledge that, but for the patent license, your conveying the covered work in a country, or your recipient's use of the covered work in a country, would infringe one or more identifiable patents in that country that you have reason to believe are valid.

If, pursuant to or in connection with a single transaction or arrangement, you convey, or propagate by procuring conveyance of, a covered work, and grant a patent license to some of the parties receiving the covered work authorizing them to use, propagate, modify or convey a specific copy of the covered work, then the patent license you grant is automatically extended to all recipients of the covered work and works based on it.

A patent license is "discriminatory" if it does not include within the scope of its coverage, prohibits the exercise of, or is conditioned on the non-exercise of one or more of the rights that are specifically granted under this License. You may not convey a covered work if you are a party to an arrangement with a third party that is in the business of distributing software, under which you make payment to the third party based on the extent of your activity of conveying the work, and under which the third party grants, to any of the parties who would receive the covered work from you, a discriminatory patent license (a) in connection with copies of the covered work conveyed by you (or copies made from those copies), or (b) primarily for and in connection with specific products or compilations that contain the covered work, unless you entered into that arrangement, or that patent license was granted, prior to 28 March 2007.

Nothing in this License shall be construed as excluding or limiting any implied license or other defenses to infringement that may otherwise be available to you under applicable patent law.

12. No Surrender of Others' Freedom.

If conditions are imposed on you (whether by court order, agreement or otherwise) that contradict the conditions of this License, they do not excuse you from the conditions of this License. If you cannot convey a covered work so as to satisfy simultaneously your obligations under this License and any other pertinent obligations, then as a consequence you may not convey it at all. For example, if you agree to terms that obligate you to collect a royalty for further conveying from those to whom you convey the Program, the only way you could satisfy both those terms and this License would be to refrain entirely from conveying the Program.

13. Use with the GNU Affero General Public License.

Notwithstanding any other provision of this License, you have permission to link or combine any covered work with a work licensed under version 3 of the GNU Affero General Public License into a single combined work, and to convey the resulting work. The terms of this License will continue to apply to the part which is the covered work, but the special requirements of the GNU Affero General Public License, section 13, concerning interaction through a network will apply to the combination as such.

14. Revised Versions of this License.

The Free Software Foundation may publish revised and/or new versions of the GNU General Public License from time to time. Such new versions will be similar in spirit to the present version, but may differ in detail to address new problems or concerns. Each version is given a distinguishing version number. If the Program specifies that a certain numbered version of the GNU General Public License “or any later version” applies to it, you have the option of following the terms and conditions either of that numbered version or of any later version published by the Free Software Foundation. If the Program does not specify a version number of the GNU General Public License, you may choose any version ever published by the Free Software Foundation.

If the Program specifies that a proxy can decide which future versions of the GNU General Public License can be used, that proxy’s public statement of acceptance of a version permanently authorizes you to choose that version for the Program.

Later license versions may give you additional or different permissions. However, no additional obligations are imposed on any author or copyright holder as a result of your choosing to follow a later version.

15. Disclaimer of Warranty.

THERE IS NO WARRANTY FOR THE PROGRAM, TO THE EXTENT PERMITTED BY APPLICABLE LAW. EXCEPT WHEN OTHERWISE STATED IN WRITING THE COPYRIGHT HOLDERS AND/OR OTHER PARTIES PROVIDE THE PROGRAM “AS IS” WITHOUT WARRANTY OF ANY KIND, EITHER EXPRESSED OR IMPLIED, INCLUDING, BUT NOT LIMITED TO, THE IMPLIED WARRANTIES OF MERCHANTABILITY AND FITNESS FOR A PARTICULAR PURPOSE. THE ENTIRE RISK AS TO THE QUALITY AND PERFORMANCE OF THE PROGRAM IS WITH YOU. SHOULD THE PROGRAM PROVE DEFECTIVE, YOU ASSUME THE COST OF ALL NECESSARY SERVICING, REPAIR OR CORRECTION.

16. Limitation of Liability.

IN NO EVENT UNLESS REQUIRED BY APPLICABLE LAW OR AGREED TO IN WRITING WILL ANY COPYRIGHT HOLDER, OR ANY OTHER PARTY WHO MODIFIES AND/OR CONVEYS THE PROGRAM AS PERMITTED ABOVE, BE LIABLE TO YOU FOR DAMAGES, INCLUDING ANY GENERAL, SPECIAL, INCIDENTAL OR CONSEQUENTIAL DAMAGES ARISING OUT OF THE USE OR INABILITY TO USE THE PROGRAM (INCLUDING BUT NOT LIMITED TO LOSS OF DATA OR DATA BEING RENDERED INACCURATE OR LOSSES SUSTAINED BY YOU OR THIRD PARTIES OR A FAILURE OF THE PROGRAM TO OPERATE WITH ANY OTHER PROGRAMS), EVEN IF SUCH HOLDER OR OTHER PARTY HAS BEEN ADVISED OF THE POSSIBILITY OF SUCH DAMAGES.

17. Interpretation of Sections 15 and 16.

If the disclaimer of warranty and limitation of liability provided above cannot be given local legal effect according to their terms, reviewing courts shall apply local law that most closely approximates an absolute waiver of all civil liability in connection with the Program, unless a warranty or assumption of liability accompanies a copy of the Program in return for a fee.

END OF TERMS AND CONDITIONS

How to Apply These Terms to Your New Programs

If you develop a new program, and you want it to be of the greatest possible use to the public, the best way to achieve this is to make it free software which everyone can redistribute and change under these terms.

To do so, attach the following notices to the program. It is safest to attach them to the start of each source file to most effectively state the exclusion of warranty; and each file should have at least the “copyright” line and a pointer to where the full notice is found.

<one line to give the program’s name and a brief idea of what it does.> Copyright (C) <year> <name of author>

This program is free software: you can redistribute it and/or modify it under the terms of the GNU General Public License as published by the Free Software Foundation, either version 3 of the License, or (at your option) any later version.

This program is distributed in the hope that it will be useful, but WITHOUT ANY WARRANTY; without even the implied warranty of MERCHANTABILITY or FITNESS FOR A PARTICULAR PURPOSE. See the GNU General Public License for more details.

You should have received a copy of the GNU General Public License along with this program. If not, see <<http://www.gnu.org/licenses/>>.

Also add information on how to contact you by electronic and paper mail.

If the program does terminal interaction, make it output a short notice like this when it starts in an interactive mode:

<program> Copyright (C) <year> <name of author> This program comes with ABSOLUTELY NO WARRANTY; for details type `show w`. This is free software, and you are welcome to redistribute it under certain conditions; type `show c` for details.

The hypothetical commands `show w` and `show c` should show the appropriate parts of the General Public License. Of course, your program’s commands might be different; for a GUI interface, you would use an “about box”.

You should also get your employer (if you work as a programmer) or school, if any, to sign a “copyright disclaimer” for the program, if necessary.

For more information on this, and how to apply and follow the GNU GPL, see <<http://www.gnu.org/licenses/>>.

The GNU General Public License does not permit incorporating your program into proprietary programs. If your program is a subroutine library, you may consider it more useful to permit linking proprietary applications with the library. If this is what you want to do, use the GNU Lesser General Public License instead of this License. But first, please read <<http://www.gnu.org/philosophy/why-not-lgpl.html>>.

GNU Lesser General Public License (LGPL)

Version 3, 29 June 2007

Copyright (C) 2007 Free Software Foundation, Inc. <<http://fsf.org/>>

Everyone is permitted to copy and distribute verbatim copies of this license document, but changing it is not allowed.

Preamble

The GNU General Public License is a free, copyleft license for software and other kinds of works.

The licenses for most software and other practical works are designed to take away your freedom to share and change the works. By contrast, the GNU General Public License is intended to guarantee your freedom to share and change all versions of a program—to make sure it remains free software for all its users. We, the Free Software Foundation, use the GNU General Public License for most of our software; it applies also to any other work released this way by its authors. You can apply it to your programs, too.

When we speak of free software, we are referring to freedom, not price. Our General Public Licenses are designed to make sure that you have the freedom to distribute copies of free software (and charge for them if you wish), that you receive source code or can get it if you want it, that you can change the software or use pieces of it in new free programs, and that you know you can do these things.

To protect your rights, we need to prevent others from denying you these rights or asking you to surrender the rights. Therefore, you have certain responsibilities if you distribute copies of the software, or if you modify it: responsibilities to respect the freedom of others.

For example, if you distribute copies of such a program, whether gratis or for a fee, you must pass on to the recipients the same freedoms that you received. You must make sure that they, too, receive or can get the source code. And you must show them these terms so they know their rights.

Developers that use the GNU GPL protect your rights with two steps: (1) assert copyright on the software, and (2) offer you this License giving you legal permission to copy, distribute and/or modify it.

For the developers' and authors' protection, the GPL clearly explains that there is no warranty for this free software. For both users' and authors' sake, the GPL requires that modified versions be marked as changed, so that their problems will not be attributed erroneously to authors of previous versions.

Some devices are designed to deny users access to install or run modified versions of the software inside them, although the manufacturer can do so. This is fundamentally incompatible with the aim of protecting users' freedom to change the software. The systematic pattern of such abuse occurs in the area of products for individuals to use, which is precisely where it is most unacceptable. Therefore, we have designed this version of the GPL to prohibit the practice for those products. If such problems arise substantially in other domains, we stand ready to extend this provision to those domains in future versions of the GPL, as needed to protect the freedom of users.

Finally, every program is threatened constantly by software patents. States should not allow patents to restrict development and use of software on general-purpose computers, but in those that do, we wish to avoid the special danger that patents applied to a free program could make it effectively proprietary. To prevent this, the GPL assures that patents cannot be used to render the program non-free.

The precise terms and conditions for copying, distribution and modification follow.

TERMS AND CONDITIONS

0. Definitions.

"This License" refers to version 3 of the GNU General Public License.

"Copyright" also means copyright-like laws that apply to other kinds of works, such as semiconductor masks.

"The Program" refers to any copyrightable work licensed under this License. Each licensee is addressed as "you". "Licensees" and "recipients" may be individuals or organizations.

To "modify" a work means to copy from or adapt all or part of the work in a fashion requiring copyright permission, other than the making of an exact copy. The resulting work is called a "modified version" of the earlier work or a work "based on" the earlier work.

A "covered work" means either the unmodified Program or a work based on the Program.

To "propagate" a work means to do anything with it that, without permission, would make you directly or secondarily liable for infringement under applicable copyright law, except executing it on a computer or modifying a private copy. Propagation includes copying, distribution (with or without modification), making available to the public, and in some countries other activities as well.

To "convey" a work means any kind of propagation that enables other parties to make or receive copies. Mere interaction with a user through a computer network, with no transfer of a copy, is not conveying.

An interactive user interface displays "Appropriate Legal Notices" to the extent that it includes a convenient and prominently visible feature that (1) displays an appropriate copyright notice, and (2) tells the user that there is no warranty for the work (except to the extent that warranties are provided), that licensees may convey the work under this License, and how to view a copy of this License. If the interface presents a list of user commands or options, such as a menu, a prominent item in the list meets this criterion.

1. Source Code.

The “source code” for a work means the preferred form of the work for making modifications to it. “Object code” means any non-source form of a work.

A “Standard Interface” means an interface that either is an official standard defined by a recognized standards body, or, in the case of interfaces specified for a particular programming language, one that is widely used among developers working in that language.

The “System Libraries” of an executable work include anything, other than the work as a whole, that (a) is included in the normal form of packaging a Major Component, but which is not part of that Major Component, and (b) serves only to enable use of the work with that Major Component, or to implement a Standard Interface for which an implementation is available to the public in source code form. A “Major Component”, in this context, means a major essential component (kernel, window system, and so on) of the specific operating system (if any) on which the executable work runs, or a compiler used to produce the work, or an object code interpreter used to run it.

The “Corresponding Source” for a work in object code form means all the source code needed to generate, install, and (for an executable work) run the object code and to modify the work, including scripts to control those activities. However, it does not include the work’s System Libraries, or general-purpose tools or generally available free programs which are used unmodified in performing those activities but which are not part of the work. For example, Corresponding Source includes interface definition files associated with source files for the work, and the source code for shared libraries and dynamically linked subprograms that the work is specifically designed to require, such as by intimate data communication or control flow between those subprograms and other parts of the work.

The Corresponding Source need not include anything that users can regenerate automatically from other parts of the Corresponding Source.

The Corresponding Source for a work in source code form is that same work.

2. Basic Permissions.

All rights granted under this License are granted for the term of copyright on the Program, and are irrevocable provided the stated conditions are met. This License explicitly affirms your unlimited permission to run the unmodified Program. The output from running a covered work is covered by this License only if the output, given its content, constitutes a covered work.

This License acknowledges your rights of fair use or other equivalent, as provided by copyright law. You may make, run and propagate covered works that you do not convey, without conditions so long as your license otherwise remains in force. You may convey covered works to others for the sole purpose of having them make modifications exclusively for you, or provide you with facilities for running those works, provided that you comply with the terms of this License in conveying all material for which you do not control copyright. Those thus making or running the covered works for you must do so exclusively on your behalf, under your direction and control, on terms that prohibit them from making any copies of your copyrighted material outside their relationship with you.

Conveying under any other circumstances is permitted solely under the conditions stated below. Sublicensing is not allowed; section 10 makes it unnecessary.

3. Protecting Users’ Legal Rights From Anti-Circumvention Law.

No covered work shall be deemed part of an effective technological measure under any applicable law fulfilling obligations under article 11 of the WIPO copyright treaty adopted on 20 December 1996, or similar laws prohibiting or restricting circumvention of such measures.

When you convey a covered work, you waive any legal power to forbid circumvention of technological measures to the extent such circumvention is effected by exercising rights under this License with respect to the covered work, and you disclaim any intention to limit operation or modification of the work as a means of enforcing, against the work’s users, your or third parties’ legal rights to forbid circumvention of technological measures.

4. Conveying Verbatim Copies.

You may convey verbatim copies of the Program’s source code as you receive it, in any medium, provided that you conspicuously and appropriately publish on each copy an appropriate copyright notice; keep intact all notices stating that this License and any non-permissive terms added in accord with section 7 apply to the code; keep intact all notices of the absence of any warranty; and give all recipients a copy of this License along with the Program.

You may charge any price or no price for each copy that you convey, and you may offer support or warranty protection for a fee.

5. Conveying Modified Source Versions.

You may convey a work based on the Program, or the modifications to produce it from the Program, in the form of source code under the terms of section 4, provided that you also meet all of these conditions:

- a) The work must carry prominent notices stating that you modified it, and giving a relevant date.
- b) The work must carry prominent notices stating that it is released under this License and any conditions added under section 7. This requirement modifies the requirement in section 4 to “keep intact all notices”.
- c) You must license the entire work, as a whole, under this License to anyone who comes into possession of a copy. This License will therefore apply, along with any applicable section 7 additional terms, to the whole of the work, and all its parts, regardless of how they are packaged. This License gives no permission to license the work in any other way, but it does not invalidate such permission if you have separately received it.
- d) If the work has interactive user interfaces, each must display Appropriate Legal Notices; however, if the Program has interactive interfaces that do not display Appropriate Legal Notices, your work need not make them do so.

A compilation of a covered work with other separate and independent works, which are not by their nature extensions of the covered work, and which are not combined with it such as to form a larger program, in or on a volume of a storage or distribution medium, is called an "aggregate" if the compilation and its resulting copyright are not used to limit the access or legal rights of the compilation's users beyond what the individual works permit. Inclusion of a covered work in an aggregate does not cause this License to apply to the other parts of the aggregate.

6. Conveying Non-Source Forms.

You may convey a covered work in object code form under the terms of sections 4 and 5, provided that you also convey the machine-readable Corresponding Source under the terms of this License, in one of these ways:

- a) Convey the object code in, or embodied in, a physical product (including a physical distribution medium), accompanied by the Corresponding Source fixed on a durable physical medium customarily used for software interchange.
- b) Convey the object code in, or embodied in, a physical product (including a physical distribution medium), accompanied by a written offer, valid for at least three years and valid for as long as you offer spare parts or customer support for that product model, to give anyone who possesses the object code either (1) a copy of the Corresponding Source for all the software in the product that is covered by this License, on a durable physical medium customarily used for software interchange, for a price no more than your reasonable cost of physically performing this conveying of source, or (2) access to copy the Corresponding Source from a network server at no charge.
- c) Convey individual copies of the object code with a copy of the written offer to provide the Corresponding Source. This alternative is allowed only occasionally and noncommercially, and only if you received the object code with such an offer, in accord with subsection 6b.
- d) Convey the object code by offering access from a designated place (gratis or for a charge), and offer equivalent access to the Corresponding Source in the same way through the same place at no further charge. You need not require recipients to copy the Corresponding Source along with the object code. If the place to copy the object code is a network server, the Corresponding Source may be on a different server (operated by you or a third party) that supports equivalent copying facilities, provided you maintain clear directions next to the object code saying where to find the Corresponding Source. Regardless of what server hosts the Corresponding Source, you remain obligated to ensure that it is available for as long as needed to satisfy these requirements.
- e) Convey the object code using peer-to-peer transmission, provided you inform other peers where the object code and Corresponding Source of the work are being offered to the general public at no charge under subsection 6d. A separable portion of the object code, whose source code is excluded from the Corresponding Source as a System Library, need not be included in conveying the object code work.

A "User Product" is either (1) a "consumer product", which means any tangible personal property which is normally used for personal, family, or household purposes, or (2) anything designed or sold for incorporation into a dwelling. In determining whether a product is a consumer product, doubtful cases shall be resolved in favor of coverage. For a particular product received by a particular user, "normally used" refers to a typical or common use of that class of product, regardless of the status of the particular user or of the way in which the particular user actually uses, or expects or is expected to use, the product. A product is a consumer product regardless of whether the product has substantial commercial, industrial or non-consumer uses, unless such uses represent the only significant mode of use of the product.

"Installation Information" for a User Product means any methods, procedures, authorization keys, or other information required to install and execute modified versions of a covered work in that User Product from a modified version of its Corresponding Source. The information must suffice to ensure that the continued functioning of the modified object code is in no case prevented or interfered with solely because modification has been made.

If you convey an object code work under this section in, or with, or specifically for use in, a User Product, and the conveying occurs as part of a transaction in which the right of possession and use of the User Product is transferred to the recipient in perpetuity or for a fixed term (regardless of how the transaction is characterized), the Corresponding Source conveyed under this section must be accompanied by the Installation Information. But this requirement does not apply if neither you nor any third party retains the ability to install modified object code on the User Product (for example, the work has been installed in ROM).

The requirement to provide Installation Information does not include a requirement to continue to provide support service, warranty, or updates for a work that has been modified or installed by the recipient, or for the User Product in which it has been modified or installed. Access to a network may be denied when the modification itself materially and adversely affects the operation of the network or violates the rules and protocols for communication across the network.

Corresponding Source conveyed, and Installation Information provided, in accord with this section must be in a format that is publicly documented (and with an implementation available to the public in source code form), and must require no special password or key for unpacking, reading or copying.

7. Additional Terms.

"Additional permissions" are terms that supplement the terms of this License by making exceptions from one or more of its conditions. Additional permissions that are applicable to the entire Program shall be treated as though they were included in this License, to the extent that they are valid under applicable law. If additional permissions apply only to part of the Program, that part may be used separately under those permissions, but the entire Program remains governed by this License without regard to the additional permissions.

When you convey a copy of a covered work, you may at your option remove any additional permissions from that copy, or from any part of it. (Additional permissions may be written to require their own removal in certain cases when you modify the work.) You may place additional permissions on material, added by you to a covered work, for which you have or can give appropriate copyright permission.

Notwithstanding any other provision of this License, for material you add to a covered work, you may (if authorized by the copyright holders of that material) supplement the terms of this License with terms:

- a) Disclaiming warranty or limiting liability differently from the terms of sections 15 and 16 of this License; or
- b) Requiring preservation of specified reasonable legal notices or author attributions in that material or in the Appropriate Legal Notices displayed by works containing it; or
- c) Prohibiting misrepresentation of the origin of that material, or requiring that modified versions of such material be marked in reasonable ways as different from the original version; or
- d) Limiting the use for publicity purposes of names of licensors or authors of the material; or
- e) Declining to grant rights under trademark law for use of some trade names, trademarks, or service marks; or
- f) Requiring indemnification of licensors and authors of that material by anyone who conveys the material (or modified versions of it) with contractual assumptions of liability to the recipient, for any liability that these contractual assumptions directly impose on those licensors and authors.

All other non-permissive additional terms are considered “further restrictions” within the meaning of section 10. If the Program as you received it, or any part of it, contains a notice stating that it is governed by this License along with a term that is a further restriction, you may remove that term. If a license document contains a further restriction but permits relicensing or conveying under this License, you may add to a covered work material governed by the terms of that license document, provided that the further restriction does not survive such relicensing or conveying.

If you add terms to a covered work in accord with this section, you must place, in the relevant source files, a statement of the additional terms that apply to those files, or a notice indicating where to find the applicable terms.

Additional terms, permissive or non-permissive, may be stated in the form of a separately written license, or stated as exceptions; the above requirements apply either way.

8. Termination.

You may not propagate or modify a covered work except as expressly provided under this License. Any attempt otherwise to propagate or modify it is void, and will automatically terminate your rights under this License (including any patent licenses granted under the third paragraph of section 11).

However, if you cease all violation of this License, then your license from a particular copyright holder is reinstated (a) provisionally, unless and until the copyright holder explicitly and finally terminates your license, and (b) permanently, if the copyright holder fails to notify you of the violation by some reasonable means prior to 60 days after the cessation.

Moreover, your license from a particular copyright holder is reinstated permanently if the copyright holder notifies you of the violation by some reasonable means, this is the first time you have received notice of violation of this License (for any work) from that copyright holder, and you cure the violation prior to 30 days after your receipt of the notice.

Termination of your rights under this section does not terminate the licenses of parties who have received copies or rights from you under this License. If your rights have been terminated and not permanently reinstated, you do not qualify to receive new licenses for the same material under section 10.

9. Acceptance Not Required for Having Copies.

You are not required to accept this License in order to receive or run a copy of the Program. Ancillary propagation of a covered work occurring solely as a consequence of using peer-to-peer transmission to receive a copy likewise does not require acceptance. However, nothing other than this License grants you permission to propagate or modify any covered work. These actions infringe copyright if you do not accept this License. Therefore, by modifying or propagating a covered work, you indicate your acceptance of this License to do so.

10. Automatic Licensing of Downstream Recipients.

Each time you convey a covered work, the recipient automatically receives a license from the original licensors, to run, modify and propagate that work, subject to this License. You are not responsible for enforcing compliance by third parties with this License.

An “entity transaction” is a transaction transferring control of an organization, or substantially all assets of one, or subdividing an organization, or merging organizations. If propagation of a covered work results from an entity transaction, each party to that transaction who receives a copy of the work also receives whatever licenses to the work the party’s predecessor in interest had or could give under the previous paragraph, plus a right to possession of the Corresponding Source of the work from the predecessor in interest, if the predecessor has it or can get it with reasonable efforts.

You may not impose any further restrictions on the exercise of the rights granted or affirmed under this License. For example, you may not impose a license fee, royalty, or other charge for exercise of rights granted under this License, and you may not initiate litigation (including a cross-claim or counterclaim in a lawsuit) alleging that any patent claim is infringed by making, using, selling, offering for sale, or importing the Program or any portion of it.

11. Patents.

A “contributor” is a copyright holder who authorizes use under this License of the Program or a work on which the Program is based. The work thus licensed is called the contributor’s “contributor version”.

A contributor’s “essential patent claims” are all patent claims owned or controlled by the contributor, whether already acquired or hereafter acquired, that would be infringed by some manner, permitted by this License, of making, using, or selling its contributor version, but do not include claims that would be infringed only as a consequence of further modification of the contributor version. For purposes of this definition, “control” includes the right to grant patent sublicenses in a manner consistent with the requirements of this License.

Each contributor grants you a non-exclusive, worldwide, royalty-free patent license under the contributor’s essential patent claims, to make, use, sell, offer for sale, import and otherwise run, modify and propagate the contents of its contributor version. In the following three paragraphs, a “patent license” is any express agreement or commitment, however denominated, not to enforce a patent (such as an express permission to practice a patent or covenant not to sue for patent infringement). To “grant” such a patent license to a party means to make such an agreement or commitment not to enforce a patent against the party.

If you convey a covered work, knowingly relying on a patent license, and the Corresponding Source of the work is not available for anyone to copy, free of charge and under the terms of this License, through a publicly available network server or other readily accessible means, then you must either (1) cause the Corresponding Source to be so available, or (2) arrange to deprive yourself of the benefit of the patent license for this particular work, or (3) arrange, in a manner consistent with the requirements of this License, to extend the patent license to downstream recipients. “Knowingly relying” means you have actual knowledge that, but for the patent license, your conveying the covered work in a country, or your recipient’s use of the covered work in a country, would infringe one or more identifiable patents in that country that you have reason to believe are valid.

If, pursuant to or in connection with a single transaction or arrangement, you convey, or propagate by procuring conveyance of, a covered work, and grant a patent license to some of the parties receiving the covered work authorizing them to use, propagate, modify or convey a specific copy of the covered work, then the patent license you grant is automatically extended to all recipients of the covered work and works based on it.

A patent license is “discriminatory” if it does not include within the scope of its coverage, prohibits the exercise of, or is conditioned on the non-exercise of one or more of the rights that are specifically granted under this License. You may not convey a covered work if you are a party to an arrangement with a third party that is in the business of distributing software, under which you make payment to the third party based on the extent of your activity of conveying the work, and under which the third party grants, to any of the parties who would receive the covered work from you, a discriminatory patent license (a) in connection with copies of the covered work conveyed by you (or copies made from those copies), or (b) primarily for and in connection with specific products or compilations that contain the covered work, unless you entered into that arrangement, or that patent license was granted, prior to 28 March 2007.

Nothing in this License shall be construed as excluding or limiting any implied license or other defenses to infringement that may otherwise be available to you under applicable patent law.

12. No Surrender of Others’ Freedom.

If conditions are imposed on you (whether by court order, agreement or otherwise) that contradict the conditions of this License, they do not excuse you from the conditions of this License. If you cannot convey a covered work so as to satisfy simultaneously your obligations under this License and any other pertinent obligations, then as a consequence you may not convey it at all. For example, if you agree to terms that obligate you to collect a royalty for further conveying from those to whom you convey the Program, the only way you could satisfy both those terms and this License would be to refrain entirely from conveying the Program.

13. Use with the GNU Affero General Public License.

Notwithstanding any other provision of this License, you have permission to link or combine any covered work with a work licensed under version 3 of the GNU Affero General Public License into a single combined work, and to convey the resulting work. The terms of this License will continue to apply to the part which is the covered work, but the special requirements of the GNU Affero General Public License, section 13, concerning interaction through a network will apply to the combination as such.

14. Revised Versions of this License.

The Free Software Foundation may publish revised and/or new versions of the GNU General Public License from time to time. Such new versions will be similar in spirit to the present version, but may differ in detail to address new problems or concerns.

Each version is given a distinguishing version number. If the Program specifies that a certain numbered version of the GNU General Public License “or any later version” applies to it, you have the option of following the terms and conditions either of that numbered version or of any later version published by the Free Software Foundation. If the Program does not specify a version number of the GNU General Public License, you may choose any version ever published by the Free Software Foundation.

If the Program specifies that a proxy can decide which future versions of the GNU General Public License can be used, that proxy’s public statement of acceptance of a version permanently authorizes you to choose that version for the Program. Later license versions may give you additional or different permissions. However, no additional obligations are imposed on any author or copyright holder as a result of your choosing to follow a later version.

15. Disclaimer of Warranty.

THERE IS NO WARRANTY FOR THE PROGRAM, TO THE EXTENT PERMITTED BY APPLICABLE LAW. EXCEPT WHEN OTHERWISE STATED IN WRITING THE COPYRIGHT HOLDERS AND/OR OTHER PARTIES PROVIDE THE PROGRAM "AS IS" WITHOUT WARRANTY OF ANY KIND, EITHER EXPRESSED OR IMPLIED, INCLUDING, BUT NOT LIMITED TO, THE IMPLIED WARRANTIES OF MERCHANTABILITY AND FITNESS FOR A PARTICULAR PURPOSE. THE ENTIRE RISK AS TO THE QUALITY AND PERFORMANCE OF THE PROGRAM IS WITH YOU. SHOULD THE PROGRAM PROVE DEFECTIVE, YOU ASSUME THE COST OF ALL NECESSARY SERVICING, REPAIR OR CORRECTION.

16. Limitation of Liability.

IN NO EVENT UNLESS REQUIRED BY APPLICABLE LAW OR AGREED TO IN WRITING WILL ANY COPYRIGHT HOLDER, OR ANY OTHER PARTY WHO MODIFIES AND/OR CONVEYS THE PROGRAM AS PERMITTED ABOVE, BE LIABLE TO YOU FOR DAMAGES, INCLUDING ANY GENERAL, SPECIAL, INCIDENTAL OR CONSEQUENTIAL DAMAGES ARISING OUT OF THE USE OR INABILITY TO USE THE PROGRAM (INCLUDING BUT NOT LIMITED TO LOSS OF DATA OR DATA BEING RENDERED INACCURATE OR LOSSES SUSTAINED BY YOU OR THIRD PARTIES OR A FAILURE OF THE PROGRAM TO OPERATE WITH ANY OTHER PROGRAMS), EVEN IF SUCH HOLDER OR OTHER PARTY HAS BEEN ADVISED OF THE POSSIBILITY OF SUCH DAMAGES.

17. Interpretation of Sections 15 and 16.

If the disclaimer of warranty and limitation of liability provided above cannot be given local legal effect according to their terms, reviewing courts shall apply local law that most closely approximates an absolute waiver of all civil liability in connection with the Program, unless a warranty or assumption of liability accompanies a copy of the Program in return for a fee.

END OF TERMS AND CONDITIONS

How to Apply These Terms to Your New Programs

If you develop a new program, and you want it to be of the greatest possible use to the public, the best way to achieve this is to make it free software which everyone can redistribute and change under these terms.

To do so, attach the following notices to the program. It is safest to attach them to the start of each source file to most effectively state the exclusion of warranty; and each file should have at least the "copyright" line and a pointer to where the full notice is found.

<one line to give the program's name and a brief idea of what it does.> Copyright (C) <year> <name of author>

This program is free software: you can redistribute it and/or modify it under the terms of the GNU General Public License as published by the Free Software Foundation, either version 3 of the License, or (at your option) any later version.

This program is distributed in the hope that it will be useful, but WITHOUT ANY WARRANTY; without even the implied warranty of MERCHANTABILITY or FITNESS FOR A PARTICULAR PURPOSE. See the GNU General Public License for more details.

You should have received a copy of the GNU General Public License along with this program. If not, see <<http://www.gnu.org/licenses/>>.

Also add information on how to contact you by electronic and paper mail.

If the program does terminal interaction, make it output a short notice like this when it starts in an interactive mode:

<program> Copyright (C) <year> <name of author> This program comes with ABSOLUTELY NO WARRANTY; for details type `show w'. This is free software, and you are welcome to redistribute it under certain conditions; type `show c' for details.

The hypothetical commands `show w' and `show c' should show the appropriate parts of the General Public License. Of course, your program's commands might be different; for a GUI interface, you would use an "about box".

You should also get your employer (if you work as a programmer) or school, if any, to sign a "copyright disclaimer" for the program, if necessary.

For more information on this, and how to apply and follow the GNU GPL, see <<http://www.gnu.org/licenses/>>.

The GNU General Public License does not permit incorporating your program into proprietary programs. If your program is a subroutine library, you may consider it more useful to permit linking proprietary applications with the library. If this is what you want to do, use the GNU Lesser General Public License instead of this License. But first, please read <<http://www.gnu.org/philosophy/why-not-lgpl.html>>.

LICENSE ISSUES

The OpenSSL toolkit stays under a dual license, i.e. both the conditions of the OpenSSL License and the original SSLeay license apply to the toolkit. See below for the actual license texts. Actually both licenses are BSD-style Open Source licenses. In case of any license issues related to OpenSSL please contact openssl-core@openssl.org.

OpenSSL License

Copyright (c) 1998-2007 The OpenSSL Project. All rights reserved.

Redistribution and use in source and binary forms, with or without modification, are permitted provided that the following conditions are met:

1. Redistributions of source code must retain the above copyright notice, this list of conditions and the following disclaimer.
2. Redistributions in binary form must reproduce the above copyright notice, this list of conditions and the following disclaimer in the documentation and/or other materials provided with the distribution.
3. All advertising materials mentioning features or use of this software must display the following acknowledgment: "This product includes software developed by the OpenSSL Project for use in the OpenSSL Toolkit. (<http://www.openssl.org/>)"
4. The names "OpenSSL Toolkit" and "OpenSSL Project" must not be used to endorse or promote products derived from this software without prior written permission. For written permission, please contact openssl-core@openssl.org.
5. Products derived from this software may not be called "OpenSSL" nor may "OpenSSL" appear in their names without prior written permission of the OpenSSL Project.
6. Redistributions of any form whatsoever must retain the following acknowledgment: "This product includes software developed by the OpenSSL Project for use in the OpenSSL Toolkit (<http://www.openssl.org/>)"

THIS SOFTWARE IS PROVIDED BY THE OpenSSL PROJECT ``AS IS'' AND ANY EXPRESSED OR IMPLIED WARRANTIES, INCLUDING, BUT NOT LIMITED TO, THE IMPLIED WARRANTIES OF MERCHANTABILITY AND FITNESS FOR A PARTICULAR PURPOSE ARE DISCLAIMED. IN NO EVENT SHALL THE OpenSSL PROJECT OR ITS CONTRIBUTORS BE LIABLE FOR ANY DIRECT, INDIRECT, INCIDENTAL, SPECIAL, EXEMPLARY, OR CONSEQUENTIAL DAMAGES (INCLUDING, BUT NOT LIMITED TO, PROCUREMENT OF SUBSTITUTE GOODS OR SERVICES; LOSS OF USE, DATA, OR PROFITS; OR BUSINESS INTERRUPTION) HOWEVER CAUSED AND ON ANY THEORY OF LIABILITY, WHETHER IN CONTRACT, STRICT LIABILITY, OR TORT (INCLUDING NEGLIGENCE OR OTHERWISE) ARISING IN ANY WAY OUT OF THE USE OF THIS SOFTWARE, EVEN IF ADVISED OF THE POSSIBILITY OF SUCH DAMAGE.

This product includes cryptographic software written by Eric Young (ey@cryptsoft.com). This product includes software written by Tim Hudson (tjh@cryptsoft.com).

Original SSLeay License

Copyright (C) 1995-1998 Eric Young (ey@cryptsoft.com) All rights reserved.

This package is an SSL implementation written by Eric Young (ey@cryptsoft.com). The implementation was written so as to conform with Netscapes SSL.

This library is free for commercial and non-commercial use as long as the following conditions are aheared to. The following conditions apply to all code found in this distribution, be it the RC4, RSA, lhash, DES, etc., code; not just the SSL code. The SSL documentation included with this distribution is covered by the same copyright terms except that the holder is Tim Hudson (tjh@cryptsoft.com).

Copyright remains Eric Young's, and as such any Copyright notices in the code are not to be removed. If this package is used in a product, Eric Young should be given attribution as the author of the parts of the library used. This can be in the form of a textual message at program startup or in documentation (online or textual) provided with the package.

Redistribution and use in source and binary forms, with or without modification, are permitted provided that the following conditions are met:

1. Redistributions of source code must retain the copyright notice, this list of conditions and the following disclaimer.
2. Redistributions in binary form must reproduce the above copyright notice, this list of conditions and the following disclaimer in the documentation and/or other materials provided with the distribution.
3. All advertising materials mentioning features or use of this software must display the following acknowledgement: "This product includes cryptographic software written by Eric Young (ey@cryptsoft.com)" The word 'cryptographic' can be left out if the rouines from the library being used are not cryptographic related :-).
4. If you include any Windows specific code (or a derivative thereof) from the apps directory (application code) you must include an acknowledgement: "This product includes software written by Tim Hudson (tjh@cryptsoft.com)"

THIS SOFTWARE IS PROVIDED BY ERIC YOUNG ``AS IS'' AND ANY EXPRESS OR IMPLIED WARRANTIES, INCLUDING, BUT NOT LIMITED TO, THE IMPLIED WARRANTIES OF MERCHANTABILITY AND FITNESS FOR A PARTICULAR PURPOSE ARE DISCLAIMED. IN NO EVENT SHALL THE AUTHOR OR CONTRIBUTORS BE LIABLE FOR ANY DIRECT, INDIRECT, INCIDENTAL, SPECIAL, EXEMPLARY, OR CONSEQUENTIAL DAMAGES (INCLUDING, BUT NOT LIMITED TO, PROCUREMENT OF SUBSTITUTE GOODS OR SERVICES; LOSS OF USE, DATA, OR PROFITS; OR BUSINESS INTERRUPTION) HOWEVER CAUSED AND ON ANY THEORY OF LIABILITY, WHETHER IN CONTRACT, STRICT LIABILITY, OR TORT (INCLUDING NEGLIGENCE OR OTHERWISE) ARISING IN ANY WAY OUT OF THE USE OF THIS SOFTWARE, EVEN IF ADVISED OF THE POSSIBILITY OF SUCH DAMAGE.

The licence and distribution terms for any publically available version or derivative of this code cannot be changed. i.e. this code cannot simply be copied and put under another distribution licence [including the GNU Public Licence.]



Correct Disposal of This Product (Waste Electrical & Electronic Equipment)

(Applicable in the European Union and other European countries with separate collection systems) This marking on the product, accessories or literature indicates that the product and its electronic accessories (e.g. charger, headset, USB cable) should not be disposed of with other household waste at the end of their working life. To prevent possible harm to the environment or human health from uncontrolled waste disposal, please separate these items from other types of waste and recycle them responsibly to promote the sustainable reuse of material resources. Household users should contact either the retailer where they purchased this product, or their local government office, for details of where and how they can take these items for environmentally safe recycling. Business users should contact their supplier and check the terms and conditions of the purchase contract. This product and its electronic accessories should not be mixed with other commercial wastes for disposal.

[English]



Les bons gestes de mise au rebut de ce produit (Déchets d'équipements électriques et électroniques)

(Applicable dans les pays de l'Union Européenne et dans d'autres pays européens pratiquant le tri sélectif)

Ce symbole sur le produit, ses accessoires ou sa documentation indique que ni le produit, ni ses accessoires électroniques usagés (chargeur, casque audio, câble USB, etc.) ne peuvent être jetés avec les autres déchets ménagers. La mise au rebut incontrôlée des déchets présentant des risques environnementaux et de santé publique, veuillez séparer vos produits et accessoires usagés des autres déchets. Vous favoriserez ainsi le recyclage de la matière qui les compose dans le cadre d'un développement durable. Les particuliers sont invités à contacter le magasin ayant vendu le produit ou à se renseigner auprès des autorités locales pour connaître les procédures et les points de collecte de ces produits en vue de leur recyclage. Les entreprises et professionnels sont invités à contacter leurs fournisseurs et à consulter les conditions de leur contrat de vente. Ce produit et ses accessoires ne peuvent être jetés avec les autres déchets professionnels et commerciaux.

[Français]



Korrekte Entsorgung von Altgeräten (Elektroschrott)

(In den Ländern der Europäischen Union und anderen europäischen Ländern mit einem separaten Sammelsystem)

Die Kennzeichnung auf dem Produkt, Zubehörteilen bzw. auf der dazugehörigen Dokumentation gibt an, dass das Produkt und Zubehörteile (z. B. Ladegerät, Kopfhörer, USB-Kabel) nach ihrer Lebensdauer nicht zusammen mit dem normalen Haushaltsmüll entsorgt werden dürfen. Entsorgen Sie dieses Gerät und Zubehörteile bitte getrennt von anderen Abfällen, um der Umwelt bzw. der menschlichen Gesundheit nicht durch unkontrollierte Müllbeseitigung zu schaden. Helfen Sie mit, das Altgerät und Zubehörteile fachgerecht zu entsorgen, um die nachhaltige Wiederverwertung von stofflichen Ressourcen zu fördern. Private Nutzer wenden sich an den Händler, bei dem das Produkt gekauft wurde, oder kontaktieren die zuständigen Behörden, um in Erfahrung zu bringen, wo Sie das Altgerät bzw. Zubehörteile für eine umweltfreundliche Entsorgung abgeben können. Gewerbliche Nutzer wenden sich an ihren Lieferanten und gehen nach den Bedingungen des Kaufvertrags vor. Dieses Produkt und elektronische Zubehörteile dürfen nicht zusammen mit anderem Gewerbemüll entsorgt werden.

[Deutsch]



Correcte verwijdering van dit product (elektrische & elektronische afvalapparatuur)

Dit merkteken op het product, de accessoires of het informatiemateriaal duidt erop dat het product en zijn elektronische accessoires (bv. lader, headset, USB-kabel) niet met ander huishoudelijk afval verwijderd mogen worden aan het einde van hun gebruiksduur. Om mogelijke schade aan het milieu of de menselijke gezondheid door ongecontroleerde afvalverwijdering te voorkomen, moet u deze artikelen van andere soorten afval scheiden en op een verantwoorde manier recyclen, zodat het duurzame hergebruik van materiaalbronnen wordt bevorderd. Huishoudelijke gebruikers moeten contact opnemen met de winkel waar ze dit product hebben gekocht of met de gemeente waar ze wonen om te vernemen waar en hoe ze deze artikelen milieuvriendelijk kunnen laten recyclen. Zakelijke gebruikers moeten contact opnemen met hun leverancier en de algemene voorwaarden van de koopovereenkomst nalezen. Dit product en zijn elektronische accessoires mogen niet met ander bedrijfsafval voor verwijdering worden gemengd.

[Nederlands]



Corretto smaltimento del prodotto (rifiuti elettrici ed elettronici)

(Applicabile nell'Unione Europea e in altri paesi europei con sistema di raccolta differenziata)

Il marchio riportato sul prodotto, sugli accessori o sulla documentazione indica che il prodotto e i relativi accessori elettronici (quali caricabatterie, cuffia e cavo USB) non devono essere smaltiti con altri rifiuti domestici al termine del ciclo di vita. Per evitare eventuali danni all'ambiente o alla salute causati dall'inopportuno smaltimento dei rifiuti, si invita l'utente a separare il prodotto e i suddetti accessori da altri tipi di rifiuti e di riciclarli in maniera responsabile per favorire il riutilizzo sostenibile delle risorse materiali. Gli utenti domestici sono invitati a contattare il rivenditore presso il quale è stato acquistato il prodotto o l'ufficio locale preposto per tutte le informazioni relative alla raccolta differenziata e al riciclaggio per questo tipo di materiali. Gli utenti aziendali sono invitati a contattare il proprio fornitore e verificare i termini e le condizioni del contratto di acquisto. Questo prodotto e i relativi accessori elettronici non devono essere smaltiti unitamente ad altri rifiuti commerciali.

[Italiano]



Eliminación correcta de este producto (Residuos de aparatos eléctricos y electrónicos)

(Aplicable en la Unión Europea y en países europeos con sistemas de recogida selectiva de residuos)

La presencia de este símbolo en el producto, accesorios o material informativo que lo acompañan, indica que al finalizar su vida útil ni el producto ni sus accesorios electrónicos (como el cargador, cascos, cable USB) deberán eliminarse junto con otros residuos domésticos. Para evitar los posibles daños al medio ambiente o a la salud humana que representa la eliminación incontrolada de residuos, separe estos productos de otros tipos de residuos y recícelos correctamente. De esta forma se promueve la reutilización sostenible de recursos materiales. Los usuarios particulares pueden contactar con el establecimiento donde adquirieron el producto o con las autoridades locales pertinentes para informarse sobre cómo y dónde pueden llevarlo para que sea sometido a un reciclaje ecológico y seguro. Los usuarios comerciales pueden contactar con su proveedor y consultar las condiciones del contrato de compra. Este producto y sus accesorios electrónicos no deben eliminarse junto a otros residuos comerciales.

[Español]



Eliminação Correcta Deste Produto (Resíduos de Equipamentos Eléctricos e Electrónicos)

Esta marca apresentada no produto, nos acessórios ou na literatura – indica que o produto e os seus acessórios electrónicos (por exemplo, o carregador, o auricular, o cabo USB) não deverão ser eliminados juntamente com os resíduos domésticos no final do seu período de vida útil. Para impedir danos ao ambiente ou à saúde humana causados pela eliminação incontrolada de resíduos, deverá separar estes equipamentos de outros tipos de resíduos e reciclá-los de forma responsável, para promover uma reutilização sustentável dos recursos materiais. Os utilizadores domésticos deverão contactar o estabelecimento onde adquiriram este produto ou as entidades oficiais locais para obterem informações sobre onde e de que forma podem entregar estes equipamentos para permitir efectuar uma reciclagem segura em termos ambientais. Os utilizadores profissionais deverão contactar o seu fornecedor e consultar os termos e condições do contrato de compra. Este produto e os seus acessórios electrónicos não deverão ser misturados com outros resíduos comerciais para eliminação.

[Português]



Korrekt avfallshandtering av produkten (elektriska och elektroniska produkter)

Denna markering på produkten, tillbehören och i manualen anger att produkten och de elektroniska tillbehören (t.ex. laddare, headset, USB-kabel) inte bör sorteras tillsammans med annat hushållsavfall när de kasseras. Till förebyggande av skada på miljö och hälsa bör dessa föremål hanteras separat för ändamålsenlig återvinning av beståndsdelarna. Hushållsanvändare bör kontakta den återförsljäre som sålt produkten eller sin kommun för vidare information om var och hur produkten och tillbehören kan återvinnas på ett miljösäkert sätt. Företagsanvändare bör kontakta leverantören samt verifiera angivna villkor i köpekontraktet. Produkten och de elektroniska tillbehören bör inte hanteras tillsammans med annat kommersiellt avfall.

[Svenska]



Korrekt affaldsbortskaffelse af dette produkt (elektrisk & elektronisk udstyr)

Mærket på dette produkt, på tilbehør eller i den medfølgende dokumentation betyder, at produktet og elektronisk tilbehør hertil (f.eks. oplader, hovedsæt, USB-ledning) ikke må bortskaffes sammen med almindeligt husholdningsaffald efter endt levetid. For at undgå skadelige miljø- eller sundhedspåvirkninger på grund af ukontrolleret affaldsbortskaffelse skal ovennævnte bortskaffes særskilt fra andet affald og indleveres behørigt til fremme for bæredygtig materialegenvinding. Forbrugere bedes kontakte forhandleren, hvor de har købt produktet, eller kommunen for oplysning om, hvor og hvordan de kan indlevere ovennævnte med henblik på miljøforsvarlig genvinding. Virksomheder bedes kontakte leverandøren og læse betingelserne og vilkårene i købekontrakten. Dette produkt og elektronisk tilbehør hertil bør ikke bortskaffes sammen med andet erhvervsaffald.

[Dansk]



Korrekt avhending av dette produktet (Avfall fra elektrisk og elektronisk utstyr)

Denne merkingen som vises på produktet, dets tilbehør eller dokumentasjon, indikerer at produktet eller det elektroniske tilbehøret (for eksempel lader, headset, USB-kabel) ikke skal kastes sammen med annet husholdningsavfall ved slutten av levetiden. For å hindre potensiell skade på miljøet eller helseskader grunnet ukontrollert avfallsavhending ber vi om at dette avfallet holdes adskilt fra andre typer avfall og resirkuleres på ansvarlig måte for å fremme bærekraftig gjenbruk av materielle ressurser. Private forbrukere bør kontakte enten forhandleren de kjøpte produktet av, eller lokale myndigheter, for detaljer om hvor og hvordan disse artiklene kan resirkuleres på en miljøvennlig måte. Forretningsbrukere bør kontakte sin leverandør og undersøke vilkårene i kjøpskontrakten. Dette produktet og det elektroniske tilbehøret skal ikke blandes med annet kommersielt avfall som skal kastes.

[Norsk]



Tuoteen turvallinen hävittäminen (elektroniikka ja sähkölaitteet)

Oheinen merkintä tuotteessa, lisävarusteissa tai käyttöohjeessa merkitsee, että tuotetta tai lisävarusteina toimitettavia sähkölaitteita (esim. laturia, kuulokkeita tai USB kaapelia) ei saa hävittää kotitalousjätteen mukana niiden käyttöiän päätyttyä. Virheellisesti jätteenkäsittelystä ympäristölle ja terveydelle aiheutuvien haittojen välttämiseksi tuote ja lisävarusteet on eroteltava muusta jätteestä ja kierrätettävä kestävä kehityksen mukaista uusiokäyttöä varten. Kotikäyttäjät saavat lisätietoja tuotteen ja lisävarusteiden turvallisesta kierrätyksestä ottamalla yhteyttä tuotteen myyneeseen jälleenmyyjään tai paikalliseen ympäristöviranomaiseen. Yrityskäyttäjien tulee ottaa yhteyttä tavarantoimittajaan ja selvittää hankintasopimuksen ehdot. Tuotetta tai sen lisävarusteita ei saa hävittää muun kaupallisen jätteen seassa.

[Suomi]



A termék hulladékba helyezésének módszere(WEEE – Elektromos és elektronikus berendezések hulladékai)

Ez a jelzés a terméken, tartozékain vagy dokumentációján arra utal, hogy hasznos élettartama végén a terméket és elektronikus tartozékait (pl. töltőegység, fejhallgató, USB kábel) nem szabad a háztartási hulladékkal együtt kidobni. A szabálytalan hulladékba helyezés által okozott környezeti- és egészségkárosodás megelőzése érdekében ezeket a tárgyakat különítse el a többi hulladéktól, és felelősségteljesen gondoskodjon az újrahazsnosításukról az anyagi erőforrások fenntartható újrafelhasználásának elősegítése érdekében. A háztartási felhasználók a termék forgalmazójától vagy a helyi önkormányzati szervektől kérjenek tanácsot arra vonatkozóan, hová és hogyan vihetik el az elhasznált termékeket a környezetvédelmi szempontból biztonságos újrahazsnosítás céljából. Az üzleti felhasználók lépjenek kapcsolatba beszállítójukkal, és vizsgálják meg az adásvételi szerződés feltételeit. Ezt a terméket és tartozékait nem szabad az egyéb közületi hulladékkal együtt kezelni.

[Magyar]



Prawidłowe usuwanie produktu (zużyty sprzęt elektryczny i elektroniczny)

To oznaczenie umieszczone na produkcie, akcesoriach lub dokumentacji oznacza, że po zakończeniu eksploatacji nie należy tego produktu ani jego akcesoriów (np. ładowarki, zestawu słuchawkowego, przewodu USB) wyrzucać wraz ze zwykłymi odpadami gospodarstwa domowego. Aby uniknąć szkodliwego wpływu na środowisko naturalne i zdrowie ludzi wskutek niekontrolowanego usuwania odpadów, prosimy o oddzielenie tych przedmiotów od odpadów innego typu oraz o odpowiedzialny recykling i praktykowanie ponownego wykorzystania materiałów. W celu uzyskania informacji na temat miejsca i sposobu bezpiecznego dla środowiska recyklingu tych przedmiotów, użytkownicy w gospodarstwach domowych powinni skontaktować się z punktem sprzedaży detalicznej, w którym dokonali zakupu produktu, lub z organem władz lokalnych. Użytkownicy w firmach powinni skontaktować się ze swoim dostawcą i sprawdzić warunki umowy zakupu. Produktu ani jego akcesoriów nie należy usuwać razem z innymi odpadami komercyjnymi.

[Polski]



Σωστή Απόρριψη αυτού του Προϊόντος (Απόβλητα Ηλεκτρικού & Ηλεκτρονικού Εξοπλισμού)

(Ισχύει για την Ευρωπαϊκή Ένωση και για άλλες ευρωπαϊκές χώρες με χωριστά συστήματα συλλογής) Αυτό το σήμα που εμφανίζεται επάνω στο προϊόν, στα εξαρτήματά του ή στα χειριρίδια που το συνοδεύουν, υποδεικνύει ότι το προϊόν και τα ηλεκτρονικά του εξαρτήματα (π.χ. φορητοί, ακουστικά, καλώδιο USB) δεν θα πρέπει να ρίπνονται μαζί με τα υπόλοιπα οικιακά απορρίμματα μετά το τέλος του κύκλου ζωής τους. Προκειμένου να αποφευχθούν ενδεχόμενες βλαβερές συνέπειες στο περιβάλλον ή την υγεία εξαιτίας της ανεξέλεγκτης διάθεσης απορριμμάτων, σας παρακαλούμε να διαχωρίσετε αυτά τα προϊόντα από άλλους τύπους απορριμμάτων και να τα ανακυκλώσετε, ώστε να βοηθήσετε στην βιώσιμη επαναχρησιμοποίηση των υλικών πόρων. Οι οικιακοί χρήστες θα πρέπει να έλθουν σε επικοινωνία είτε με το κατάστημα απ' όπου αγοράσαν αυτό το προϊόν, είτε με τις κατά τόπους υπηρεσίες, προκειμένου να πληροφορηθούν τις λεπτομέρειες σχετικά με τον τόπο και τον τρόπο με τον οποίο μπορούν να δώσουν αυτά τα προϊόντα για ασφαλή προς το περιβάλλον ανακύκλωση. Οι επιχειρήσεις-χρήστες θα πρέπει να έλθουν σε επαφή με τον προμηθευτή τους και να ελέγξουν τους όρους και τις προϋποθέσεις του συμβολαίου αγοράς. Αυτό το προϊόν και τα ηλεκτρονικά του εξαρτήματα δεν θα πρέπει να αναμειγνύονται με άλλα συνηθισμένα απορρίμματα προς διάθεση.

[Ελληνικά]

Правилно третиране на изделието след края на експлоатационния му живот

(Отпадъци, представляващи електрическо и електронно оборудване)(Важи за държавите на Европейския съюз и други европейски държави със системи за разделно сметосъбиране)



Този знак, поставен върху изделието, негови принадлежности или печатни материали, означава, че продуктът и принадлежностите (например зарядно устройство, слушалки, USB кабел) не бива да се изхвърлят заедно с другите битови отпадъци, когато изтече експлоатационният му живот. Отделяйте тези устройства от другите видове отпадъци и ги предавайте за рециклиране. Спазвайки това правило не излагате на опасност здравето на други хора и предпазвате околната среда от замърсяване, предизвикано от неконтролно изхвърляне на отпадъци. Освен това, подобно отговорно поведение създава възможност за повторно (екологично съобразно) използване на материалните ресурси. Домашните потребители трябва да се свържат с търговеца на дребно, от когото са закупили изделието, или със съответната местна държавна агенция, за да получат подробни инструкции къде и кога могат да занесат тези устройства за рециклиране, безопасно за околната среда. Корпоративните потребители следва да се свържат с доставчика си и да проверят условията на договора за покупка. Това изделие и неговите електронни принадлежности не бива да се смесват с другите отпадъци на търговското предприятие.

[Български]

Správna likvidace výrobku (Elektrický a elektronický odpad)

Toto označení na výrobku, jeho příslušenství nebo dokumentaci znamená, že výrobek a jeho elektronické příslušenství (například nabíječku, náhlavní sadu, USB kabel) je po skončení životnosti zakázáno likvidovat jako běžný komunální odpad. Možným negativním dopadům na životní prostředí nebo lidské zdraví způsobeným nekontrolovanou likvidací zabráníte oddělením zmíněných produktů od ostatních typů odpadu a jejich zodpovědnou recyklací za účelem udržitelného využívání druhotných surovin. Uživatelé z řad domácností by si měli od prodejce, u něhož produkt zakoupili, nebo u příslušného městského úřadu vyžádat informace, kde a jak mohou tyto výrobky odevzdat k bezpečné ekologické recyklaci. Podnikoví uživatelé by měli kontaktovat dodavatele a zkontrolovat všechny podmínky kupní smlouvy. Tento výrobek a jeho elektronické příslušenství nesmí být likvidován spolu s ostatním průmyslovým odpadem.

[Čeština]

Správna likvidácia tohoto výrobku (Elektrotechnický a elektronický odpad)

(Platné pre Európsku úniu a ostatné európske krajiny so systémom triedeného odpadu)

Toto označenie na výrobku, príslušenstve alebo v sprievodnej brožúre hovorí, že po skončení životnosti by produkt ani jeho elektronické príslušenstvo (napr. nabíjačka, náhlavná súprava, USB kábel) nemali byť likvidované s ostatným domovým odpadom. Prípadnému poškodeniu životného prostredia alebo ľudského zdravia môžete predísť tým, že budete tieto výrobky oddeľovať od ostatného odpadu a vrátiť ich na recykláciu. Používatelia v domácnostiach by pre podrobné informácie, ako ekologicky bezpečne naložiť s týmito výrobkami, mali kontaktovať buď predajcu, ktorý im ich predal, alebo príslušný úrad v mieste ich bydliska. Priemyselní používatelia by mali kontaktovať svojho dodávateľa a overiť si podmienky kúpnej zmluvy. Tento výrobok a ani jeho elektronické príslušenstvo by nemali byť likvidované spolu s ostatným priemyselným odpadom.

[Slovensky]

Cum se elimină corect acest produs (Deșeurii de echipamente electrice și electronice)

(Aplicabil în țările Uniunii Europene și în alte țări cu sisteme de colectare selectivă)

Acest simbol de pe produs, accesorii și documentație indică faptul că produsul și accesoriiile sale electronice (încărcător, căști, cablu USB) nu trebuie eliminate împreună cu alte deșeurii menajere la finalul duratei lor de utilizare. Dat fiind că eliminarea necontrolată a deșeurilor poate dăuna mediului înconjurător sau sănătății umane, vă rugăm să separați aceste articole de alte tipuri de deșeurii și să le reciclați în mod responsabil, promovând astfel reutilizarea durabilă a resurselor materiale. Utilizatorii casnici trebuie să-l contacteze pe distribuitorul care le-a vândut produsul sau să se intereseze la autoritățile locale unde și cum pot să ducă aceste articole pentru a fi reciclate în mod ecologic. Utilizatorii comerciali trebuie să-și contacteze furnizorul și să consulte termenii și condițiile din contractul de achiziție. Acest produs și accesoriiile sale electronice nu trebuie eliminate împreună cu alte deșeurii comerciale.

[Română]

Izstrādājuma pareiza likvidēšana (Attiecās uz nolietotām elektriskām un elektroniskām ierīcēm)

(Spēkā Eiropas Savienībā un pārējās Eiropas valstīs, kas izmanto atkritumu dalītu savākšanu)

Šis uz izstrādājuma un tā piederumiem vai pievienotajā dokumentācijā izvietotais marķējums norāda, ka izstrādājumu un tā elektroniskos piederumus (piem., uzlādes ierīci, austiņas, USB kabeli) pēc ekspluatācijas laika beigām nedrīkst likvidēt kopā ar citiem sadzīves atkritumiem. Lai nepieļautu atkritumu nekontrolētas likvidēšanas radītu varbūtēju kaitējumu videi un cilvēku veselībai, lūdzam minētās ierīces nošķirt no citiem atkritumiem un disciplinēti nodot pienācīgai pārstrādei, tā sekmējot materiālo resursu atkārtotu izmantošanu. Lai uzzinātu, kur un kā minētās ierīces iespējams nodot ekoloģiski drošai pārstrādei, mājāsaimniecībām jāsasazinās ar izstrādājuma pārdevēju vai savu pašvaldību. Iestādēm un uzņēmumiem jāsasazinās ar izstrādājuma piegādātāju un jāiepazīstas ar pirkuma līguma nosacījumiem. Izstrādājumu un tā elektroniskos piederumus nedrīkst nodot likvidēšanai kopā ar citiem iestāžu un uzņēmumu atkritumiem.

[Latviešu]

Tinkamas šio gaminio išmetimas (elektros ir elektroninės įrangos atliekos)

Šis ženklas, pateiktas ant gaminio, jo priedų ar dokumentacijoje, nurodo, kad gaminio ir jo elektroninių priedų (pvz., įkroviklio, ausinių, USB kabelio) negalima išmesti kartu su kitomis buitinėmis atliekomis gaminio naudojimo laikui pasibaigus. Kad būtų išvengta galimos nekontroliuojamo atliekų išmetimo žalos aplinkai arba žmonių sveikatai ir skatinamas aplinkai tausojantis antrinių žaliavų panaudojimas, atskirkite šiuos elementus nuo kitų rūšių atliekų ir atiduokite perdirbti. Informacijos kur ir kaip pristatyti šiuos elementus saugiai perdirbti, privatus vartotojai turėtų kreiptis į parduotuvę, kurioje šį gaminį pirkė, arba į vietos valdžios institucijas. Verslo vartotojai turėtų kreiptis į savo tiekėją ir peržiūrėti pirkimo sutarties sąlygas. Tvarkant atliekas, šio gaminio ir jo elektroninių priedų negalima maišyti su kitomis pramoninėmis atliekomis.

[Lietuvių]



Õige viis toote kasutusest kõrvaldamiseks (elektriliste ja elektrooniliste seadmete jäätmed)

Selline tähistus tootel või selle tarvikutel või dokumentidel näitab, et toodet ega selle elektroonilisi tarvikuid (nt laadija, peakomplekt, USB-kaabel) ei tohi kasutusaja lõppemisel kõrvaldada koos muude olmejäätmetega. Selleks et vältida jäätmete kontrollimatu kõrvaldamisega seotud võimaliku kahju tekitamist keskkonnale või inimeste tervisele ning edendada materiaalsete vahendite säästvat taaskasutust, eraldage need esemed muudest jäätmetest ja suunake need vastutustundlikult taasinglusse. Kodukasutajad saavad teavet nende esemete keskkonnohutu ringlussevõtu kohta kas toote müüjalt või keskkonnaametist. Firmed peaksid võtma ühendust tarnijaga ning kontrollima ostulepingu tingimusi ja sätteid. Toodet ega selle elektroonilisi tarvikuid ei tohi panna muude hävitamiseks mõeldud kaubandusjäätmete hulka.

[Eesti]



Correct disposal of batteries in this product

(Applicable in the European Union and other European countries with separate battery return systems.)

This marking on the battery, manual or packaging indicates that the batteries in this product should not be disposed of with other household waste at the end of their working life. Where marked, the chemical symbols Hg, Cd or Pb indicate that the battery contains mercury, cadmium or lead above the reference levels in EC Directive 2006/66. If batteries are not properly disposed of, these substances can cause harm to human health or the environment. To protect natural resources and to promote material reuse, please separate batteries from other types of waste and recycle them through your local, free battery return system.

[English]



Elimination des batteries de ce produit

(Applicable aux pays de l'Union européenne et aux autres pays européens dans lesquels des systèmes de collecte sélective sont mis en place.)

Le symbole sur la batterie, le manuel ou l'emballage indique que les batteries de ce produit ne doivent pas être éliminées en fin de vie avec les autres déchets ménagers. L'indication éventuelle des symboles chimiques Hg, Cd ou Pb signifie que la batterie contient des quantités de mercure, de cadmium ou de plomb supérieures aux niveaux de référence stipulés dans la directive CE 2006/66. Si les batteries ne sont pas correctement éliminées, ces substances peuvent porter préjudice à la santé humaine ou à l'environnement. Afin de protéger les ressources naturelles et d'encourager la réutilisation du matériel, veillez à séparer les batteries des autres types de déchets et à les recycler via votre système local de collecte gratuite des batteries.

[Français]



Korrekte Entsorgung der Batterien dieses Produkts

(In den Ländern der Europäischen Union und anderen europäischen Ländern mit einem separaten Altbatterie-Rücknahmesystem)

Die Kennzeichnung auf der Batterie bzw. auf der dazugehörigen Dokumentation oder Verpackung gibt an, dass die Batterie zu diesem Produkt nach seiner Lebensdauer nicht zusammen mit dem normalen Haushaltsmüll entsorgt werden darf. Wenn die Batterie mit den chemischen Symbolen Hg, Cd oder Pb gekennzeichnet ist, liegt der Quecksilber-, Cadmium- oder Blei-Gehalt der Batterie über den in der EG-Richtlinie 2006/66 festgelegten Referenzwerten. Wenn Batterien nicht ordnungsgemäß entsorgt werden, können sie der menschlichen Gesundheit bzw. der Umwelt schaden. Bitte helfen Sie, die natürlichen Ressourcen zu schützen und die nachhaltige Wiederverwertung von stofflichen Ressourcen zu fördern, indem Sie die Batterien von anderen Abfällen getrennt über Ihr örtliches kostenloses Altbatterie-Rücknahmesystem entsorgen.

[Deutsch]



Correcte behandeling van een gebruikte accu uit dit product

(Van toepassing op de Europese Unie en andere Europese landen met afzonderlijke inzamelingsystemen voor accu's en batterijen.)

Dit merkteken op de accu, handleiding of verpakking geeft aan dat de accu in dit product aan het einde van de levensduur niet samen met ander huishoudelijk afval mag worden weggegooid. De chemische symbolen Hg, Cd of Pb geven aan dat het kwik-, cadmium- of loodgehalte in de accu hoger is dan de referentieniveaus in de Richtlijn 2006/66/EC. Indien de gebruikte accu niet op de juiste wijze wordt behandeld, kunnen deze stoffen schadelijk zijn voor de gezondheid van mensen of het milieu. Ter bescherming van de natuurlijke hulpbronnen en ter bevordering van het hergebruik van materialen, verzoeken wij u afgedankte accu's en batterijen te scheiden van andere soorten afval en voor recycling aan te bieden bij het gratis inzamelingsstelsel voor accu's en batterijen in uw omgeving.

[Nederlands]



Corretto smaltimento delle batterie del prodotto

(Applicabile nei paesi dell'Unione Europea e in altri paesi europei con sistemi di conferimento differenziato delle batterie.)

Il marchio riportato sulla batteria o sulla sua documentazione o confezione indica che le batterie di questo prodotto non devono essere smaltite con altri rifiuti domestici al termine del ciclo di vita. Dove raffigurati, i simboli chimici Hg, Cd o Pb indicano che la batteria contiene mercurio, cadmio o piombo in quantità superiori ai livelli di riferimento della direttiva UE 2006/66. Se le batterie non vengono smaltite correttamente, queste sostanze possono causare danni alla salute umana o all'ambiente. Per proteggere le risorse naturali e favorire il riutilizzo dei materiali, separare le batterie dagli altri tipi di rifiuti e riciclarle utilizzando il sistema di conferimento gratuito previsto nella propria area di residenza.

[Italiano]



Eliminación correcta de las baterías de este producto

(Aplicable en la Unión Europea y en otros países europeos con sistemas de recogida selectiva de baterías.)

La presencia de esta marca en las baterías, el manual o el paquete del producto indica que cuando haya finalizado la vida útil de las baterías no deberán eliminarse junto con otros residuos domésticos. Los símbolos químicos Hg, Cd o Pb, si aparecen, indican que la batería contiene mercurio, cadmio o plomo en niveles superiores a los valores de referencia admitidos por la Directiva 2006/66 de la Unión Europea. Si las baterías no se desechan convenientemente, estas sustancias podrían provocar lesiones personales o dañar el medioambiente. Para proteger los recursos naturales y promover el reciclaje, separe las baterías de los demás residuos y reciclelas mediante el sistema de recogida gratuito de su localidad.

[Español]



Eliminação correcta das baterias existentes neste produto

(Aplicável na União Europeia e noutros países europeus com sistemas de recolha de baterias separados.)

Esta marca, apresentada na bateria, manual ou embalagem, indica que as baterias existentes neste produto não devem ser eliminadas juntamente com os resíduos domésticos indiferenciados no final do seu período de vida útil. Onde existentes, os símbolos químicos Hg, Cd ou Pb indicam que a bateria contém mercúrio, cádmio ou chumbo acima dos níveis de referência indicados na Directiva CE 2006/66. Se as baterias não forem correctamente eliminadas, estas substâncias poderão ser prejudiciais para a saúde humana ou para o meio ambiente. Para proteger os recursos naturais e promover a reutilização dos materiais, separe as baterias dos outros tipos de resíduos e recicle-as através do sistema gratuito de recolha local de baterias.

[Português]



Ustrezno odstranjevanje baterij v tem izdelku

(Uporabno v EU in ostalih evropskih državah s sistemi ločenega odstranjevanja baterij)

Ta oznaka na bateriji, v navodilih ali na embalaži pomeni, da baterij ob izteku njihove življenjske dobe v tem izdelku ne smete odstraniti skupaj z ostalimi gospodinjstskimi odpadki. Oznake za kemijske elemente Hg, Cd ali Pb pomenijo, da baterija vsebuje živo srebro, kadmij ali svinec v količinah, ki presegajo referenčne nivoje v direktivi EC 2006/66. Če te baterije niso ustrezno odstranjene, te snovi lahko škodujejo zdravju ljudi oziroma okolju. Za zaščito naravnih virov in za vzpodbujanje ponovne uporabe materialov prosimo, ločite te baterije od ostalih odpadkov in jih oddajte na predvidenih lokalnih zbirnih reciklažnih mestih.

[Slovenščina]



Korrekt avfallshantering av batterierna i denna produkt

(Gäller EU och andra europeiska länder med särskild batteriåtervinning.) Denna markering på batteriet, i manualen eller på förpackningen

anger att batterierna i denna produkt inte bör slängas tillsammans med annat hushållsavfall. De kemiska symbolerna Hg, Cd eller Pb visar i förekommande fall att batterierna innehåller kvicksilver, kadmium eller bly i mängder överstigande de gränsvärden som anges i EU-direktivet 2006/66. Om batterierna inte slängs på ett ansvarsfullt sätt kan dessa substanser utgöra en fara för hälsa eller miljö. Hjälp till att skydda naturresurser och bidra till materialåtervinning genom att sortera batterierna separat från annat avfall och lämna in dem på en återvinningsstation.

[Svenska]

KKorrekt bortskaftelse af batterierne i dette produkt

(Gælder i EU og andre europæiske lande med særlige retursystemer for batterier.)



Mærket på dette batteri, dokumentationen eller emballagen betyder, at batterierne i dette produkt efter endt levetid ikke må bortskaftes sammen med andet husholdningsaffald. Mærkning med de kemiske symboler Hg, Cd eller Pb betyder, at batteriet indeholder kviksølv, cadmium eller bly over grænseværdierne i EU-direktiv 2006/66. Hvis batterierne ikke bortskaftes korrekt, kan disse stoffer være skadelige for menneskers helbred eller miljøet. For at beskytte naturressourcer og fremme genbrug, skal batterier holdes adskilt fra andre typer affald og genanvendes via dit lokale, gratis batteriretursystem.

[Dansk]

Korrekt avhending av batterier i dette produkt

(Kommer til anvendelse i Den europeiske union og i andre europeiske land med separate systemer for retur av batterier.)



Denne merkingen på batteriet, håndboken eller emballasjen angir at batteriene i dette produktet ikke skal kastes sammen med annet husholdningsavfall ved slutten av sin levetid. Der det er merket, angir de kjemiske symbolene Hg, Cd eller Pb at batteriet inneholder kviksølv, kadmiom eller bly over referansenivåene i EF-direktiv 2006/66. Hvis batteriene ikke avhendes på riktig måte, kan disse stoffene skade menneskers helse eller miljøet. For å beskytte naturressurser og for å fremme gjenbruk av materialer, ber vi deg adskille batterier fra andre typer avfall og resirkulere dem ved å levere dem på din lokale, gratis mottaksstasjon.

[Norsk]

Tuotteen paristojen oikea hävittäminen

(Koskee Euroopan Unionia ja muita Euroopan maita, joissa on erillinen paristojen palautusjärjestelmä.)



Pariston, käyttöoppaan tai pakkauksen tämä merkintä tarkoittaa, että tämän tuotteen sisältämiä paristoja ei saa hävittää muun kotitalousjätteen seassa, kun niiden käyttöikä on päättynyt. Kemiaallinen symboli Hg, Cd tai Pb ilmaisee, että paristo sisältää elohopeaa, kadmiumia tai lyijyä ylin EU: n direktiivien 2006/66 viiterajojen. Jos paristoja ei hävitetä oikein, nämä aineet voivat vahingoittaa ihmisten terveyttä tai ympäristöä. Suojaa luonnonvaroja ja edistä materiaalien uusiokäyttöä - erottele paristot muusta jätteestä ja toimita ne kierrätettäväksi paikalliseen maksuttomaan paristojen palautusjärjestelmään.

[Suomi]

A termékhez tartozó akkumulátorok megfelelő ártalmatlanítása

(Az Európai Unió területén és más, önálló akkumulátorleadó rendszerrel rendelkező európai országok területén alkalmazandó.)



Az akkumulátoron, a kézikönyvön vagy a csomagoláson szereplő jelzés arra utal, hogy hasznos élettartama végén a terméket nem szabad egyéb háztartási hulladékkal együtt kidobni. Ahol szerepel a jelzés, a Hg, Cd vagy Pb kémiai elemjelölések arra utalnak, hogy az akkumulátor az EK 2006/66. számú irányelvben rögzített referenciaszintet meghaladó mennyiségű higanyt, kadmiumot vagy ólmot tartalmaz. Az akkumulátorok nem megfelelő kezelése esetén ezek az anyagok veszélyt jelenthetnek az egészségre vagy a környezetre. A természeti erőforrások megóvása és az anyagok újrafelhasználásának ösztönzése érdekében kérjük, különítse el az akkumulátorokat a többi hulladéktól és vigye vissza a helyi, ingyenes akkumulátorleadó helyre.

[Magyar]

Sposób poprawnego usuwania baterii, w które wyposażony jest niniejszy produkt

(Dotyczy obszaru Unii Europejskiej oraz innych krajów europejskich posiadających oddzielne systemy zwrotu zużytych baterii.)



Niniejsze oznaczenie na baterii, instrukcji obsługi lub opakowaniu oznacza, że po upływie okresu użytkowania baterie, w które wyposażony był dany produkt, nie mogą zostać usunięte wraz z innymi odpadami pochodzącymi z gospodarstw domowych. Przy zastosowaniu takiego oznaczenia symbole chemiczne (Hg, Cd lub Pb) wskazują, że dana bateria zawiera rtęć, kadm lub ołów w ilości przewyższającej poziomy odniesienia opisane w dyrektywie WE 2006/66. Jeśli baterie nie zostaną poprawnie zutylizowane, substancje te mogą powodować zagrożenie dla zdrowia ludzkiego lub środowiska naturalnego. Aby chronić zasoby naturalne i promować ponowne wykorzystanie materiałów, należy oddzielać baterie od innego typu odpadów i poddawać je utylizacji poprzez lokalny, bezpłatny system zwrotu baterii.

[Polski]

Σωστή απόρριψη των μπαταριών αυτού του προϊόντος

(Ισχύει στην Ευρωπαϊκή Ένωση και άλλες ευρωπαϊκές χώρες με συστήματα ξεχωριστής ανακύκλωσης μπαταριών.)



Αυτή η επισήμανση πάνω στη μπαταρία, το εγχειρίδιο ή τη συσκευασία υποδεικνύει ότι οι μπαταρίες αυτού του προϊόντος δεν πρέπει να απορριπτόνται μαζί με άλλα οικιακά απορρίμματα στο τέλος του κύκλου ζωής τους. Όπου υπάρχουν, τα χημικά σύμβολα Hg, Cd ή Pb υποδεικνύουν ότι η μπαταρία περιέχει υδράργυρο, κάδμιο ή μόλυβδο πάνω από τα επίπεδα αναφοράς της Ευρωπαϊκής Οδηγίας 2006/66. Αν οι μπαταρίες δεν απορριφθούν σωστά, αυτές οι ουσίες ενδέχεται να προκαλέσουν βλαβερές συνέπειες στην ανθρώπινη υγεία ή το περιβάλλον. Παρακαλούμε διαχωρίζετε τις μπαταρίες από άλλους τύπους απορριμμάτων και ανακυκλώνετε τις μέσω του τοπικού σας, δωρεάν συστήματος ανακύκλωσης μπαταριών, για την προστασία των φυσικών πόρων και την προώθηση της αναπαραχρησιμοποίησης υλικών.

[Ελληνικά]

Правилно изхвърляне на батериите в този продукт

(Приложимо в Европейския съюз и други европейски държави със самостоятелни системи за връщане на батерии.)



Това обозначение върху батерията, ръководството или опаковката, показва, че батериите в този продукт не бива да се изхвърлят с другите битови отпадъци в края на техния полезен живот. Където са маркирани, химическите символи Hg, Cd или Pb показват, че батерията съдържа живак, кадмий или олово над контролните нива в Директива 2006/66 на ЕО. Ако батериите не се изхвърлят правилно, тези вещества могат да предизвикат увреждане на човешкото здраве или на околната среда. За да предпазите природните ресурси и за да съдействате за многократната употреба на материалните ресурси, моля отделяйте батериите от другите видове отпадъчни продукти и ги рециклирайте посредством Вашата локална система за безплатно връщане на батерии.

[Български]

Správná likvidace baterií v tomto výrobku

(Platí v Evropské unii a dalších evropských zemích s vlastními systémy zpětného odběru baterií.)



Tato značka na baterii, návodu nebo obalu znamená, že baterie v tomto výrobku nesmí být na konci své životnosti likvidovány společně s jiným domovním odpadem. Případně vyznačené symboly chemikálií Hg, Cd nebo Pb upozorňují na to, že baterie obsahuje rtuť, kadmium nebo olovo v množství překračujícím referenční úroveň stanovené směrnicí ES 2006/66. Pokud baterie nejsou správně zlikvidovány, mohou tyto látky poškodit zdraví osob nebo životní prostředí. Pro ochranu přírodních zdrojů a pro podporu opakovaného využívání materiálů oddělte, prosím, baterie od ostatních typů odpadu a nechte je recyklovat prostřednictvím místního bezplatného systému zpětného odběru baterií.

[Čeština]

Správná likvidácia baterií v tomto výrobku

(Aplikovateľné v krajinách Európskej únie a v ostatných európskych krajinách, v ktorých existujú systémy separovaného zberu baterií.)



Toto označenie na batérii, príručke alebo balení hovorí, že batérie v tomto výrobku by sa po skončení ich životnosti nemali likvidovať spolu s ostatným domovým odpadom. V prípade takéhoto označenia chemické symboly Hg, Cd alebo Pb znamenajú, že batéria obsahuje ortuť, kadmium alebo olovo v množstve presahujúcom referenčné hodnoty smernice 2006/66/ES. Pri nevhodnej likvidácii batérií môžu tieto látky poškodiť zdravie alebo životné prostredie. Za účelom ochrany prírodných zdrojov a podpory opätovného použitia materiálu batérie likvidujte oddelene od iných typov odpadov a recyklujte ich prostredníctvom miestneho systému bezplatného zberu batérií.

[Slovensky]

Dispoziții privind eliminarea corectă a bateriilor acestui produs

(aplicabile în Uniunea Europeană și în alte țări europene cu sisteme separate de colectare a bateriilor)



Acest marcaj de pe baterie, de pe manualul de utilizare sau de pe ambalaj indică faptul că bateriile acestui produs nu trebuie eliminate împreună cu alte deșeurii menajere la sfârșitul ciclului lor de viață. Dacă sunt marcate, simbolurile chimice Hg, Cd sau Pb indică faptul că bateria conține mercur, cadmiu sau plumb peste nivelurile de referință prevăzute în Directiva CE 2006/66. În cazul în care bateriile nu sunt eliminate corespunzător, aceste substanțe pot fi dăunătoare pentru sănătatea omului sau pentru mediu. În vederea protejării resurselor naturale și a promovării refolosirii materialelor, vă rugăm să separați bateriile de celelalte tipuri de deșeurii și să le reciclați prin intermediul sistemului gratuit de returnare a bateriilor la nivel local.

[Română]

Ši izstrādājuma bateriju pareiza utilizācija

(Piemērojama Eiropas Savienībā un citās Eiropas valstīs ar atsevišķām bateriju nodošanas sistēmām.)



Šis marķējums uz baterijas, rokasgrāmatā vai uz iepakojuma norāda, ka šī izstrādājuma bateriju pēc tās kalpošanas laika beigām nedrīkst izmest ar citiem sadzīves atkritumiem. Ja uz baterijas ir atzīmēti ķīmiskie simboli, piem., Hg, Cd vai Pb, tie norāda, ka baterija satur dzīvsudrabu, kadmiju vai svini, kura saturs ir lielāks par EK Direktīvā 2006/66 minētajiem līmeņiem. Ja baterijas tiek nepareizi likvidētas, šīs vielas var radīt kaitējumu cilvēku veselībai vai videi. Lai aizsargātu dabas resursus un veicinātu materiālu atbilstošu izmantošanu, šķirojiet baterijas atsevišķi no citiem atkritumu veidiem un nododiet tās atbilstoši pārstrādei, izmantojot bateriju vietējo bezmaksas nodošanas sistēmu.

[Lietuvių]

Tinkamas šio produkto akumuliatorių tvarkymas

(Taikoma Europos Sąjungoje ir kitose Europos šalyse, kuriose galioja atskiros akumuliatorių grąžinimo sistemos.)



Šis ženklas yra pateikiamas ant akumuliatoriaus, jo dokumentacijoje ar ant pakuotės nurodo, kad šio produkto akumuliatorių, pasibaigus jų tarnavimo laikui, negalima išmesti kartu su kitomis buitinėmis atliekomis. Cheminiai simboliai Hg, Cd arba Pb rodo, kad akumuliatoriuje yra gyvsidabrio, kadmio ar švino, kurio kiekis viršija normą, nurodytą ES direktyvoje 2006/66. Jei akumuliatoriai nebus tinkamai išmesti, šios medžiagos gali sukelti žalos žmonių sveikatai ar aplinkai. Tam, kad būtų apsaugoti gamtos išteklių ir skatinamas antrinių žaliavų panaudojimas, pašome atskirti akumuliatorių nuo kitų rūšių atliekų ir atiduoti perdirbti vietinėje akumuliatorių grąžinimo sistemoje.

[Lietuvių]

Õige viis toote akude kasutuselst kõrvaldamiseks

(Rakendatav Euroopa Liidus ja teistes Euroopa riikides, kus on kasutusel spetsiaalsed akude kogumissüsteemid.)



Selline tähistus akul, dokumentidel või pakendil näitab, et toote akusid ei tohi kasutusaja lõppemisel kõrvaldada koos muude olmejäätmetega. Keemilised elemendid Hg, Cd, või Pb näitavad, et aku elavhõbeda, kaadmiumi või plii sisaldus on EÜ direktiivi 2006/66 sihttasemest suurem. Kui akusid ei kõrvaldata õigel viisil, võib nende sisu põhjustada tervise-või keskkonnakahjustusi. Selleks, et kaitsta loodusvarasid ja edendada materjalide taaskasutamist, eraldage akud muudest jäätmetest ja suunake need taaskasutusse kohaliku, tasuta teenusena pakutava akude tagastussüsteemi abil.

[Eesti]