

ONKYO®

DVD Receiver

DR-645

Instruction Manual

Thank you for purchasing an Onkyo DVD Receiver. Please read this manual thoroughly before making connections and plugging in the unit. Following the instructions in this manual will enable you to obtain optimum performance and listening enjoyment from your new DVD Receiver. Please retain this manual for future reference.

Contents

Introduction2

Connections.....8

Basic Operation 18

Settings25

Listening to the FM Radio29

Troubleshooting31



WARNING:

TO REDUCE THE RISK OF FIRE OR ELECTRIC SHOCK, DO NOT EXPOSE THIS APPARATUS TO RAIN OR MOISTURE.

CAUTION:

TO REDUCE THE RISK OF ELECTRIC SHOCK, DO NOT REMOVE COVER (OR BACK). NO USER-SERVICEABLE PARTS INSIDE. REFER SERVICING TO QUALIFIED SERVICE PERSONNEL.



WARNING
RISK OF ELECTRIC SHOCK
DO NOT OPEN

AVIS
RISQUE DE CHOC ELECTRIQUE
NE PAS OUVRIR



The lightning flash with arrowhead symbol, within an equilateral triangle, is intended to alert the user to the presence of uninsulated "dangerous voltage" within the product's enclosure that may be of sufficient magnitude to constitute a risk of electric shock to persons.



The exclamation point within an equilateral triangle is intended to alert the user to the presence of important operating and maintenance (servicing) instructions in the literature accompanying the appliance.

Important Safety Instructions

1. Read these instructions.
2. Keep these instructions.
3. Heed all warnings.
4. Follow all instructions.
5. Do not use this apparatus near water.
6. Clean only with dry cloth.
7. Do not block any ventilation openings. Install in accordance with the manufacturer's instructions.
8. Do not install near any heat sources such as radiators, heat registers, stoves, or other apparatus (including amplifiers) that produce heat.
9. Do not defeat the safety purpose of the polarized or grounding-type plug. A polarized plug has two blades with one wider than the other. A grounding type plug has two blades and a third grounding prong. The wide blade or the third prong are provided for your safety. If the provided plug does not fit into your outlet, consult an electrician for replacement of the obsolete outlet.
10. Protect the power cord from being walked on or pinched particularly at plugs, convenience receptacles, and the point where they exit from the apparatus.
11. Only use attachments/accessories specified by the manufacturer.
12. Use only with the cart, stand, tripod, bracket, or table specified by the manufacturer, or sold with the apparatus. When a cart is used, use caution when moving the cart/apparatus combination to avoid injury from tip-over.

PORTABLE CART WARNING
S3125A
13. Unplug this apparatus during lightning storms or when unused for long periods of time.
14. Refer all servicing to qualified service personnel. Servicing is required when the apparatus has been damaged in any way, such as power-supply cord or plug is damaged, liquid has been spilled or objects have fallen into the apparatus, the apparatus has been exposed to rain or moisture, does not operate normally, or has been dropped.
15. Damage Requiring Service
Unplug the apparatus from the wall outlet and refer servicing to qualified service personnel under the following conditions:
 - A. When the power-supply cord or plug is damaged,
 - B. If liquid has been spilled, or objects have fallen into the apparatus,
 - C. If the apparatus has been exposed to rain or water,
 - D. If the apparatus does not operate normally by following the operating instructions. Adjust only those controls that are covered by the operating instructions as an improper adjustment of other controls may result in damage and will often require extensive work by a qualified technician to restore the apparatus to its normal operation,
 - E. If the apparatus has been dropped or damaged in any way, and
 - F. When the apparatus exhibits a distinct change in performance this indicates a need for service.
16. Object and Liquid Entry
Never push objects of any kind into the apparatus through openings as they may touch dangerous voltage points or short-out parts that could result in a fire or electric shock.
The apparatus shall not be exposed to dripping or splashing and no objects filled with liquids, such as vases shall be placed on the apparatus.
Don't put candles or other burning objects on top of this unit.
17. Batteries
Always consider the environmental issues and follow local regulations when disposing of batteries.
18. If you install the apparatus in a built-in installation, such as a bookcase or rack, ensure that there is adequate ventilation.
Leave 20 cm (8") of free space at the top and sides and 10 cm (4") at the rear. The rear edge of the shelf or board above the apparatus shall be set 10 cm (4") away from the rear panel or wall, creating a flue-like gap for warm air to escape.

Precautions

1. Recording Copyright—Unless it's for personal use only, recording copyrighted material is illegal without the permission of the copyright holder.

2. AC Fuse—The AC fuse inside the unit is not user-serviceable. If you cannot turn on the unit, contact your Onkyo dealer.

3. Care—Occasionally you should dust the unit all over with a soft cloth. For stubborn stains, use a soft cloth dampened with a weak solution of mild detergent and water. Dry the unit immediately afterwards with a clean cloth. Don't use abrasive cloths, thinners, alcohol, or other chemical solvents, because they may damage the finish or remove the panel lettering.

4. Power

WARNING

BEFORE PLUGGING IN THE UNIT FOR THE FIRST TIME, READ THE FOLLOWING SECTION CAREFULLY.

AC outlet voltages vary from country to country. Make sure that the voltage in your area meets the voltage requirements printed on the unit's rear panel (e.g., AC 200-240 V, 50/60 Hz or AC 120 V, 60 Hz).

The power cord plug is used to disconnect this unit from the AC power source. Make sure that the plug is readily operable (easily accessible) at all times.

Pressing **ON/STANDBY** to select Standby mode does not fully shutdown the unit. If you do not intend to use the unit for an extended period, remove the power cord from the AC outlet.

5. Preventing Hearing Loss

Caution

Excessive sound pressure from earphones and headphones can cause hearing loss.

6. Batteries and Heat Exposure

Warning

Batteries (battery pack or batteries installed) shall not be exposed to excessive heat as sunshine, fire or the like.

7. Never Touch this Unit with Wet Hands—Never handle this unit or its power cord while your hands are wet or damp. If water or any other liquid gets inside this unit, have it checked by your Onkyo dealer.

8. Handling Notes

- If you need to transport this unit, use the original packaging to pack it how it was when you originally bought it.
- Do not leave rubber or plastic items on this unit for a long time, because they may leave marks on the case.
- This unit's top and rear panels may get warm after prolonged use. This is normal.
- If you do not use this unit for a long time, it may not work properly the next time you turn it on, so be sure to use it occasionally.
- When you've finished using this unit, remove all discs and turn off the power.

9. Installing this Unit

- Install this unit in a well-ventilated location.
- Ensure that there's adequate ventilation all around this unit, especially if it's installed in an audio rack. If the ventilation is inadequate, the unit may overheat, leading to malfunction.
- Do not expose this unit to direct sunlight or heat sources, because its internal temperature may rise, shortening the life of the optical pickup.
- Avoid damp and dusty places, and places subject to vibrations from loudspeakers. Never put the unit on top of, or directly above a loudspeaker.
- Install this unit horizontally. Never use it on its side or on a sloping surface, because it may cause a malfunction.
- If you install this unit near a TV, radio, or VCR, the picture and sound quality may be affected. If this occurs, move this unit away from the TV, radio, or VCR.

10. To Obtain a Clear Picture—This unit is a hightech, precision device. If the lens on the optical pickup, or the disc drive mechanism becomes dirty or worn, the picture quality may be affected. To maintain the best picture quality, we recommend regular inspection and maintenance (cleaning or worn part replacement) every 1,000 hours of use depending on the operating environment. Contact your Onkyo dealer for details.

11. Moisture Condensation



Moisture condensation may damage this unit.

Read the following carefully:

Moisture may condense on the lens of the optical pickup, one of the most important parts inside this unit.

- Moisture condensation can occur in the following situations:
 - The unit is moved from a cold place to a warm place.
 - A heater is turned on, or cold air from an air conditioner is hitting the unit.
 - In the summer, when this unit is moved from an air conditioned room to a hot and humid place.
 - The unit is used in a humid place.
- Do not use this unit when there's the possibility of moisture condensation occurring. Doing so may damage your discs and certain parts inside this unit.

If condensation does occur, unplug the power cord and leave the unit for two to three hours in the room temperature.

12. Region Numbers—The DVD standard uses region numbers to control how discs can be played around the world, the world being divided into six regions. This unit will only play DVD discs that match its region number, which can be found on its rear panel (e.g., , ).

13. About this Manual—This manual explains how to use all of this unit's functions. Although the DVD standard offers many special features, not all discs use them all, so depending on the disc being played, this unit may not respond to certain functions. See the disc's sleeve notes for supported features.

This unit contains a semiconductor laser system and is classified as a "CLASS 1 LASER PRODUCT". So, to use this model properly, read this Instruction Manual carefully. In case of any trouble, please contact the store where you purchased the unit.

To prevent being exposed to the laser beam, do not try to open the enclosure.

CAUTION:

CLASS 1M VISIBLE AND INVISIBLE LASER RADIATION WHEN OPEN. DO NOT VIEW DIRECTLY WITH OPTICAL INSTRUMENTS. THIS PRODUCT UTILIZES A LASER. USE OF CONTROLS OR ADJUSTMENTS OR PERFORMANCE OF PROCEDURES OTHER THAN THOSE SPECIFIED HEREIN MAY RESULT IN HAZARDOUS RADIATION EXPOSURE.

The label on the right is applied on the rear panel.



1. This unit is a CLASS 1 LASER PRODUCT and employs a laser inside the cabinet.
2. To prevent the laser from being exposed, do not remove the cover. Refer servicing to qualified personnel.

For U.S. models

FCC Information for User

CAUTION:

The user changes or modifications not expressly approved by the party responsible for compliance could void the user's authority to operate the equipment.

NOTE:

This equipment has been tested and found to comply with the limits for a Class B digital device, pursuant to Part 15 of the FCC Rules. These limits are designed to provide reasonable protection against harmful interference in a residential installation.

This equipment generates, uses and can radiate radio frequency energy and, if not installed and used in accordance with the instructions, may cause harmful interference to radio communications. However, there is no guarantee that interference will not occur in a particular installation. If this equipment does cause harmful interference to radio or television reception, which can be determined by turning the equipment off and on, the user is encouraged to try to correct the interference by one or more of the following measures:

- Reorient or relocate the receiving antenna.
- Increase the separation between the equipment and receiver.
- Connect the equipment into an outlet on a circuit different from that to which the receiver is connected.
- Consult the dealer or an experienced radio/TV technician for help.

For Canadian Models

NOTE: THIS CLASS B DIGITAL APPARATUS COMPLIES WITH CANADIAN ICES-003.

For models having a power cord with a polarized plug:

CAUTION: TO PREVENT ELECTRIC SHOCK, MATCH WIDE BLADE OF PLUG TO WIDE SLOT, FULLY INSERT.

Modèle pour les Canadien

REMARQUE: CET APPAREIL NUMÉRIQUE DE LA CLASSE B EST CONFORME À LA NORME NMB-003 DU CANADA.

Sur les modèles dont la fiche est polarisée:

ATTENTION: POUR ÉVITER LES CHOCS ÉLECTRIQUES, INTRODUIRE LA LAME LA PLUS LARGE DE LA FICHE DANS LA BORNE CORRESPONDANTE DE LA PRISE ET POUSSER JUSQU'AU FOND.

For British models

Replacement and mounting of an AC plug on the power supply cord of this unit should be performed only by qualified service personnel.

IMPORTANT

The wires in the mains lead are coloured in accordance with the following code:

Blue: Neutral

Brown: Live

As the colours of the wires in the mains lead of this apparatus may not correspond with the coloured markings identifying the terminals in your plug, proceed as follows: The wire which is coloured blue must be connected to the terminal which is marked with the letter N or coloured black.

The wire which is coloured brown must be connected to the terminal which is marked with the letter L or coloured red.

IMPORTANT

The plug is fitted with an appropriate fuse. If the fuse needs to be replaced, the replacement fuse must approved by ASTA or BSI to BS1362 and have the same ampere rating as that indicated on the plug. Check for the ASTA mark or the BSI mark on the body of the fuse.

If the power cord's plug is not suitable for your socket outlets, cut it off and fit a suitable plug. Fit a suitable fuse in the plug.

For European Models

Declaration of Conformity

<p>We, ONKYO EUROPE ELECTRONICS GmbH LIEGNITZERSTRASSE 6, 82194 GROEBENZELL, GERMANY</p> <p>declare in own responsibility, that the ONKYO product described in this instruction manual is in compliance with the corresponding technical standards such as EN60065, EN55013, EN55020 and EN61000-3-2, -3-3.</p> <p style="text-align: right;">GROEBENZELL, GERMANY</p>	  K. MIYAGI
--	---

ONKYO EUROPE ELECTRONICS GmbH

Standard Accessories

FM antenna × 1
RCA video cable × 1
AC power cord × 1
Batteries (AAA, R03, UM-4) × 2
Remote control (RC-798S) × 1
Instruction manual (this document) × 1

Note

- In catalogs and on packaging, the letter at the end of the product name indicates the color. Specifications and operations are the same regardless of color.

Using Remote Control

Installing the Batteries

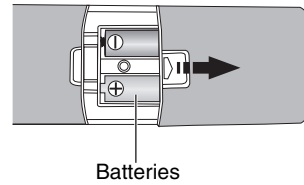

Note

- If the remote control doesn't work reliably, try replacing the batteries.
- Don't mix new and old batteries or different types of batteries.
- If you intend not to use the remote controller for a long time, remove the batteries to prevent damage from leakage or corrosion.
- Remove expired batteries as soon as possible to prevent damage from leakage or corrosion.

Aiming the Remote Control

To use the remote control, point it at the DVD receiver's remote control sensor, as shown below.

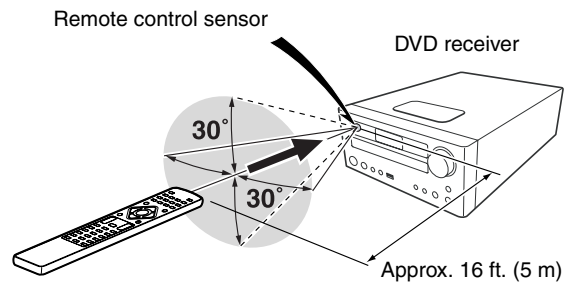

Features

Highlights

- Compact-Size Home Entertainment DVD Systems for iPod
- iPod Direct Connection via Top Panel
- Front Panel USB Interface for Flash Drives

Amplifier / DVD Player / USB Features

(North American)

- 20 W/Ch, 8 ohms, 20 kHz, 2Ch Driven (FTC)

(Others)

- 40 W/Ch, 4 ohms, 1 kHz, 1Ch Driven (IEC)
- Digital Amplifier Circuitry to Maintain Clean Audio Signals
- 1080p Video Upscaling via HDMI*3 Output
- Front-Panel Audio Input for Portable Devices
- 1 Audio Input and 1 Output
- 1 Component Video Output
- 1 Digital Output (Coaxial)
- 1 Video Output
- 1 Subwoofer Pre Out
- Tone Control (Bass/Treble)
- Super Bass Function
- Plays DVD-Video*1, Video CD, Audio CD, CD-R and CD-RW, DVD-R and DVD-RW
- MP3, WMA, JPEG, DivX*4 Formats
- CD 4 Play Modes (Normal/Memory/Random/Folder)
- Memory Playback
- 3 Repeat Modes (Track/Full/Folders (for MP3 and WMA formats))

Tuner & Other Features

- Preset Function with 20 FM Selections
- Wake-up Timer
- Aluminum Front Panel and Volume Knob

iPod Dock Features

- Recharges iPod*5
- Composite video output or component video output is possible only with iPod that support video output.



 is a trademark of DVD Format/Logo Licensing Corporation.



Manufactured under license from Dolby Laboratories. Dolby and the double-D symbol are trademarks of Dolby Laboratories.

*3 **HDMI**

“HDMI, the HDMI Logo, and High-Definition Multimedia Interface are trademarks or registered trademarks of HDMI Licensing LLC in the United States and other countries.”



“DivX®, DivX Certified® and associated logos are registered trademarks of DivX, Inc. and are used under license.”



iPod, iPod classic, iPod nano, iPod shuffle, and iPod touch are trademarks of Apple Inc., registered in the U.S. and other countries.

“Made for iPod” means that an electronic accessory has been designed to connect specifically to iPod and has been certified by the developer to meet Apple performance standards.

Apple is not responsible for the operation of this device or its compliance with safety and regulatory standards.



Manufactured under license under U.S. Patent #'s: 5,451,942; 5,956,674; 5,974,380; 5,978,762; 6,487,535 & other U.S. and worldwide patents issued & pending.

DTS and the Symbol are registered trademarks, & DTS 2.0+ Digital Out and the DTS logos are trademarks of DTS, Inc. Product includes software. © DTS, Inc. All Rights Reserved.

MPEG Layer-3 audio coding technology licensed from Fraunhofer IIS and Thomson.

This product is protected by certain intellectual property rights of Microsoft.

Use or distribution of such technology outside of this product is prohibited without a license from Microsoft. Windows Media is either a registered trademark or trademark of Microsoft Corporation in the United States and/or other countries.

It is forbidden by law to copy, broadcast, show, broadcast on cable, play in public, and rent copyrighted material without permission.

DVD videos are copy protected, and any recordings made from these discs will be distorted.

This item incorporates copy protection technology that is protected by U.S. patents and other intellectual property rights of Rovi Corporation.

Reverse engineering and disassembly are prohibited.

Contents

Introduction

Important Safety Instructions	2
Precautions.....	3
Standard Accessories	5
Using Remote Control	5
Features	6

Connections

Connecting the DVD receiver.....	8
FM Antenna Connection.....	8
Speaker Connection.....	8
Connection to a TV.....	9
Connection to Audio Components etc.....	10
Identifying the Parts.....	11
Main Unit	11
Remote Control	12
Discs.....	14
iPod	16
USB flash drive compatibility	17

Basic Operation

Basic Operation.....	18
Setting the Clock	18
Basic Operation.....	19
Listening to a Disc.....	19
Listening to an iPod.....	19
Listening to a USB Flash Drive	19
On-screen Menu.....	20
Basic Operations for iPod, Disc and USB Flash Drive	21
Skipping Playback.....	21
Searching for a part of a chapter or track.....	21
Selecting a Chapter or Track.....	21
Selecting the menu item (iPod)	21
Selecting Video Output (iPod)	21
Selecting Audio	21
Selecting Subtitles.....	22
Changing Camera Angle	22
Picture Zoom	22
Slow Motion.....	22
Repeat and Shuffle Playback	22
A-B Repeat Playback	22
Changing the Display Mode	23
Time Search (VCD/CD).....	23
Time Search (MP3/WMA)	23
Chapter Search/Time Search (DVD).....	23
Chapter Search/Time Search (DivX®).....	23
Programmed Playback (DVD/VCD/CD)	24
Programmed Playback (MP3/WMA)	24
Programmed Playback (DivX®).....	24

Settings

Settings.....	25
Introduction.....	25
GENERAL SETUP	25
AUDIO SETUP	26
VIDEO SETUP	27
PREFERENCE	28
PASSWORD SETUP	28

Listening to the FM Radio

Listening to the FM Radio	29
Preset Tuning	29
RDS (Display Setting of the FM) – excluding North American models	29
Listening to an External Source.....	30
Sleep Timer	30
Wake Up Timer.....	30

Troubleshooting

Troubleshooting	31
Specifications	33

Connecting the DVD receiver

FM Antenna Connection

Connect the supplied FM antenna to the FM ANTENNA socket on the unit.

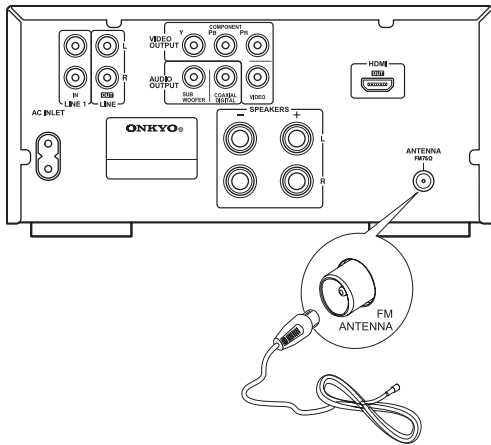

If reception is poor, connect the outdoor antenna.

Note

- Before attaching a 75 ohm coaxial cable, disconnect the supplied FM antenna.

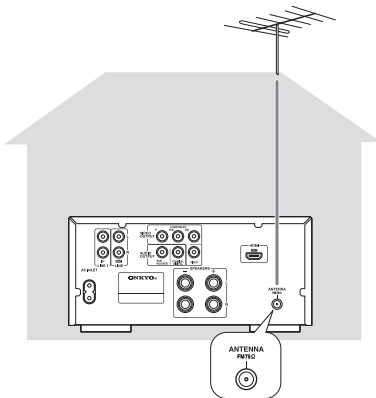

Caution

- To avoid noise, keep antennas away from the system, the connecting cord and the AC power cord.

Speaker Connection

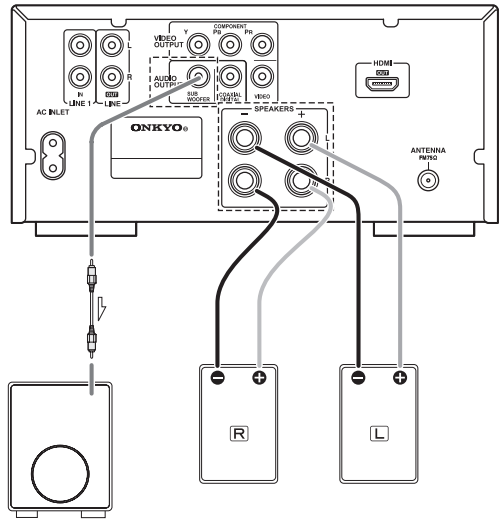

Subwoofer

Caution

- To avoid damaging the speakers with a sudden high-level signal, be sure to switch the power off before connecting the speakers.

Before connection

Check the impedance of your speakers. Connect speaker with an impedance of $4 \Omega \sim 16 \Omega$.

The black speaker terminals are “-” (negative).

Generally, the “+” side of the speaker cable is marked to make it distinguishable from the “-” side of the cable.

Connect this marked side to the “+” terminal and the unmarked side to the black “-” terminal.

How to connect

- 1** Turn the terminal cap counterclockwise to loosen it. The speaker terminal caps cannot be fully removed from the base.
- 2** Insert the wire into the terminal fully and turn the terminal cap clockwise to securely connect it:

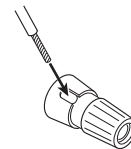

Subwoofer

Connect a subwoofer using a commercially-available RCA cable. Use a subwoofer with built-in amplifier referred to as a “powered subwoofer”.

Connection to a TV

Caution

- Turn the power off to all components before making connections.
- Read the instructions of each component you intend to use with this unit.
- Be sure to insert each plug securely. To prevent hum and noise, avoid bundling the signal interconnection cables together with the AC power cord or speaker cables.

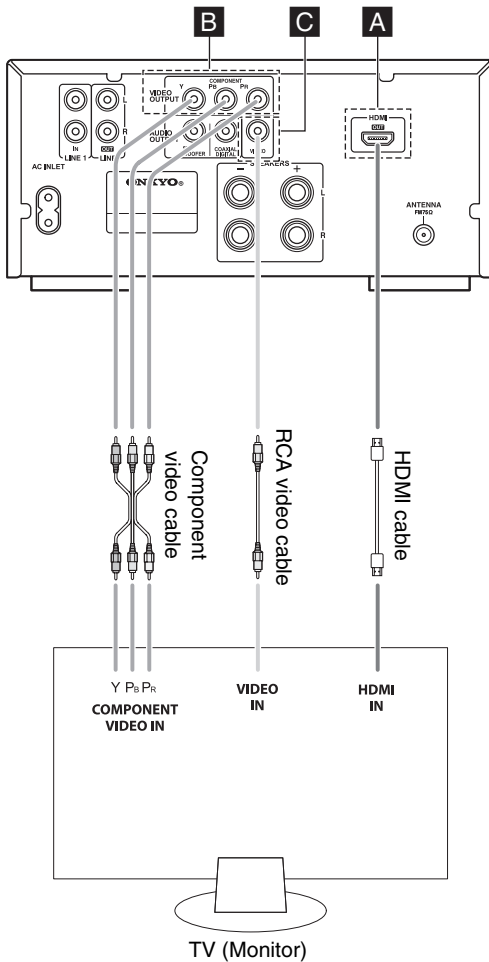

- Adjust the video aspect ratio to match that of the television.
- This unit adopts analog copy protection features. If the unit is connected to a TV through a VCR (video cassette recorder), the resulting playback may be affected. Connect the unit directly to the television.
- In all cases, use the highest quality cables for the best possible picture.
- Select proper setting in the “**VIDEO SETUP**”.

A HDMI video/audio output jack

Use an HDMI cable to connect the unit to an HDMI compatible television or monitor.

- If the television or monitor is equipped only with a DVI terminal, a suitable adapter cable or adapters should be used. Note that the television connected in this way must be HDCP compatible. Also note that this connection outputs no sound.
- Make sure that you read and understand the documentation provided with the HDMI component.

■ HDMI video output formats

- 480p (60Hz)
- 576p (50Hz)
- 720p (50Hz) or 720p (60Hz)
- 1080i (50Hz) or 1080i (60Hz)
- 1080p (50Hz) or 1080p (60Hz)

■ To output audio from the HDMI jack

If the connected HDMI component is capable of inputting HDMI audio, digital audio can be output from the HDMI jack.

- Only PCM digital audio can be output from the HDMI jack.

B Component video output jacks

Use component video cables to connect the unit to the component video inputs of a suitably equipped television or monitor to enjoy a high-quality picture. Use these terminals in preference to composite video connections.

- If the component video terminals are connected to a television with progressive scan capabilities, the output can be set to match this.
- Note that these jacks cannot be connected to high definition component jacks.

C Composite video output jack

Use a RCA (pin) video cable to connect the unit to the composite video connector of a television or monitor.

Use this connection only if no other video connection method is available.

Connection to Audio Components etc.

Caution

- Turn the power off to all components before making connections.
- Read the instructions of each component you intend to use with this unit.
- Be sure to insert each plug securely. To prevent hum and noise, avoid bundling the signal interconnection cables together with the AC power cord or speaker cables.

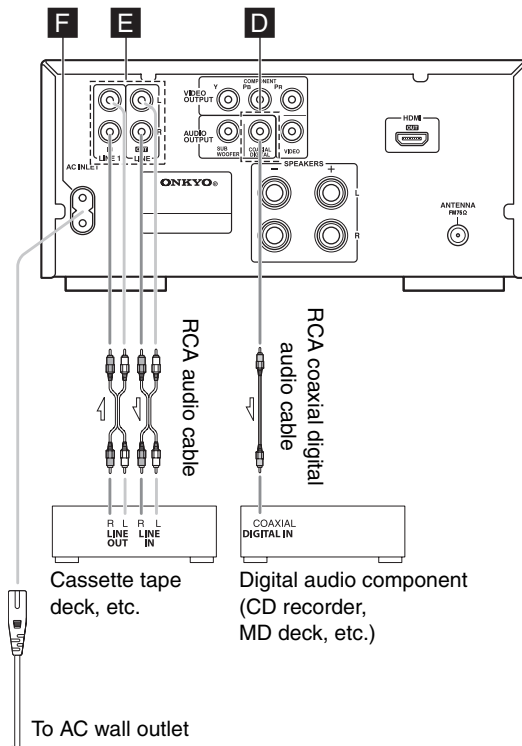

D Digital audio output jack

Digital audio from DVD-Video, CD and Video CD is output from this jack. Connect an amplifiers including a decoder, or digital audio components such as CD recorder, etc. to this jack using commercially-available coaxial digital audio cable.

- Select "ALL" or "PCM only" in the "DIGITAL AUDIO SETUP".

E LINE 1 IN/LINE OUT jacks

Analog 2-channel audio signal is input or output from these jacks. Connect a cassette tape deck etc. to these jacks using commercially-available RCA cables.

Make sure to connect:

- white plug: white jack (L: left channel)
- red plug: red jack (R: right channel)

F Power cord receptacle

After all other connections have been made, insert the supplied AC power cord into this receptacle, then connect the other end of the power cord into the wall socket.

- In order to avoid the risk of electric shock, fire, and so on, only use the supplied power cord.
- If you are not going to use the unit for some time, disconnect the power cord from the wall socket.

Identifying the Parts

Main Unit

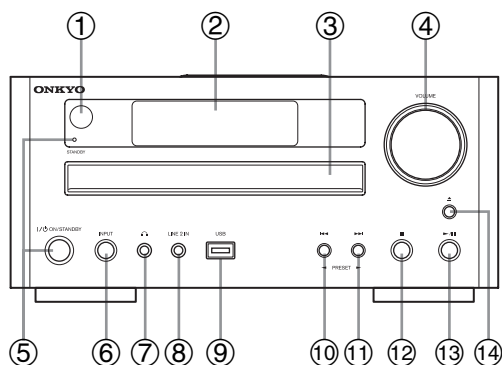

■ Top view

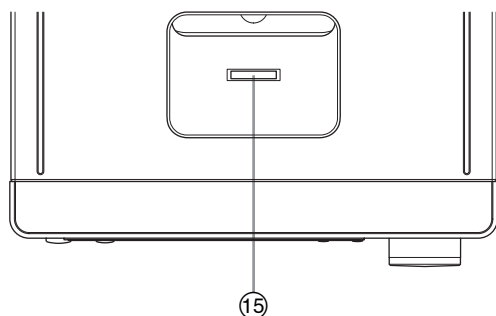

- ① **Remote control sensor**
Receives signals from the remote control. Point the remote control at this sensor when operating the remote control.
- ② **Display**
- ③ **Disc tray**
- ④ **VOLUME knob**
Turn this knob (or press ▲ VOL ▼ of the remote control) to adjust the volume level.
- ⑤ **I/O ON/STANDBY button/STANDBY indicator**
Use this button to turn the unit on and standby. The **STANDBY** indicator lights in the standby mode. It turns off when the unit is turned on.
The equipment draws nominal non-operating power from the AC outlet with its I/O ON/STANDBY in the standby mode.
- ⑥ **INPUT button**
Use this button to select an input source as follows: DVD, iPod, USB, FM, LINE1 or LINE2
- ⑦ **🎧 (headphones) jack**
For private listening, insert the headphones plug into this jack, and adjust the volume using the **VOLUME** knob.
- ⑧ **LINE 2 IN jack**
You can connect a portable audio player to this jack.
- ⑨ **USB port**
You can connect a USB flash drive to this port.
- ⑩ **⏮ button**
In DVD, iPod or USB mode, use ⏮ to skip tracks/files/songs.
◀ PRESET button
In FM mode, use ◀ **PRESET** to select a preset channel.
- ⑪ **⏭ button**
In DVD, iPod or USB mode, use ⏭ to skip tracks/files/songs.
PRESET ▶ button
In FM mode, use **PRESET ▶** to select a preset channel.
- ⑫ **■ button**
In DVD or USB mode, use this button to stop playback.
In iPod mode, use this button to pause playback.
In FM mode, use this button to select Auto mode or Mono mode.
- ⑬ **▶/|| button**
In DVD, iPod or USB mode, use this button to start or pause playback.
- ⑭ **▲ button**
Use this button to open and close the disc tray.
- ⑮ **iPod dock connector**
Connects to your iPod.

Remote Control

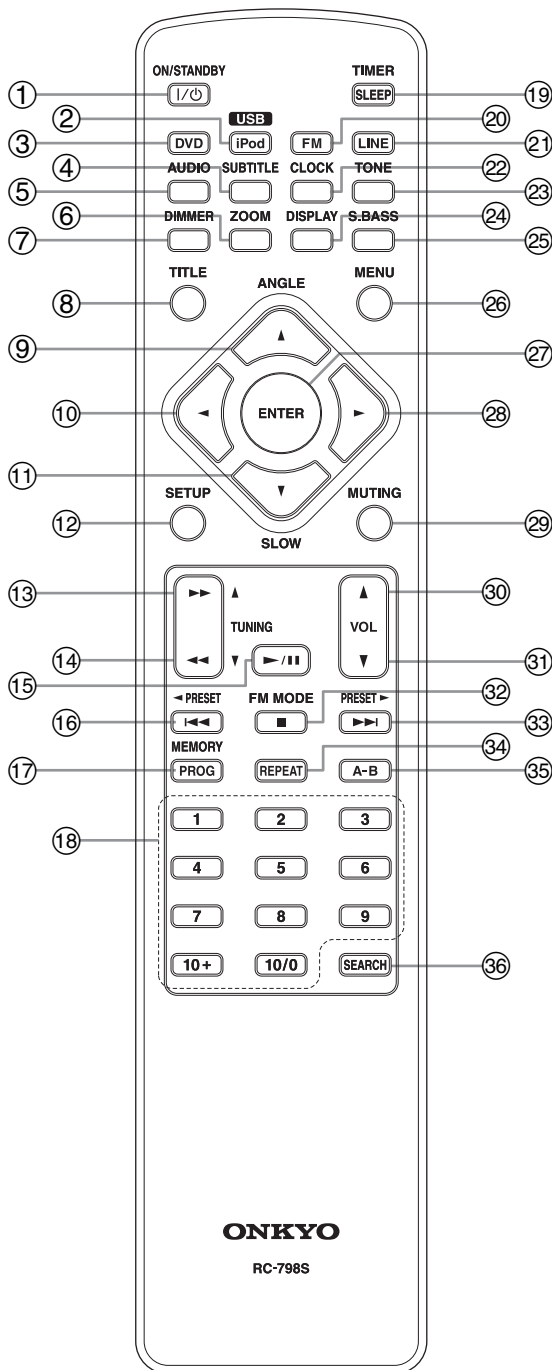

- ① **I/O ON/STANDBY button**
Use this button to turn the unit on and standby. The **STANDBY** indicator lights in the standby mode. It turns off when the unit is turned on.
- ② **iPod/USB button**
Use this button to select an “iPod” or “USB Source”.
- ③ **DVD button**
Use this button to select a “DVD Source”.
- ④ **SUBTITLE button**
Use this button to select the displayed subtitles during DVD playback.
- ⑤ **AUDIO button**
Use this button to select the audio for playback.
- ⑥ **ZOOM button**
In DVD or USB mode, use this button to enlarge the image.
- ⑦ **DIMMER button**
In standby mode, use this button to change the brightness of the front panel display.
- ⑧ **TITLE button**
During PBC playback, use this button to display a menu.
- ⑨ **▲ button**
Use ▲ for navigation of on-screen menus.
ANGLE button
Use **ANGLE** to select camera angles during DVD playback.
- ⑩ **◀ button**
Use ◀ for navigation of on-screen menus.
- ⑪ **▼ button**
Use ▼ for navigation of on-screen menus.
SLOW button
In DVD mode, use **SLOW** for slow motion video playback.
- ⑫ **SETUP button**
Use this button to enter the **SETUP** menu where you can setup the parameters of the unit.
- ⑬ **►► button**
In DVD, iPod or USB mode, use ►► to search for a part of a track/file/song.
TUNING ▲ button
In FM mode, use **TUNING ▲** to tune in a station.
- ⑭ **◀◀ button**
In DVD, iPod or USB mode, use ◀◀ to search for a part of a track/file/song.
TUNING ▼ button
In FM mode, use **TUNING ▼** to tune in a station.
- ⑮ **►/|| button**
In DVD, iPod or USB mode, use this button to start or pause playback.



- ⑩ **⏮ button**
In DVD, iPod or USB mode, use ⏮ to skip tracks/files/songs.
- ◀ **PRESET button**
In FM mode, use ▶ **PRESET** to select a preset channel.
- ⑪ **PROG button**
In DVD or USB mode, use **PROG** to programme tracks.
- MEMORY button**
In FM mode, use **MEMORY** to preset stations.
- ⑫ **Number buttons**
Use these buttons to enter track numbers, passwords, etc.
- ⑬ **SLEEP button**
When the unit is on, use **SLEEP** to set the sleep timer.
- TIMER button**
In the standby mode, use **TIMER** to set the wake up timer.
- ⑭ **FM button**
Use this button to select a “**FM Radio**”.
- ⑮ **LINE button**
Use this button to select a “**LINE1 Source**” or “**LINE2 Source**”.
- ⑯ **CLOCK button**
In standby mode, use this button to adjust clock.
- ⑰ **TONE button**
Use this button to adjust bass and treble together with ▲ **VOL ▼**.
- ⑱ **DISPLAY button**
In DVD or USB mode, use this button to display information about the currently playing disc.
In FM mode, use this button to change the information on the second line of the display. (This function only works in areas where RDS broadcasts are available.)
- ⑲ **S.BASS button**
Use this button to boost low end bass.
- ⑳ **MENU button**
In DVD mode, use this button with menu-enabled DVD discs to bring up the DVD menu.
In iPod mode, use this button to go back to previous menu of iPod.
During playback of MP3/WMA/JPEG files, use this button to switch between the folder list and the file list.
When a VCD (version 2.0) is loaded, use this button to turn the PBC function on or off.
- ㉑ **ENTER button**
Use this button to confirm menus selections.
- ㉒ **▶ button**
Use ▶ for navigation of on-screen menus.
- ㉓ **MUTING button**
Use this button to mute the sound.
- ㉔ **VOL ▲ (Volume Up) button**
Use this button to adjust the volume level.
- ㉕ **VOL ▼ (Volume Down) button**
Use this button to adjust the volume level.
- ㉖ **■ button**
In DVD or USB mode, use ■ to stop playback.
In iPod mode, use ■ to pause playback.
- FM MODE button**
In FM mode, use **FM MODE** to select auto or monaural.
- ㉗ **▶▶| button**
In DVD, iPod or USB mode, use ▶▶| to skip tracks/files/songs.
- PRESET ▶ button**
In FM mode, use **PRESET ▶** to select a preset channel.
- ㉘ **REPEAT button**
In DVD, iPod or USB mode, use this button for repeat playback.
- ㉙ **A-B button**
In DVD or USB mode, use this button to specify a section and play it repeatedly.
- ㉚ **SEARCH button**
Use this button to start time search.
In FM mode, use this button to preset stations automatically.

Discs

Type of discs that can be played on this unit

This unit can playback discs bearing any of the following logos:



This unit does not support disc types not listed.

	<p>DVD Video</p> <ul style="list-style-type: none"> • Single-sided or double-sided discs • Single layer or dual layer discs • Dolby Digital, MPEG or Linear PCM digital audio • MPEG-2 digital video • This unit can play DVD-R discs recorded in DVD video format. • This unit can play DVD-RW discs recorded in DVD video format or DVD video recording format. <p>Discs are generally divided into one or more titles. Titles may be further subdivided into chapters.</p>
	<p>Audio CD</p> <ul style="list-style-type: none"> • 12 cm or 8 cm discs • Linear PCM digital audio <p>Audio CDs are divided into tracks.</p>
	<p>Video CD</p> <ul style="list-style-type: none"> • 12 cm or 8 cm discs • MPEG-1 digital audio • MPEG-1 digital video <p>Video CDs are divided into tracks.</p>
	<p>SVCD</p> <ul style="list-style-type: none"> • 12 cm or 8 cm discs • MPEG-1 Audio Layer 2 • MPEG-2 digital video

■ Region Number of DVD Video discs

DVD players and discs are designed with region numbers that dictate the regions in which a disc can be played. If the region number on the disc you want to play does not match the region number of your DVD player, you will not be able to play the disc. In that case, an error message will appear on the screen.

The region number is printed on the rear panel of this unit.

	<p>North American</p>
	<p>European</p>
	<p>Hong Kong</p>

■ About DVD-RW

- DVD-RW discs that were recorded with copy-once only permission cannot be played.
- When playing a DVD-RW disc that was edited on a DVD recorder, the screen may momentarily black out at the edited point.
- When playing a DVD-RW disc that was edited on a DVD recorder, you may see scenes from just before the edited point.

■ About CD-R/CD-RW

CD-R/CD-RW discs recorded in Audio CD format and finalized correctly are playable. But depending on the quality of the disc and/or the condition of the recording, some CD-R/CD-RW discs may not be playable.

Caution

- If you record a disc using a personal computer, even if it is recorded in a compatible format, there are cases in which it may not play because of the settings of the application software used to create the disc. (Check with the software publisher for more detailed information.)
- Unfinalized CD-R/CD-RW/DVD-R/DVD-RW discs cannot be played.

Copy-protected discs, Dual Discs and other discs that do not conform to the CD standard may not play back correctly in this unit. If you use such discs in this unit, Onkyo Corporation and its subsidiaries cannot be responsible for any consequences or guarantee the quality of reproduction. If you experience problems with such non-standard discs, you should contact the producers of the disc.

Playable file format

This unit can play following files recorded on a CD-R, CD-RW, DVD-R, DVD-RW or USB flash drive:

- MP3 files
- WMA (Windows Media-formatted audio) files
- JPEG files
- DivX® video files (DivX® 5, DivX® 4, DivX® 3 and DivX® VOD video content)

Note





- File names should be alphanumeric characters. This unit cannot display symbols and full-size or double-byte characters (such as Japanese, Chinese, etc.) correctly. Also, be sure to use the file extension. (“mp3” for MP3 files, “.wma” for WMA files, “.avi” or “.divx” for DivX® video files, “.jpg” or “.jpeg” for JPEG files.)
- Files are played in alphabetical order.
- MP3 files must be monaural or stereo MPEG-1 Audio Layer 3 format. This unit can play MP3 files with sampling frequency 44.1 kHz or 48 kHz, bit-rate 320 kbps or less.
- This unit can play WMA files with sampling frequency 44.1 kHz, bit-rate 192 kbps or less.
- This unit cannot display the bit-rate of VBR (variable bit-rate) files correctly.

- The disc must be finalized in order to play.
- This unit is NOT compatible with multi-session discs.
- The CD-ROM must be ISO 9660 compatible.
- It may take time to display a progressive JPEG picture.
- Depending on the file size and compression rate, some JPEG pictures cannot be displayed correctly.
- Some MP3 players etc. that can connect via the USB terminal cannot be played back with this unit.

ABOUT DIVX VIDEO: DivX® is a digital video format created by DivX, Inc. This is an official DivX Certified device that plays DivX video. Visit www.divx.com for more information and software tools to convert your files into DivX video.

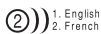
ABOUT DIVX VIDEO-ON-DEMAND: This DivX Certified® device must be registered in order to play DivX Video-on-Demand (VOD) content. To generate the registration code, locate the DivX VOD section in the device setup menu. Go to vod.divx.com with this code to complete the registration process and learn more about DivX VOD.

Example of icons used on DVD discs

	Number of audio tracks recorded on the disc
	Number of subtitles recorded on the disc
	Screen aspect ratio
	Disc recorded with multiple camera angles
	Region code

Caution

- Do not play any disc that is warped, deformed or damaged. Playing such discs may cause irreparable harm to the playing mechanisms.
- Printable discs are not recommended, as the label side might be sticky and damage the unit.
- Do not stick papers or protective sheets on the discs and do not use any protective coating spray.
- Use a soft oil-based felt-tipped pen to write the information on the label side. Never use a ball-point or hard-tipped pen, as this may cause damage to the recorded side.
- Never use a stabilizer. Using commercially available CD stabilizers with this unit will damage the mechanisms and cause them to malfunction.
- Do not use irregular shape discs (octagonal, heart shaped, business card size, etc.). Discs of this sort can damage the unit:

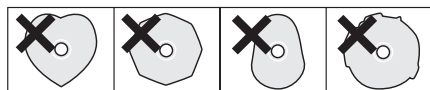

Handling precautions

- Always place the disc on the disc tray with the label side up. Compact discs can be played or recorded only on one side.
- To remove a disc from its storage case, press down on the center of the case and lift the disc out, holding it carefully by the edges.



How to remove the disc



How to hold the disc

Maintenance

- Should the disc become dirty, wipe the surface radially (from the center hole outward towards the outer edge) with a soft, dry cloth.



- Never use such chemicals as record sprays, antistatic sprays or fluid, benzine or thinner to clean the discs. Such chemicals will do irreparable damage to the disc's plastic surface.

Storage precautions

- Discs should be returned to their cases after use to avoid dust and scratches that could cause the laser pickup to "skip".
- Do not expose discs to direct sunlight or high humidity and temperature for extended periods. Long exposure to high temperatures will warp the disc.
- CD-R and CD-RW discs are more sensitive to the effects of heat and ultraviolet rays than ordinary CDs. It is important that they are not stored in a location where direct sunlight will fall on them, and away from sources of heat such as radiators or heat-generating electrical devices.

If you are in any doubt as to the care and handling of a disc, read the precautions supplied with the disc, or contact the disc manufacturer.

iPod

To play your iPod through this unit, you must first attach the Universal Dock Adapter for your model of iPod.

Compatible iPod models

Made for:

- iPod touch (1st and 2nd generation)
- iPod classic
- iPod (5th generation)
- iPod nano (1st, 2nd, 3rd, 4th and 5th generation)

Note

- Before using this unit, update your iPod with the latest software, available from the Apple Web site.

Caution

- If you use a case with your iPod, always remove it before you insert it. Otherwise, it may not connect properly and a malfunction may occur.
- Do not insert your iPod into the dock connector without the Universal Dock Adapter that came with it, as it may put unnecessary strain on the iPod or unit's dock connector, causing permanent damage.
- To prevent dock connector damage, don't twist your iPod when inserting or removing it, and be careful not to knock your iPod while it's inserted.
- Don't use your iPod with any other accessories, such as FM transmitters and microphones, because they may cause a malfunction.
- Use the Universal Dock Adapter that supplied with the iPod or a commercially available one to use the other types of iPod.
- If the Universal Dock Adapter is not supplied, or if you lose it, purchase a new Apple Universal Dock Adapter.
- When the iPod is inserted, input source is selected to "iPod" and start playback from music list automatically.
- The iPod is charged when it is inserted into the dock and the unit's power consumption is increased.
- When the iPod is inserted, the video signal is output from this unit with no video played back on the iPod LCD screen.

Handling precautions

Prepare the adapter that came with your iPod.

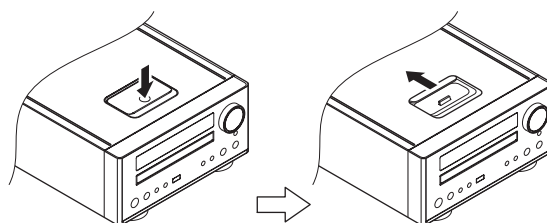

How to open the dock cover

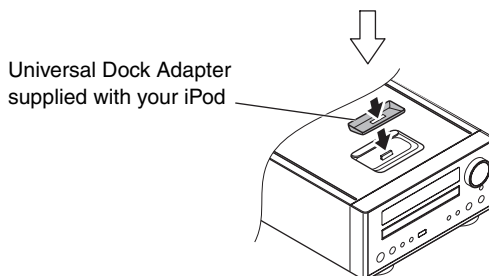

How to insert the iPod

■ Attaching the Universal Dock Adapter

Fit the front edge of the adapter into the dock, and then press in the back edge of the adapter onto the dock until a slight "click" is heard indicating the adapter is inserted correctly.

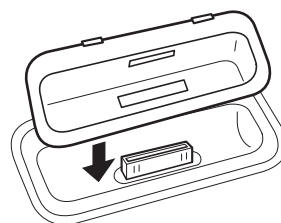

■ Removing the Universal Dock Adapter

To remove the Universal Dock Adapter from this unit, attach a small flathead screwdriver into the slot, and lift it out, as shown below.

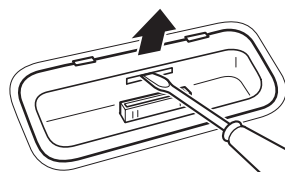

USB flash drive compatibility

- Only USB flash drive can be used.
- Some MP3 players etc. that can connect via the USB port cannot be played back with this unit.
- Hard disk drives, CD/DVD drives, and others connected via USB cannot be used.
- The unit cannot copy, move, or delete files.
- Playable format: FAT12, FAT16, FAT32
- NTFS, HFS, HFS+ cannot be used.
- Max. number of playable folders: 300
- Max. number of playable files: 650
- USB flash drive cannot be used by way of the USB hub.

Basic Operation

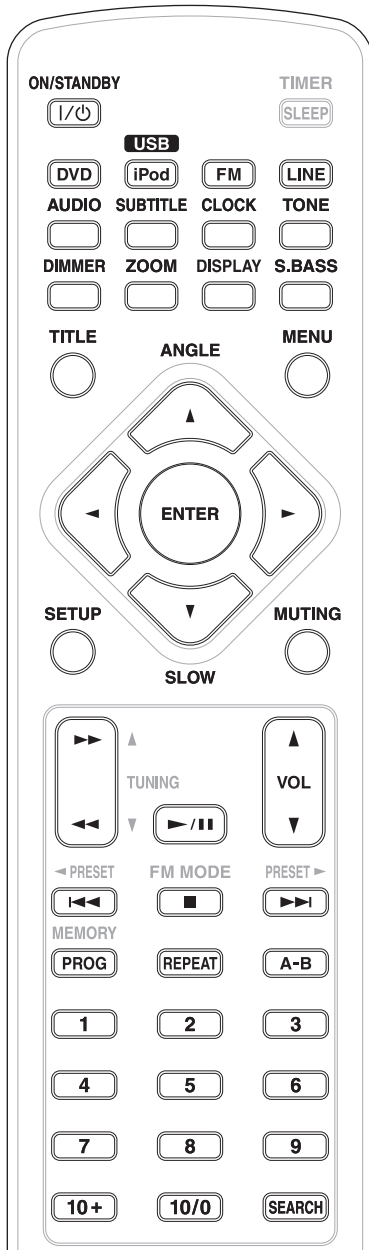

- 1 Press I/⏻ ON/STANDBY to turn the unit on.**
 - The unit turns on with the source that was last selected.
- 2 Press DVD, iPod/USB, FM, or LINE to select a source.**

The selected source is shown on the front panel's display.

Press **LINE** repeatedly to switch between LINE 1 and LINE 2.

Also, each time **INPUT** on the unit is pressed, the source changes as follows:

 - DVD Source
 - iPod
 - USB Source
 - FM Radio
 - LINE1 Source
 - LINE2 Source
- 3 Play the source, and adjust the volume using ▲ VOL ▼.**

You can rotate the **VOLUME** knob on the unit to reduce or bring up the volume continuously.

 - Press I/⏻ **ON/STANDBY** to put the unit in the standby mode when it is not being used.

Setting the Clock

- 1 If the unit is on, press I/⏻ ON/STANDBY to turn it standby.**
- 2 Press CLOCK to show the time on the display.**
 - The time appears on the display (if the time is not set after it blackout, "--:--" blinks). Press **CLOCK** again, the "hour" value starts blinking.
 - When no button is pressed for 30 seconds, the time setting mode will be cancelled.
- 3 Press ▲ VOL ▼ to set the current hour.**
- 4 Press CLOCK.**

The "minute" value starts blinking.
- 5 Press ▲ VOL ▼ to set the current minute.**
- 6 Press CLOCK.**

The clock starts.

Basic Operation

Recording a Source

You can record a source onto a CD recorder or a cassette tape recorder connected to the **COAXIAL DIGITAL AUDIO OUT** jack or the **LINE OUT** jacks.

- 1 Select a source to be recorded by pressing **DVD**, **iPod/USB**, **FM**, or **LINE**.
- 2 Start recording.
 - When the recording device is connected to the **LINE 1 IN** jack and the **LINE OUT** jack, you cannot select the **LINE 1** Source for the recording source.

Dimmer

Press **DIMMER** to dim the display.
Press **DIMMER** again to cancel the dimmer function.

Muting

To mute the sound temporarily, press **MUTING**.
Press **MUTING** again to restore the sound.

- “**MUTING**” blinks on the display while muting is engaged.
- If you change the volume when the sound is muted, it will be unmuted.

Super Bass boost

You can reinforce the bass sound to maintain rich, full bass at low volume.

Press **S.BASS** to get the effect.
Press **S.BASS** again to cancel the effect.

Adjusting the bass and treble

You can change the bass and treble sound between “-5” to “+5”.

- 1 Press **TONE** repeatedly to select Bass or Treble.
- 2 Press **▲ VOL ▼** to adjust the sound level.

Listening to a Disc

- 1 Press **DVD** to select “**DVD Source**”.
 - When no disc is loaded in the disc tray, “**NO DISC**” is displayed.
- 2 Press **▲** on the unit to open the tray.
- 3 Place the disc on the disc tray (with the printed side up).
- 4 Press **▲** on the unit again to close the tray.
 - Some discs may automatically start playback.
- 5 Press **▶/||** to start playback if playback has not started automatically.
If a menu is shown on screen (some DVD or video discs may show such a menu), see “On-screen Menu”.

Listening to an iPod

- 1 Press **iPod/USB** once or twice to select “**iPod**”.
- 2 Push your **iPod** firmly onto the unit’s dock connector.
Never insert the iPod into dock connector without the Universal Dock Adapter.
- 3 Press **▶/||** to start playback.

■ Stand-by power consumption

When charging the iPod, the power consumption may reach up to a maximum of 14 W.

Listening to a USB Flash Drive

- 1 Press **iPod/USB** once or twice to select “**USB Source**”.
- 2 Plug your **USB flash drive** into the **USB port**.
It takes a few seconds for the unit to load the USB flash drive. Some files may automatically start playback.
 - You can reverse steps 1 and 2.
- 3 Press **▶/||** to start playback if playback has not started automatically.

Note

- Do not unplug the USB flash drive before playback is stopped.

On-screen Menu

An on-screen menu is shown when a DVD, USB or Video CD with Playback Control (PBC) content is loaded.

The way in which the menu works may differ according to disc.

DVD menus

Use **▲/▼/◀/▶** to select the menu item from a DVD, and confirm the selection using the **ENTER**.

Returning to the menu screen

Press either **MENU** or **TITLE**.

- Depending on the disc, pressing **MENU** during playback may restart playback from the first chapter.

Video CDs with PBC

When a Video CD (Version 2.0) or Super Video CD with Playback Control functions (PBC) is loaded, a menu will appear on the screen.

Select an item using the number buttons to start playback.

- Press **▶▶** to advance to the next page.
Press **◀◀** to return to the previous page.
- If you press **TITLE** during playback, the menu will appear on the screen.

Turning on or off the PBC function

Press **MENU** to turn the PBC function on or off. If you press **MENU** during playback, playback will stop.

When the PBC function is off:

If you press **▶/||** in the stop mode, playback will start from the first track.

When the PBC function is on:

If you press **▶/||** in the stop mode, a menu will appear on the screen.

Select an item using the number buttons to start playback.

MP3 and Windows Media-formatted audio files

When a disc or USB is loaded, a list of directories appears on the screen and the first file will automatically start playback.

- 1** Select a directory by pressing **▲/▼** and press the **ENTER**.

File names will appear on the screen.

- 2** Select a file by pressing **▲/▼** and press the **ENTER**.

Playback will start from the selected file.

- Press **MENU** to switch between the folder list and the file list.
- If you want to return to the parent folder, display the folder list using **MENU**, select “...” using **▲/▼/◀/▶** and press **ENTER**.
- During playback, elapsed time of the current file is displayed on the front panel display.

JPEG files

- Some discs or USB flash drive may automatically start playback.

- 1** When in stop mode, use **▲/▼** to select a picture in the directory list.

After a short wait a thumbnail of the picture will appear on the right.

- Some photos may appear distorted due to the configuration or characteristics of the disc. Larger photos may take a short while to appear due to their larger data size.

- 2** Press **ENTER** or **▶/||** to viewing the picture at full-screen size.

- When viewing at full-screen size, press **◀◀/▶▶** to view a previous or next photo. You can also use **◀/▶** to rotate the image.
- When viewing at full-screen size, press **■** to display a number of thumbnails at a time on the screen.
 - You can use **▲/▼/◀/▶** to select a particular photo and then press **ENTER** to view that image at full-screen size.
 - Select “**Slide Show**” to selections played in a random order.
 - Select “**Menu**” to display “**REMOTE KEY FUNCTION**” list.
 - Select “**◀ Prev**” to display previous screen of thumbnail images.
 - Select “**Next ▶**” to display next screen of thumbnail images.
- Press **MENU** to exit thumbnail or full-screen views.

Basic Operations for iPod, Disc and USB Flash Drive

Pausing playback (Freezing the picture)

Press ►/|| to pause audio playback.
Any DVD or Video CD image is frozen.
Press ►/|| again to restart playback.

Caution

- If this unit is left in “pause” mode for an extended period of time with the screen saver set to on, the screen saver will automatically start on the television. If the screen saver is set to off, damage to your television or the player may occur.

Pausing playback (iPod)

Press ►/|| or ■. Playback stops at the current position.
• To resume playback, press ►/|| again.

Stopping playback (DVD only)

When ■ is pressed, playback is stopped, and the display shows “Press Play Key To Continue”. Pressing ►/|| to continues playback.

To cancel resume mode, press ■ (in the stop mode), ▲, INPUT or I/⏻ ON/STANDBY.

Skipping Playback

Press I◀◀/▶▶I repeatedly until the desired chapter or track is found. The selected chapter or track will be played from the beginning.

Skipping Playback (iPod only)

Press I◀◀ twice or more if you want to play the previous songs of iPod.

Searching for a part of a chapter or track

To Search quickly the disc in the forward or reverse direction, press ◀◀/▶▶ during playback.

Press ►/|| when the part you want to listen to is found. Each time ◀◀/▶▶ is pressed, the search speed changes as follows:

x2, x4, x8, x16, x32, normal speed

- The sound is muted during playback of DVD and VCD.

Searching for a part of a song (iPod)

Hold down ◀◀ or ▶▶ and release it when the part you want to listen to is found.

Selecting a Chapter or Track

Use the number buttons to select tracks or chapters for playback.

For instance, to select track number 35, press 10+, 10+, 10+ and 5.

To select a MP3 or WMA file, enter 3 digit numbers.

As an example, to select number 5, press 10/0, 10/0 and 5. (Optionally, you may press just the number 5 and then wait a few seconds.)

Selecting the menu item (iPod)

Press ▲/▼ to scroll to the menu item you want, and then press ENTER.

Going back to the previous menu (iPod)

Press MENU.

This button has the same functions as its iPod counterpart.

Selecting Video Output (iPod)

This setting is for switching the output signal of the video from iPod. Either the “Component” or “Composite” can be selected. Press SETUP to switch video output signal when “iPod” is selected as the input source.

▶ Component

If the component connection is used, select this option.

▶ Composite

If the composite connection is used, select this option.

Note

- Make sure that the video output signal is selected before you insert the iPod into the dock.
- The iPod (5th generation) only supports composite video output, so make sure you select “Composite” and connect to the television using the composite video terminal.
- The iPod nano (1st, 2nd generation) do not have a video signal output function, so cannot playback video on an external television.

Selecting Audio

Many DVD discs include audio in different languages, as well as stereo and multi-channel surround versions of the sound track. CDs and Video CDs allow the left, right or stereo channels to be selected.

Pressing AUDIO changes between the different audio tracks available, and the result is shown on screen.

- It may be necessary to change the audio on some discs using the on-screen disc menu.
- Some discs cannot have their audio changed in the way described here, as well as some discs which only have one audio stream. If you attempt to select different audio with these discs, the prohibit icon “⊘” is shown on screen.

Selecting Subtitles

Repeated presses of **SUBTITLE** cycle through available languages on a disc.

- Subtitles do not always appear immediately after the language has been selected. It may take a few seconds until the subtitles appear.
- Some captions on some discs cannot be removed or changed using this button. Some discs may have only one sub-caption language, in which case, the choice is obviously restricted to one subtitle or no subtitles.
- It may be necessary to change the subtitles on some discs using the on-screen disc menu.
- Some discs cannot have their subtitles changed in the way described here. If you attempt to select a different subtitle with these discs, the prohibit icon “⊘” is shown on screen.

Changing Camera Angle

When a scene recorded with multiple angles is played, the angle icon appears on the screen. Each time you press **ANGLE** while the angle icon is displayed, the camera angle changes.

- If you attempt to select a different angle with a disc which no other angle is recorded, the prohibit icon “⊘” will be displayed.
- **ANGLE** does not work during pause mode.

Picture Zoom

To zoom the picture, press **ZOOM** during playback. Each time **ZOOM** is pressed, the magnification level changes as follows:

■ DVD, DivX®, VCD

- ▶ 2x, 3x, 4x, 1/2, 1/3, 1/4, Normal

■ JPEG

- ▶ 100%, 125%, 150%, 200%, 150%, 125%, 100%, 75%, 50%, Normal

- You can shift the zoom point by using ◀/▶ during zoom playback.

Slow Motion

For video discs only (DVD and VCD).

To play a disc in slow motion, press **SLOW**. Each time **SLOW** is pressed, the speed changes as follows:

■ DVD

- ▶ 1/2, 1/4, 1/8, 1/16, 1/2, 1/4, 1/8, 1/16, ▶

■ VCD/DivX®

- ▶ 1/2, 1/4, 1/8, 1/16, ▶

To resume normal playback, press ▶/||.

- The sound is muted during slow-motion playback.

Repeat and Shuffle Playback

Each time **REPEAT** is pressed, the mode is changed as follows:

■ DVD

- ▶ Chapter, Title, All, Shuffle, No display

■ MP3/WMA/DivX®

- ▶ Repeat One, Repeat All, Shuffle, Off

■ VCD/CD

- ▶ Track, All, Shuffle, No display

- This feature is not available for some discs. The “prohibit” mark is shown on screen in such cases.
- If one of the following buttons is pressed, repeat mode will be cancelled:

1/⊘ **ON/STANDBY**, ▲, **INPUT**

■ iPod

- ▶ Repeat 1 (repeat one song), Repeat All (repeat all the songs in the list), Repeat Off
- When you select “One”, the Repeat One icon (🔄) appears on the display of iPod.
- When you select “All”, the Repeat icon (🔄) appears on the display of iPod.

Repeat chapter/Repeat track/Repeat one

The currently selected chapter/track/file will be played repeatedly. If another chapter/track/file is selected during repeat playback, the newly-selected chapter/track/file will repeat.

Repeat title (DVD only)

The currently selected title will be played repeatedly.

Repeat all

All the contents in the disc will be played repeatedly.

Shuffle

The whole contents of the disc will be played randomly.

A-B Repeat Playback

You can Repeat Playback of a designated section.

1 Start playback and designate the point at which the A-B repeat should start (point A) by pressing **A-B**.

“⊘A” appears on the screen.

2 When the point at which repeat playback should end (point B) is reached, press **A-B** again.

“⊘AB” appears on the screen.

The designated section will be played repeatedly.

- To fast-forward to point B after designating point A, press ▶▶.
- To cancel the A-B Repeat, press **A-B** again.

Changing the Display Mode

Each time **DISPLAY** is pressed during playback, following information appears on the screen.

■ DVD

- ▶ Title Elapsed time
- ▶ Title Remain time
- ▶ Chapter Elapsed time
- ▶ Chapter Remaining time
- ▶ Display off

■ CD/Video CD

- ▶ Single Elapsed time
- ▶ Single Remain time
- ▶ Total Elapsed time
- ▶ Total Remain time

■ DivX®

- ▶ Title Elapsed time
- ▶ Title Remain time
- ▶ Chapter Elapsed time
- ▶ Chapter Remaining time
- ▶ Display off

Time Search (VCD/CD)

You can start playback from the specified hour/minute.

1 During playback, press **SEARCH**.

To search within the entire disc

Press **SEARCH** once.

“**DT: - - : - -**” is highlighted on the screen.

To search within the current track

Press **SEARCH** twice.

“**TT: - - : - -**” is highlighted on the screen.

To select a track of the disc

Press **SEARCH** 3 times.

“**T: - - / - -**” is highlighted on the screen. Then, enter the track number using the number buttons. (For example, when you want to select track 2, press **2**.)

2 Enter your desired hour and minute using the number buttons.

For example, if the length of the current track is 3 minutes, enter a number smaller than 3 minutes. Playback starts from the selected part.

Time Search (MP3/WMA)

You can start playback from the specified hour/minute.

1 During playback, press **SEARCH**.

To search within the entire disc

Press **SEARCH** once.

“**- - -**” is highlighted on the screen.

To search within the current track

Press **SEARCH** twice.

“**- - : - -**” is highlighted on the screen.

2 Enter your desired hour and minute using the number buttons.

For example, if the length of the current file is 3 minutes, enter a number smaller than 3 minutes.

Playback starts from the selected part.

Chapter Search/Time Search (DVD)

Chapter Search

You can start playback from the beginning of the specified chapter.

1 During playback, press **SEARCH**.

To search within a chapter/title of the disc

Press **SEARCH** once.

“**T: - - / - - C: - - / - -**” is highlighted on the screen.

To search within the entire disc

Press **SEARCH** twice.

“**TITLE - - / - - TIME: - - : - -**” is highlighted on the screen.

To search within the current chapter

Press **SEARCH** 3 times.

“**CHAPTER - - / - - TIME: - - : - -**” is highlighted on the screen.

2 Enter your desired title number, chapter number or time using the number buttons.

Playback starts from the beginning of selected title number, chapter number or time.

Chapter Search/Time Search (DivX®)

Chapter Search

You can start playback from the beginning of the specified chapter.

1 During playback, press **SEARCH** once.

“**SELECT: - - -**” appears on the screen.

2 Enter your desired file number (3 digit) using the number buttons.

Playback starts from the beginning of selected file.

Time Search

You can start playback from the specified hour/minute/second.

- 1** During playback, press **SEARCH** twice. "GO TO -: -: -:" appears on the screen.
- 2** Enter your desired hour, minute and second using the number buttons. Playback starts from the selected part.

Programmed Playback (DVD/VCD/CD)

Up to 20 chapters/tracks can be programmed in the desired order.

- 1** If another source is selected, press **DVD** to select "DVD Source".
 - You can also select "DVD Source" by using **INPUT** on the unit.
- 2** Press **PROG.**

The programme list appears on the screen.

 - To cancel the programme mode, press **PROG** again, or select "EXIT" using **▲/▼/◀/▶** and press **ENTER**.
- 3** Enter your desired "TITLE", "CHAPTER" or "TRACK" using the number buttons.

For example, to enter number 5, press **5**. Repeat this step to programme more titles, chapters or tracks.

 - If you made a mistake, move the cursor on the track number and overwrite it using the number buttons.
 - To programme more than 11 chapters/tracks, press **▶▶1** to advance to the next programme page (or select "Next ▶" using **▲/▼/◀/▶** and press **ENTER**). Press **◀◀1** to return to the previous page (or select "◀ Prev" using **▲/▼/◀/▶** and press **ENTER**).
- 4** When the selection of chapter/track numbers is completed, select "START" using **▲/▼/◀/▶** and press **ENTER** to start programmed playback.
 - During programmed playback, the number buttons do not work.
 - When playback ends, the programme is cleared.
 - The programmed contents will also be cleared by using buttons as follows:
▲, **⏻** **ON/STANDBY**, **■**, **INPUT** (LINE, USB, FM)

Programmed Playback (MP3/WMA)

- 1** If another source is selected, press **DVD** or **iPod/USB** once or twice to select "DVD Source" or "USB Source".
 - You can also select "DVD Source" or "USB Source" by using **INPUT** on the unit.
- 2** Select a file using **▲/▼/◀/▶** and press **PROG.**

The file is added to the programme list.
- 3** Press **MENU** once to display the programme list.
- 4** Highlight the first file in the programme list using **▲/▼/◀/▶**.
- 5** Press **ENTER** to start programmed playback.
 - The programmed contents will be cleared by using buttons as follows:
INPUT (LINE, USB, FM), **▲** (in DVD mode), **⏻** **ON/STANDBY**

Programmed Playback (DivX®)

- 1** If another source is selected, press **DVD** or **iPod/USB** once or twice to select "DVD Source" or "USB Source".
 - You can also select "DVD Source" or "USB Source" by using **INPUT** on the unit.
- 2** Press **■** when it starts playing.
- 3** Select a file using **▲/▼/◀/▶** and press **PROG.**

The file is added to the programme list.
- 4** Press **MENU** once to display the programme list.
- 5** Highlight the first file in the programme list using **▲/▼**.
- 6** Press **ENTER** or **▶/||** to start programmed playback.
 - The programmed contents will be cleared by using buttons as follows:
INPUT (LINE, USB, FM), **▲** (in DVD mode), **⏻** **ON/STANDBY**

Settings

Introduction

This chapter describes how to use the SETUP menu. Most settings and adjustments are required to be set when you first use the system.

1 Turn on the unit and the connected television or monitor.

- The SETUP menu is available only in the “**DVD Source**” mode or the “**USB Source**” mode. If another source is selected, press **INPUT** on the unit to select the “**DVD Source**” or the “**USB Source**”.
- You can also use the remote control’s **DVD** or **iPod/USB** to select source.

2 Press **SETUP**.

The SETUP menu appears on the screen.

- To exit the SETUP menu, press **SETUP** again.
- Although it is possible to enter the SETUP menu during playback (or resume mode), not all menu functions will be available. To expand the number of available functions, press **■** twice.

3 Use **▲/▼/◀/▶** to navigate the menus.

If no cursor is visible on the screen, use **◀/▶** to select a page.

- Use **▲/▼** to highlight menu items within the selected page.
- Press **◀** to return to the upper menu.

4 Press **▶** to enter the menu item.

5 Use **▲/▼** to select the options within the menu item, and press **ENTER** to confirm the entry.

Individual menu functions are described. Repeat steps 3 through 5 as required.

6 Press **SETUP** to exit the SETUP menu.

GENERAL SETUP

TV DISPLAY

The shape of the television or monitor may not match the shape of the movie frame. To avoid distortion on older televisions, you may need to change the way in which the image is displayed. Televisions use a 4:3 aspect ratio; high-definition televisions use 16:9 aspect ratio (as do movies).

Note

- You may need to read your television’s manual in conjunction with this section in order to achieve the best results. Some discs do not allow the aspect ratio to be changed and you will therefore have to change the aspect ratio on the TV.

Make this setting while playback is stopped; you cannot do this while playing back a disc.

▶ **4:3 PANSCAN:**

This mode is used with 4:3 televisions. 4:3 images are displayed normally. When showing 16:9 programmes, the full height of the screen is displayed, and the left and right part of the image are cut off.



4:3 picture



16:9 picture

▶ **4:3 LETTERBOX:**

This mode is used with 4:3 televisions. 4:3 images are displayed normally. 16:9 images are visible at their full width, but there are blank area at the top and bottom of the screen.



4:3 picture



16:9 picture

▶ **16:9:**

Use with a 16:9 wide television.



4:3 picture



16:9 picture

- Some wide-screen discs that do not permit the Pan Scan mode playback are automatically played in Letter Box mode.
- Depending on the DVD, “**4:3 LETTERBOX**” may be selected automatically instead of “**4:3 PANSCAN**” and vice versa.
- If “**16:9**” is selected and a normal TV is connected, 16:9 content will appear distorted during playback (objects look thin).

OSD (ON SCREEN DISPLAY) LANGUAGE

Select the desired language for on screen menus of the unit from the following:

(European and North American)

- ▶ ENGLISH
- ▶ FRANÇAIS
- ▶ DEUTSCH
- ▶ ITALIANO
- ▶ ESPAÑOL

(Hong Kong)

- ▶ English
- ▶ Chinesetrad

SCREEN SAVER

- ▶ **ON:**
The screen saver starts up if nothing is played back and no operations are performed for 4 minutes.
- ▶ **OFF:**
The screen saver does not start up.

DIVX(R) CODE

- ▶ **OK:**
Display the DivX® registration code.

AUDIO SETUP

DIGITAL AUDIO SETUP

■ DIGITAL OUTPUT

- ▶ **OFF:**
Select this when you do not use the **COAXIAL DIGITAL AUDIO OUT** jack.
No signal is output from this jack.
- ▶ **ALL:**
Select this when the unit is connected to an audio component equipped with a built-in Dolby Digital decoder via the **COAXIAL DIGITAL AUDIO OUT** jack.
- ▶ **PCM only:**
Select this when the unit is connected to an audio component such as amplifier/receiver, CD recorder or MD deck via the **COAXIAL DIGITAL AUDIO OUT** jack.

DOLBY DIGITAL SETUP

■ DUAL MONO

- ▶ **STEREO:**
Left channel is output from the left speaker, and right channel is output from the right speaker.
- ▶ **L-MONO:**
Left channel is output from the front left and right speakers.
- ▶ **R-MONO:**
Right channel is output from the front left and right speakers.

3D PROCESSING

■ REVERB MODE

This setting provides following sound effects:

- ▶ **OFF**
- ▶ **CONCERT**
- ▶ **LIVING ROOM**
- ▶ **HALL**
- ▶ **BATHROOM**
- ▶ **CAVE**
- ▶ **ARENA**
- ▶ **CHURCH**

- This function is effective only when playing back a DVD disc recorded with Dolby Digital. This control has no effect on other discs.
- The overall effect of this setting depends on the disc being played, the amplifier, and the speakers used for playback.

NIGHT MODE

- ▶ **ON:**
Applies dynamic range control to Dolby Digital material, reducing the volume of loud sounds, and increasing the volume of quiet ones. This is useful for spoken word material, and nighttime listening etc.
- ▶ **OFF:**
Turns off the audio dynamic compression.

- This function is effective only when playing back a DVD disc recorded with Dolby Digital. This control has no effect on other discs.
- The overall effect of this setting depends on the disc being played, the amplifier, and the speakers used for playback.

AUDIO SYNC

This setting can cause delays in the sound signal in 10 ms increments ranging from 0 ms to 200 ms (only for digital signals recorded on a disc or stored in a USB drive; unavailable for analog signals coming from **LINE 1** or **2**).

Depending on the TV, it may take approximately 100 ms (0.1 sec.) for an image to appear after video signals are input, causing the image to appear after the sound coming from the unit is heard.

- If this happens or audio and video synchronization creates a less than optimal viewing experience, adjust the delay using ◀ (decrease) or ▶ (increase).

TV MODE

This setting allows the selection of interlaced (INTERLACE) or progressive-scan (PROGRESSIVE) video from the component video outputs.

▶ PROGRESSIVE:

For progressive scan TV: turn on the progressive scan mode.

▶ INTERLACE:

For ordinary TV: turn on the interlace mode.

- When your TV is not compatible with progressive scan, never select “**PROGRESSIVE**”. No picture will be shown on the monitor.

In case you select “**PROGRESSIVE**” by mistake, disconnect the connection of the unit and the TV, and then connect in again. And change the setting to “**INTERLACE**”.

COLOR SETTING

You can adjust some parameters of video picture.

Use ◀/▶ to select the parameter and change the value, then press **ENTER**.

■ SHARPNESS

This adjusts the sharpness of the picture shown on the monitor.

▶ HIGH

▶ MEDIUM

▶ LOW

■ BRIGHTNESS

This adjusts the brightness of the picture.

▶ -20 to +20

■ CONTRAST

This adjusts the picture contrast.

▶ -16 to +10

■ GAMMA

This adjusts the gamma value of the picture.

▶ HIGH

▶ MEDIUM

▶ LOW

▶ NONE

■ HUE

This adjusts the green/red balance of the picture (only for progressive-scan and S-Video output).

▶ -9 to +9

■ SATURATION

This adjusts the saturation level.

▶ -9 to +9

■ LUMA DELAY

This adjusts the luma delay.

▶ 0 T

▶ 1 T

HDMI SETUP

■ HDMI

▶ AUTO:

Select this to have the signal output when your TV or monitor is connected to the **HDMI OUT** jack.

▶ OFF:

Select this when you do not use the **HDMI OUT** jack.

No signal is output from the **HDMI OUT** jack.

■ RESOLUTION

You can specify the output resolution for the HDMI output.

▶ OFF

▶ 480p 60Hz

▶ 720p 60Hz

▶ 1080i 60Hz

▶ 1080p 60Hz

▶ 576p 50Hz

▶ 720p 50Hz

▶ 1080i 50Hz

▶ 1080p 50Hz

PREFERENCE

TV TYPE

- ▶ **PAL:**
Select this when the unit is connected to a PAL TV.
- ▶ **AUTO:**
Select this when the unit is connected to a Multi TV.
- ▶ **NTSC:**
Select this when the unit is connected to an NTSC TV.

AUDIO, SUBTITLE, DISC MENU

You can select a preferred language for audio, subtitle and disc menu.

- When you select a preferred language that is not recorded on the DVD, one of the recorded languages is automatically selected.
- You can override the “**AUDIO**” setting by pressing **AUDIO** on the remote control while a DVD disc is playing.
- You can override the “**SUBTITLE**” setting by pressing **SUBTITLE** on the remote control while a DVD disc is playing.
- Select “**OFF**” to turn subtitles off. Note that subtitles on some discs cannot be removed even when you select “**OFF**”.

PARENTAL

Playback of some DVD discs can be limited depending on the age of the users. The parental control system allows the playback limitation level to be set by the parent.

Note

- The lower the level, the stricter the limitation.
- If the rating of the loaded DVD disc is higher than the level you set, the system will require a password. Enter your password and press **ENTER** to start playback.

1 Select the desired parental control level from the menu, then press **ENTER**.

2 You will be prompted to enter your password. Use the number buttons to enter 2580 (or your privacy password if already established).

- No need to enter a password if “**PASSWORD MODE**” is set to “**OFF**”.

DEFAULT

All the items in the **SETUP** menu (except for the password and parental control) will be reset to the default settings.

PASSWORD SETUP

PASSWORD MODE

You can temporarily unlock discs for playback according to the level.

To change this setting, select “**ON**” or “**OFF**”, enter your password, and press **ENTER**.

▶ **ON:**

You need a password to change the level of parental control.

▶ **OFF:**

You can change the level of parental control without a password. You cannot temporarily unlock discs for playback.

PASSWORD

You can set a new password for parental control.

The default password is 2580.

1 Select “**CHANGE**” and press **ENTER**.

2 Enter 2580 (or your privacy password) using the number buttons.

3 Enter a new password.

4 Enter the same password again to confirm.

5 Press **ENTER**.

Note that you will need your password to change the level of control in the future as well as to temporarily unlock discs for playback.

If you forget your password, use 2580.

Listening to the FM Radio

1 Press **FM** to select “FM Radio”.

2 Hold down **▲ TUNING ▼** for more than 1 seconds to select the station you want to listen to (Auto selection).

When a station is tuned in, the tuning process will stop automatically.

Repeat this step until the station you want to listen to is found.

- If you want to stop the tuning process, press **▲ TUNING ▼**.

Selecting stations which cannot be tuned automatically (Manual selection)

When **▲ TUNING ▼** is pressed momentarily, the frequency changes by a fixed step.

Press **▲ TUNING ▼** repeatedly until the station you want to listen to is found.

FM MODE

Pressing **FM MODE** alternates between Auto mode and Mono mode.

■ Auto Mode

FM stereo or monaural broadcasts are received in the same mode as the signal.

■ Mono Mode

To compensate for weak FM stereo reception, select this mode. Reception will now be forced to monaural, reducing unwanted noise.

If the reception is poor

For the best reception, rotate the FM antenna until you get stations clearly.

Preset Tuning

You can store up to 20 FM stations.

Automatic Memory Presetting

1 Press **FM** to select “FM Radio”.

2 Press **SEARCH**.

Up to 20 of the received stations in your area will be stored automatically.

Manual Memory Presetting

1 Tune in a station.

2 Press **MEMORY**.

3 Select a preset channel to store the station using **◀ PRESET ▶**, and then press **MEMORY**.

How to select preset stations

1 Press **FM** to select “FM Radio”.

2 Select a preset channel using **◀ PRESET ▶**.

- You can also select a preset channel by using **◀ PRESET ▶** on the unit.

RDS (Display Setting of the FM) – excluding North American models

The Radio Data System (RDS) is a broadcasting service which allows stations to send additional information along with the regular radio programme signal.

1 Tune in an FM RDS station (see “Listening to the FM Radio”).

2 Press **DISPLAY**.

Each time **DISPLAY** is pressed, the RDS mode is changed as follows:

■ PS (Programme Service name)

Automatically displays the FM station name when PS data is received.

■ PROG TYPE (Programme Type)

Displays the programme type. If there is no PTY data, “NO PTY” will be displayed.

■ RDS CLOCK

Displays the information about times provided from the station.

If there is no time data, “NO CT” will be displayed.

RDS only works in areas where RDS broadcasts are available.

Listening to an External Source

- 1** Connect a cassette tape deck etc. to **LINE 1 IN** jack of the unit using commercially-available RCA cables.
Or Connect the audio output jack of a portable audio player to the **LINE 2 IN** jack of the unit.
 - When you connect the portable audio player to **LINE 2 IN** jack of the unit, use the stereo mini plug cable.
- 2** Press **LINE** to select “**LINE1 Source**” or “**LINE2 Source**”.
- 3** Play the source, and adjust the volume using **▲ VOL ▼** of the unit and of the audio player. You can also adjust the volume by using the **VOLUME** knob on the unit.

Sleep Timer

The power can be switched off after a specified amount of time.

Press **SLEEP** repeatedly until desired time appears on the display.

- ▶ **SLEEP 10, 20, 30, 60 or 90:**
The power will be switched off 90 (60, 30, 20, or 10) minutes later.
 - ▶ **SLEEP OFF:**
The sleep timer is off.
- If you want to check the remaining time, press **SLEEP** once. The remaining time will be displayed for 3 seconds, and then return to the normal display.

Wake Up Timer

The unit can be programmed to turn on at a specified time.

- Adjust the clock before setting the timer.

- 1** If the unit is on, press **I/⏻ ON/STANDBY** to turn the unit standby.
- 2** Press **CLOCK** to show the time on the display.
- 3** Press **TIMER**.
“**Timer Set**” appears on the display, and the “hour” value starts blinking.
 - When no button is pressed for 30 seconds, the timer setting mode will be cancelled.
- 4** Press **▲ VOL ▼** to set the start time (hour), and then press **TIMER**.
The “minutes” value starts blinking.
- 5** Press **▲ VOL ▼** to set the start time (minute), and then press **TIMER**.
The “Off” starts blinking.
- 6** Press **▲ VOL ▼** to turn On or Off the timer function, and then press **TIMER**.
Select “**On**” to turn the timer function on. The **TIMER** indicator (⏻) appears on the display. When you do not use the timer, select “**Off**”. (The **TIMER** indicator disappears from the display.)
- 7** Turn the unit on and prepare the source.
 - To play a disc, select “**DVD Source**” using **INPUT** and set a disc.
 - To play a USB flash drive, select “**USB Source**” using **INPUT** and set a USB flash drive.
 - To listen to the FM, select “**FM Radio**” using **INPUT** and tune in a station.
- 8** Press **I/⏻ ON/STANDBY** to turn the unit standby.
 - The unit will turn on at the specified time every day.
 - The unit turns on with the source that was last selected.

Do not forget to turn the unit to standby, or the timer will not work.

If the timer reaches the timer-on time, the unit is set to “**SLEEP 60**” automatically and the power will be turned standby 60 minutes later.

If you want to listen continuously, press **SLEEP** repeatedly to select “**SLEEP OFF**” before reaches the timer-off-time.

Troubleshooting

To keep the warranty valid, never try to repair the system yourself. If you encounter problems when using this unit, check the following points before requesting service.

If normal operation cannot be obtained, unplug the power cord from the outlet and plug it again. This resets the internal micro-computer which can be disturbed during electrical storms, power interruptions, etc.

If unplugging the AC power cord does not solve the problem, try the following procedure to reset the internal micro-computer.

Note that resetting the unit will delete your radio presets and custom settings.

■ Resetting the System setup

1. Turn the unit on.
2. Press **■** for 3 seconds while holding down the **▶/||**.

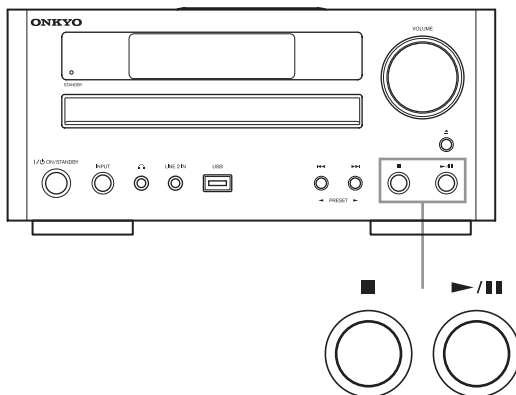

3. Release **■** and **▶/||** when “DR-645**” appears on the display.
4. Press **■**.

■ Resetting the DVD setup

To reset the custom settings on OSD to its default value, try the following procedure.

1. Turn the unit on.
2. Press **SETUP**. Setup menu appears on the display.
3. Select “**PREFERENCE**”, and then select “**DEFAULT**”.
4. Select “**RESET**”.

DR-645

■ No power

Ensure that the AC power cord of the apparatus is connected properly.

Ensure that there is power at the AC wall outlet.

Press **I/O** **ON/STANDBY** to turn the unit on.

■ No disc detected

Insert a disc.

Check if the disc is inserted upside down.

Wait until the moisture condensation at the lens has cleared.

Replace or clean the disc.

Use a finalized CD or correct format disc.

■ No picture

Check the video connection.

Turn on the TV to the correct Video-In channel.

Progressive scan is activated but the TV does not support progressive scan.

■ Black and white or distorted picture

The disc does not match the TV color system standard (PAL/NTSC).

Sometimes a slight picture distortion may appear. This is not a malfunction.

Clean the disc.

A distorted picture may appear during progressive scan setup.

■ The aspect ratio of the TV screen cannot be changed even though you have set the TV display format

The aspect ratio is fixed on the loaded DVD disc.

The aspect ratio may not be changed for some TV systems.

■ No sound or poor sound

Adjust the volume.

Disconnect the headphones.

Check that the speakers are connected correctly.

Check if the stripped speaker wires are clamped.

■ Remote control does not work

Before you press any function button, first select the correct source.

Reduce the distance between the remote control and the unit.

Insert the battery with its polarities (+/-) aligned as indicated.

Replace the battery.

Aim the remote control directly at the sensor on the front of the unit.

■ Disc does not play

Insert a readable disc and ensure that the label side faces up.

Check the disc type, color system and regional code. Check for any scratches or smudges on the disc.

Press **MENU** to exit the system setup menu.

Disable the password for parental control or change the rating level.

If condensation is suspected, unplug the AC power cord and leave DR-645 for two to three hours in the room temperature before playing any discs.

■ Poor radio reception

Increase the distance between the unit and your TV or VCR.

Fully extend the FM antenna.

Connect an outdoor FM antenna instead.

■ Unable to select Progressive Scan

Ensure the video output mode is set to [Y PB PR].

■ Audio or subtitle languages cannot be set

The disc is not recorded with sound or subtitles in multiple languages.

The audio or subtitle language setting is prohibited on the disc.

■ Cannot display some files in USB flash drive

The number of folders or files in the USB flash drive has exceeded a certain limit. This phenomenon is not a malfunction.

The formats of these files are not supported.

■ USB flash drive not supported

The USB flash drive is incompatible with the unit. Try another one.

■ Timer does not work

Set the clock correctly.

Switch on the timer.

■ Clock/timer setting erased

Power has been interrupted or the power cord has been disconnected.

Reset the clock/timer.

iPod

■ No Sound or Video

Make sure your iPod is connected properly.

If there's no video, make sure your iPod supports TV out.

Make sure your iPod is playing.

On your TV, make sure that the video input to which the unit is connected is selected.

Make sure all plugs are pushed in all the way.

Try resetting your iPod.

Video on the iPod LCD screen is not output to the monitor. Only the video content is output.

The iPod video signal is not output via HDMI.

■ Remote Control does not work

Make sure your iPod is seated properly on the dock connector. If your iPod is in a case, it may not connect properly, so always remove the case before inserting your iPod into the DR-645.

Your iPod cannot be controlled while it's displaying the Apple logo.

If you're using the remote control, be sure to point it toward DR-645 when you want to control your iPod.

Try resetting your iPod.

Changing setting will not take effect if done while pausing or video playback.

■ Others

Depending on the backlight setting on your iPod, the display may become dim during use. If the display is hard to see, change the backlight setting on your iPod.

Connecting the iPod to the dock automatically turns on the TV output.

If the iPod does not function normally even when inserted in the dock connector, check that the iPod is firmly inserted. If the iPod still does not function after checking, remove the iPod from the dock, wait a few seconds, and insert it again.

Specifications

Amplifier Section

Rated Output Power

All channels: (North American)
20 watts minimum continuous power per channel, 8 ohm loads, 2 channels driven from 20 Hz to 20 kHz, with a maximum total harmonic distortion of 10% (FTC)
(Others)
2 ch × 40 W at 4 ohms, 1 kHz (IEC)

THD (Total Harmonic Distortion)

10% (Power Rated)/0.05%

Damping Factor 30 (1 kHz, 4 Ω, 1 W)

Input Sensitivity and Impedance

600 mV/47 kΩ (LINE)

Rated RCA Output Level and Impedance

1000 mV / 1.5 kΩ (LINE OUT)

Frequency Response 20 Hz to 20 kHz, +0 / -3 dB

Tone Control Characteristics

±11.5 dB, 80 Hz (BASS)
±10 dB, 10 kHz (TREBLE)
+8.5 dB, 80 Hz (S.BASS)

Signal-to-Noise Ratio 90 dB (LINE, IHF-A)

Speaker Impedance 4 Ω - 16 Ω

FM Tuner Section

Tuning Frequency Range

(North American)
87.5 MHz to 107.9 MHz
(Others)
87.5 MHz to 108.0 MHz, RDS

DVD Player Section

Signal System NTSC/PAL

Video Output Level and Impedance

1.0 V_{p-p}/75 Ω negative sync, RCA (Composite)
1.0 V_{p-p}/75 Ω RCA (Component Y)
0.7 V_{p-p}/75 Ω RCA (Component PB/PR)

Component Video Frequency Response

5 Hz - 13 MHz

Component Video Resolution

480p 60 Hz, 720p 60 Hz, 1080i 60 Hz,
1080p 60 Hz, 576p 50 Hz, 720p 50 Hz,
1080i 50 Hz, 1080p 50 Hz

HDMI Resolution 480p 60 Hz, 720p 60 Hz, 1080i 60 Hz,
1080p 60 Hz, 576p 50 Hz, 720p 50 Hz,
1080i 50 Hz, 1080p 50 Hz

HDMI Audio Format

PCM

HDMI Version

1.2a

HDMI Connector

A Type

Frequency Response (Digital Audio)

DVD Liner Sound: 4 Hz to 44 kHz (96 kHz)
4 Hz to 22 kHz (48 kHz)
Audio CD: 4 Hz to 20 kHz (44.1 kHz)

Signal-to-Noise Ratio 80 dB

Audio Dynamic Range

80 dB

THD (Total Harmonic Distortion)

0.25% (1 kHz)

Wow and Flutter Below threshold of measurability

Audio Output/Impedance (Digital/Coaxial)

0.5 V (p-p)/50 Ω

Audio Output/Impedance (Analog)

16 V (rms)/3.3 kΩ

General

Power Supply (North American)

AC 120 V, 60 Hz

(Others)

AC 220 - 240 V, 50/60 Hz

Power Consumption 36 W

Stand-by Power Consumption

0.9 W

Dimensions (W × H × D)

215 mm × 108 mm × 348 mm
(8-7/16" × 4-1/4" × 13-11/16")

Weight

4.4 kg (9.7 lbs.)

Operation Condition Temperature/Humidity

5 °C ~ 35 °C (41 °F ~ 95 °F)/ 5% ~90%

Bus Power Supply (USB)

DC 5 V, 0.5 A

Disc Compatibility

CD-R, CD-RW, DVD-R, DVD-RW, DVD-R DL, DVD+R, DVD+RW, DVD+R DL, USB (Discs that have not been properly finalized may only be partially playable or not playable at all.)

■ HDMI

Output	OUT
Resolution	1080p/1080i

■ Video Outputs

Component	1
Composite	1

■ Audio Inputs

Analog	LINE1/LINE2
---------------	-------------

■ Audio Outputs

Digital	1 (Coaxial)
Analog	1 (LINE)
Subwoofer Pre Output	1
Speaker Outputs	SPEAKERS (L/R)
Phones	1 (3.5 ϕ)

■ Others

USB	1
iPod Connector	1

- Design and specifications are subject to change without notice.
- Weight and dimensions are approximate.

Memo

ONKYO CORPORATION

Sales & Product Planning Div. : 2-1, Nisshin-cho, Neyagawa-shi, OSAKA 572-8540, JAPAN
Tel: 072-831-8023 Fax: 072-831-8163

ONKYO U.S.A. CORPORATION

18 Park Way, Upper Saddle River, N.J. 07458, U.S.A.
Tel: 800-229-1687, 201-785-2600 Fax: 201-785-2650 <http://www.us.onkyo.com/>

ONKYO EUROPE ELECTRONICS GmbH

Liegnitzerstrasse 6, 82194 Groebenzell, GERMANY
Tel: +49-8142-4401-0 Fax: +49-8142-4401-555 <http://www.eu.onkyo.com/>

ONKYO EUROPE ELECTRONICS GmbH (UK BRANCH)

The Coach House 81A High Street, Marlow, Buckinghamshire, SL7 1AB, UK
Tel: +44-(0)1628-473-350 Fax: +44-(0)1628-401-700

ONKYO CHINA LIMITED

Unit 1 & 12, 9/F, Ever Gain Plaza Tower 1, 88, Container Port Road, Kwai Chung,
N.T., Hong Kong. Tel: 852-2429-3118 Fax: 852-2428-9039
<http://www.ch.onkyo.com/>

Y1007-1

SN 29400514

(C) Copyright 2010 ONKYO CORPORATION Japan. All rights reserved.



* 2 9 4 0 0 5 1 4 *