

Operating instructions

Combined fridge-freezer

GB

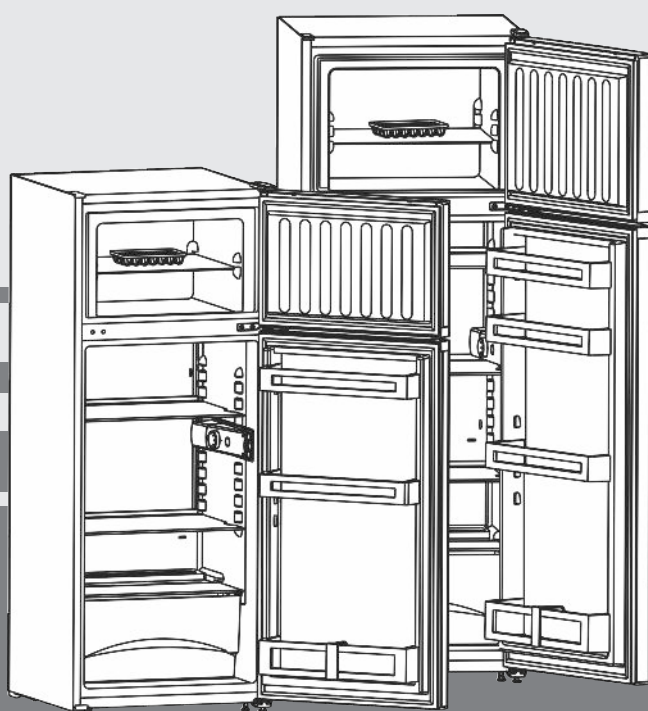

070313 **7082812 - 00**

CTP(sl)21../25../29.. ... 1

LIEBHERR

Appliance at a glance

Contents

1	Appliance at a glance	2
1.1	Overview of the appliance and equipment.....	2
1.2	Range of appliance use.....	2
1.3	Conformity.....	3
1.4	External dimensions of the appliance.....	3
1.5	Saving energy.....	3
2	General safety information	3
3	Controls and displays	4
3.1	Operating controls.....	4
4	Putting into operation	4
4.1	Transporting the appliance.....	4
4.2	Installing the appliance.....	4
4.3	Changing over the door hinges.....	5
4.4	Insertion into a row of kitchen units.....	6
4.5	Disposing of packaging.....	7
4.6	Connecting the appliance.....	7
4.7	Switching on the appliance.....	7
5	Control	7
5.1	Refrigerator compartment.....	7
5.2	Freezer compartment.....	8
6	Maintenance	8
6.1	Manual defrosting.....	8
6.2	Cleaning the appliance.....	9
6.3	Changing the interior light.....	9
6.4	Customer service.....	9
7	Malfunction	10
8	Decommissioning	10
8.1	Switching off the appliance.....	10
8.2	Taking the appliance out of service.....	10
9	Disposing of the appliance	11

The manufacturer works constantly on the further development of all the types and models. Therefore please understand that we have to reserve the right to make design, equipment and technical modifications.

To get to know all the benefits of your new appliance, please read the information contained in these instructions carefully.

The instructions apply to several models. Differences may occur. Text relating only to specific appliances is marked with an asterisk (*).

Instructions for action are marked with a ►, the results of action are marked with a ▷.

1 Appliance at a glance

1.1 Overview of the appliance and equipment

Note

- Place food inside the appliance as shown in the diagram. This allows the appliance to save energy during operation.
- Shelves, drawers and baskets are arranged for optimum energy efficiency on delivery.

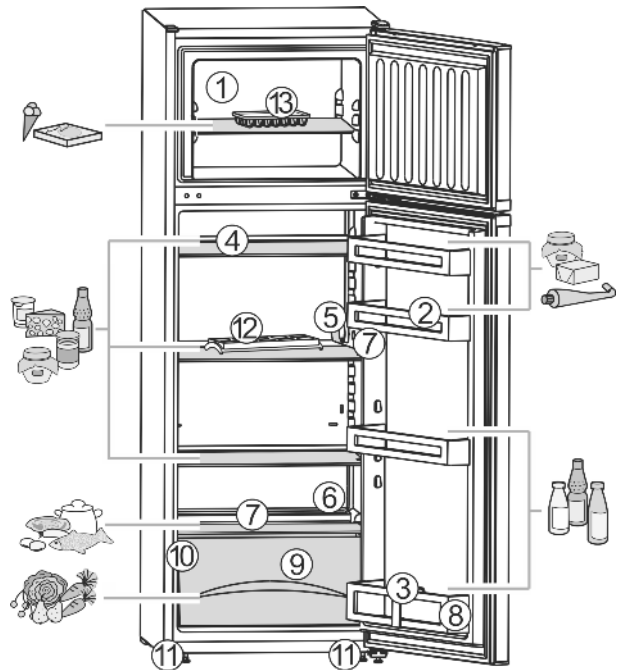

Fig. 1

- | | |
|--|---------------------------------|
| (1) Freezer compartment, glass storage shelf | (8) Door rack for large bottles |
| (2) Door rack, adjustable, number depends on model | (9) Vegetable bins |
| (3) Bottle holder | (10) Type plate |
| (4) Shelf, adjustable, number depends on model | (11) Front adjustable feet |
| (5) Thermostat housing, internal light | (12) Egg tray |
| (6) Drain opening | (13) Ice-cube tray |
| (7) Coldest area | |

1.2 Range of appliance use

The appliance is suitable solely for cooling food in a domestic environment or similar. This includes use in, for example

- in staff kitchenettes, bed and breakfast establishments,
- by guests in country homes, hotels, motels and other forms of accommodation,
- in catering and similar services in the wholesale trade

Use the appliance solely as is customary within a domestic environment. All other types of use are inadmissible. The appliance is not suitable for storing and cooling medicines, blood plasma, laboratory preparations or similar substances and products covered by the 2007/47/EC Medical Devices Directive. Misuse of the appliance can result in the stored products suffering harm or perishing. Furthermore, the appliance is not suitable for operation in potentially explosive atmospheres.

The appliance is set to operate within specific ambient temperature limits according to its

climate rating. The correct climate rating for your appliance is indicated on the type plate.

Note

► Compliance with the ambient temperatures indicated is required, otherwise the cooling performance is reduced.

Climate rating	for ambient temperatures of
SN	10 °C to 32 °C
N	16 °C to 32 °C
ST	16 °C to 38 °C
T	16 °C to 43 °C

1.3 Conformity

The refrigerant circuit is tested for leakage. The appliance complies with the relevant safety regulations and EC Directives 2006/95/EC, 2004/108/EC, 2009/125/EC and 2010/30/EU.

Note for test institutions:

Tests are to be carried out according to the applicable standards and guidelines.

Preparation and testing of the appliances must be carried out taking the **manufacturer's loading plans** and the **notes in the operating manual** into account.

1.4 External dimensions of the appliance

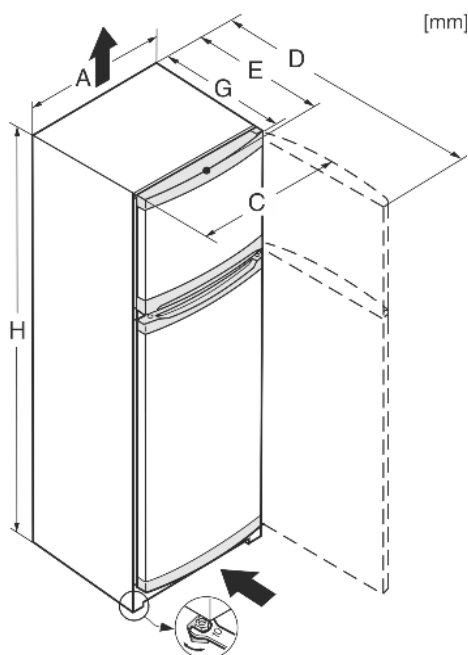

Fig. 2

	A	C	D	E	G	H
CTP(sI)2121	550	559	1128 ^x	630 ^x	616 ^x	1241
CTP(sI)2521	550	559	1128 ^x	630 ^x	616 ^x	1401
CTP(sI)2541	550	559	1128 ^x	630 ^x	616 ^x	1401
CTP(sI)2921	550	559	1128 ^x	630 ^x	616 ^x	1571

^x This dimension increases by 35 mm (see 4.2) with devices that use wall spacer brackets.

1.5 Saving energy

- Always ensure good ventilation. Do not cover ventilation openings or grille.
- Do not place appliance in areas of direct sunlight or next to a stove, heater or similar object.
- The energy consumption depends on the installation conditions, e.g. the ambient temperature (see 1.2).
- Keep the time the appliance is open to a minimum.
- The lower the temperature setting, the higher the power consumption.
- Store food logically. (see Appliance at a glance).
- Ensure that all food is well packed and covered for storage. This will prevent frost from forming.
- Remove food as needed in order that it does not warm too much.
- First cool warm food to room temperature before storing it.
- Defrost frozen food in the refrigerator.
- If there is a thick layer of frost in the appliance: defrost the appliance.

Accumulated dust increases the energy consumption:

- Once a year, dust the refrigerating unit together with the metal grille of the heat exchanger at the back of the appliance.

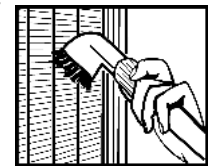

2 General safety information

Danger for the user:

- This appliance can be used by children of 8 years old and over, and also by persons with restricted physical, sensory or mental capacity or lack of experience and knowledge, if they are supervised or have been instructed on safe use of the appliance and understand the resulting risks. Children must not be allowed to play with the appliance. Cleaning and user maintenance must not be carried out by children without supervision.
- When disconnecting the appliance from the supply, always take hold of the plug. Do not pull the cable.
- In the event of a fault pull out the mains plug or deactivate the fuse.
- Do not damage the mains power cable. Do not operate the appliance with a defective mains power cable.
- Have any repairs to or intervention in the appliance, and any change of the mains power cable, carried out by the customer service only or by other specialised personnel trained for the purpose.
- Only assemble, connect and dispose of the appliance according to the instructions.
- Please keep these instructions in a safe place and pass them on to any subsequent owners.
- Special-purpose lamps (incandescent lamps, LEDs, fluorescent tubes) in the appliance serve to illuminate the appliance interior and are not suited for room illumination.

Controls and displays

Fire hazard:

- The refrigerant R 600a is environmentally friendly but flammable. Escaping refrigerant may ignite.
 - Do not damage the refrigerant circuit pipes.
 - Do not allow naked flames or ignition sources to enter the appliance.
 - Do not use any electrical appliances in the interior (e.g. steam cleaners, heaters, ice cream maker etc.).
 - If refrigerant escapes: remove any naked flames or sources of ignition from the leakage area. Ventilate the room well. Notify the after-sales service.
- Do not store explosives or sprays using combustible propellants such as butane, propane, pentane, etc. in the appliance. To identify these spray cans, look for the list of contents printed on the can, or a flame symbol. Gases possibly escaping may ignite due to electrical components.
- Keep burning candles, lamps and other items with naked flames away from the appliance so that they do not set the appliance on fire.
- Please be sure to store alcoholic drinks or other packaging containing alcohol in tightly closed containers. Any alcohol that leaks out may be ignited by electrical components.

Danger of tipping and falling:

- Do not misuse the plinth, drawers, doors etc. as a step or for support. This applies particularly to children.

Danger of food poisoning:

- Do not consume food which has been stored too long.

Danger of frostbite, numbness and pain:



- Avoid lasting skin contact with cold surfaces or refrigerated/frozen food or take protective steps, e.g. wear gloves. Do not consume ice cream, water ice or ice cubes immediately and do not consume them too cold.

Danger of injury and damage:

- Hot steam can lead to injury. Do not use electrical heating or steam cleaning equipment, open flames or defrosting sprays to defrost.
- Do not use sharp implements to remove the ice.

Please observe the specific information in the other sections:

	DANGER	identifies a situation involving direct danger which, if not obviated, may result in death or severe bodily injury.
---	---------------	---

	WARNING	identifies a dangerous situation which, if not obviated, may result in death or severe bodily injury.
	CAUTION	identifies a dangerous situation which, if not obviated, may result in minor or medium bodily injury.
	NOTICE	identifies a dangerous situation which, if not obviated, may result in damage to property.
	Note	identifies useful information and tips.

3 Controls and displays

3.1 Operating controls

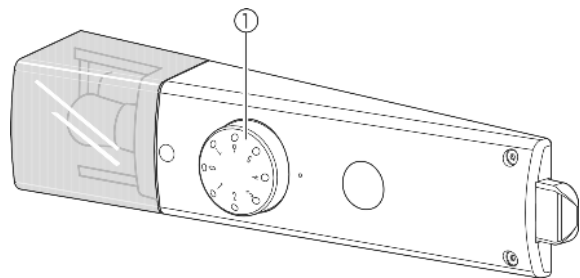

Fig. 3

(1) Temperature controller

4 Putting into operation

4.1 Transporting the appliance



CAUTION

Risk of injury and danger of damage as a result of incorrect transport!

- ▶ Transport the appliance in a packed condition.
- ▶ Transport the appliance upright.
- ▶ Do not transport the appliance without assistance.

4.2 Installing the appliance



WARNING

Fire hazard due to dampness!

If live parts or the mains lead become damp this may cause short circuits.

- ▶ The appliance is designed for use in enclosed areas. Do not operate the appliance outdoors or in areas where it is exposed to splash water or damp conditions.



WARNING

Risk of fire due to short circuit!

If the mains cable/connector of the appliance or of another appliance touch the rear of the appliance, the mains cable/connector may be damaged by the appliance vibrations, leading to a short circuit.

- ▶ Stand the appliance so that it is not touched by connectors or main cables.
- ▶ Do not plug the appliance or any others into sockets located near the rear of the appliance.



WARNING

Fire hazard due to refrigerant!

The refrigerant R 600a is environmentally friendly but flammable. Escaping refrigerant may ignite.

- ▶ Do not damage the piping of the refrigeration circuit.



WARNING

Fire hazard and danger of damage!

- ▶ Do not place appliances emitting heat e.g. microwaves, toasters etc. on the appliance!



WARNING

Blocked ventilation openings pose a risk of fire and damage!

- ▶ Always keep the ventilation openings clear. Always ensure that the appliance is properly ventilated!

NOTICE

Risk of damage due to condensate!

- ▶ Do not install the appliance directly alongside a further refrigerator/freezer.

- In the event that the appliance is damaged, contact the supplier immediately before connecting to the mains.
- The floor at the site must be flat and level.
- Do not install the appliance in a location where it is exposed to direct radiation of the sun, next to a cooker, heater and similar.
- Always stand the appliance backed directly to the wall using the enclosed wall spacers (see below).
- The appliance may be moved only when it is empty.
- Do not install the appliance without assistance.
- Standard EN 378 specifies that the room in which you install your appliance must have a volume of 1 m³ per 8 g of R 600a refrigerant used in the appliance. If the room in which the appliance is installed is too small, a flammable gas-air mixture may form in the event of a leakage in the refrigeration circuit. The quantity of refrigerant used in your appliance is indicated on the type plate on the inside of the appliance.
- ▶ Detach the connecting cable from the rear of the appliance, removing the cable holder at the same time because otherwise there will be vibratory noise!

NOTICE

The **stainless steel doors** are finished with a high quality surface coating and must not be treated with the enclosed care product,



as otherwise the surface coating will be damaged.

- ▶ Please only use a soft clean cloth to wipe the **coated door surfaces**.
- ▶ Only use a stainless steel care product on the **stainless steel side walls**, applying it evenly in the direction of polishing. Subsequent cleaning will then be easier.
- ▶ Use only a soft clean cloth to wipe **side walls and door surfaces** with a paint finish.
- ▶ Remove the protective film from the decorative trims.
- ▶ Remove all transit supports.

The spacers supplied with some appliances must be used to achieve the stated energy consumption. These will extend the depth of the appliance by approx. 35 mm. The appliance is fully functional if the spacers are not used, but does have a slightly higher energy consumption.

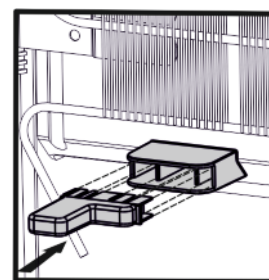

GB

- ▶ For appliances supplied with wall spacers, mount the wall spacers on the back of the appliance, left and right above the compressor.
- ▶ Dispose of packaging material (see 4.5).
- ▶ Align the appliance so that it stands firmly and on a level by applying the accompanying spanner to the adjustable-height feet (A) and using a spirit level.
- ▶ Then support the door: Extend the adjustable foot at the turn hinge (B) until it rests on the floor and then make a further 90° turn.

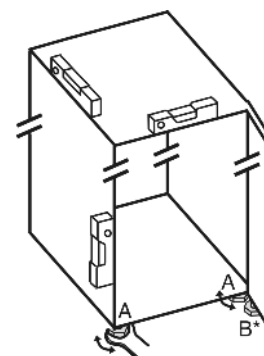

Note

- ▶ Clean the appliance (see 6.2).

If the appliance is installed in a very damp environment, condensate may form on the outside of the appliance.

- ▶ Always see to good ventilation at the installation site.

4.3 Changing over the door hinges

You can change over the door hinges if necessary.

Ensure that the following tools are to hand:

- Torx® 25
- Screwdriver
- Cordless screwdriver, if necessary
- Second person for fitting work, if needed

4.3.1 Detaching the upper door

Note

- ▶ Remove any food from the door racks before removing the door, so that no food falls out.

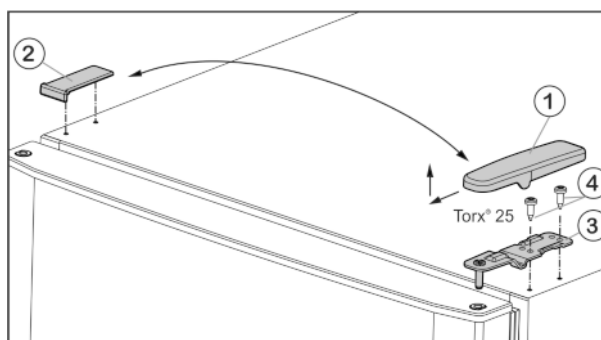

Fig. 4

- ▶ Pull off the cover Fig. 4 (1) forwards and upwards.
- ▶ Lift off the cover Fig. 4 (2).

Putting into operation



CAUTION

Risk of injury if the door tips!

- ▶ Take good hold of the door.
- ▶ Set down the door carefully.

- ▶ Unscrew the upper turn hinge *Fig. 4 (3)*(2x Torx® 25) *Fig. 4 (4)* and lift it off.
- ▶ Lift up the upper door and set it aside.

4.3.2 Detaching the lower door

- ▶ Open the lower door.



CAUTION

Risk of injury if the door tips!

- ▶ Take good hold of the door.
- ▶ Set down the door carefully.

- ▶ Unscrew the fastening screws *Fig. 5 (11)* (2 x Torx® 25) and pull the centre bearing block out of the lower door.
- ▶ Remove plastic washer *Fig. 5 (10)*.
- ▶ Lift up the door and set it aside.

4.3.3 Transferring the middle bearing elements

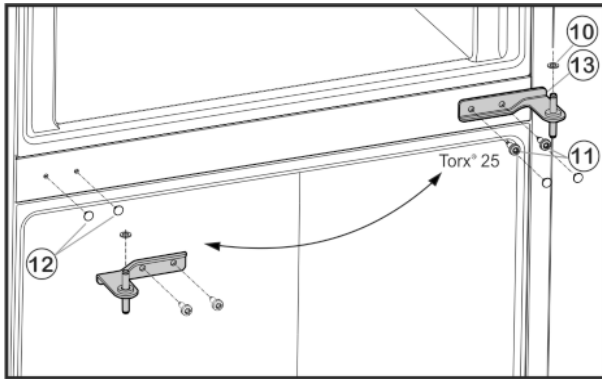

Fig. 5

- ▶ Carefully pull off the covers *Fig. 5 (12)* and fit to the opposite side.

4.3.4 Transferring the lower bearing elements

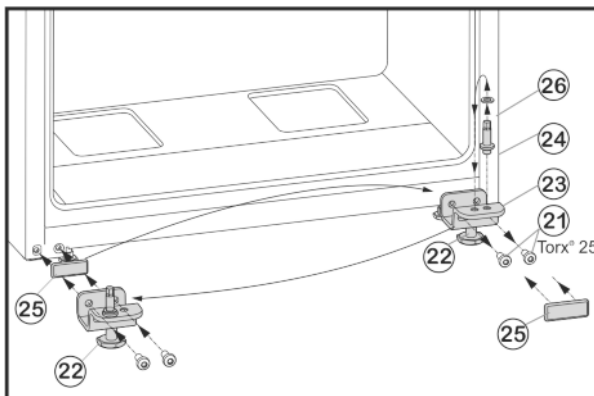

Fig. 6

- ▶ Unscrew fastening screws *Fig. 6 (21)*.
- ▶ Remove lower bearing block *Fig. 6 (23)*, complete with bearing bolt *Fig. 6 (24)*, washer *Fig. 6 (26)* and adjustable foot *Fig. 6 (22)*.
- ▶ Unscrew bearing bolt *Fig. 6 (24)* complete with washer *Fig. 6 (26)* and re-locate it into the mounting hole on the opposite side of the bearing block, tighten again.

- ▶ Carefully remove the cover plate *Fig. 6 (25)* and transfer it to the other side.
- ▶ Fasten the bearing lower block *Fig. 6 (23)* complete with bearing bolt *Fig. 6 (24)*, washer *Fig. 6 (26)* and adjustable foot *Fig. 6 (22)* to the new hinge side, with the help of a cordless screwdriver if necessary, and **tighten (with 4 Nm)** once again.

4.3.5 Fitting the lower door

- ▶ Lower the bottom door onto the bearing bolt *Fig. 6 (24)*.
- ▶ Close the door.
- ▶ Insert the centre bearing block *Fig. 5 (13)* turned through 180° into the lower door and fasten firmly (**with 4 Nm**) to the new hinge side with the fastening screws (2 x Torx® 25).
- ▶ Refit plastic washer *Fig. 5 (10)*.

4.3.6 Fitting the upper door

- ▶ Set the upper door down on the centre bearing block.
- ▶ Insert the upper turn hinge *Fig. 4 (3)* in the door on the new hinge side.
- ▶ Screw the upper turn hinge **firmly** into place (**with 4 Nm**) (2x Torx® 25) *Fig. 4 (4)*. Possibly make preliminary holes with a bradawl or use a cordless screwdriver.
- ▶ Fit the cover *Fig. 4 (1)* on the opposite side by sliding it rearwards and latching it into place.
- ▶ Press the cover *Fig. 4 (2)* on the opposite side down into place until it latches.
- ▶ Unscrew the adjustable foot *Fig. 6 (22)* on the lower bearing block *Fig. 6 (23)* until it reaches the floor.

4.4 Insertion into a row of kitchen units

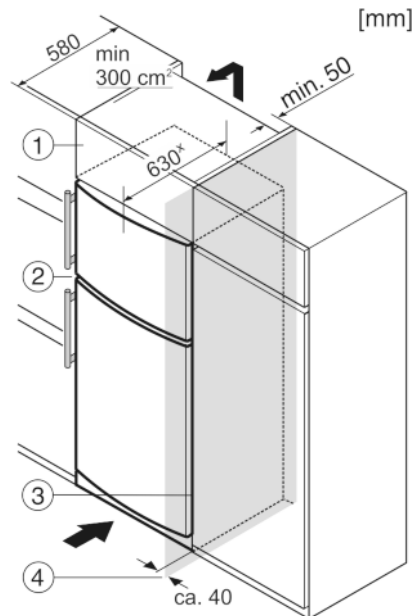

Fig. 7

- (1) Stack cabinet
- (2) Appliance
- (3) Kitchen cabinet
- (4) Wall

* For appliances supplied with wall spacers, the measurement increases by 35 mm (see 4.2).

The appliance can be inserted into a row of kitchen units. To match the appliance *Fig. 7 (2)* to the height of the row of units, a suitable stack cabinet *Fig. 7 (1)* can be fitted above the appliance.

When installing with kitchen units (max. depth 580 mm), the appliance can be positioned directly next to the kitchen cabinet *Fig. 7 (3)*. The appliance will project by 34 mm* at the sides and 50 mm* in the centre of the appliance in relation to the kitchen cabinet front.

Important for the ventilation:

- At the back of the stack cabinet there has to be a ventilation duct of at least 50 mm depth throughout the width of the stack cabinet.
- The ventilation space under the ceiling has to be at least 300 cm².
- the larger the ventilation space, the more energy-saving the appliance is in operation.

If the appliance is installed with the hinges next to a wall *Fig. 7 (4)*, the distance between appliance and wall has to be at least 40 mm. This corresponds to the projection of the handle when the door is open.

4.5 Disposing of packaging



WARNING

Danger of suffocation due to packing material and plastic film!

- ▶ Do not allow children to play with packing material.

The packaging is made of recyclable materials:

- corrugated board/cardboard
- expanded polystyrene parts
- polythene bags and sheets
- polypropylene straps
- nailed wooden frame with polyethylene panel*
- ▶ Take the packaging material to an official collecting point.



4.6 Connecting the appliance

NOTICE

Risk of damage to the electronic control system!

- ▶ Do not use stand-alone inverters (conversion of d.c. to a.c./three-phase) or energy saving plugs.



WARNING

Fire and overheating hazard!

- ▶ Do not use extension cables or multiple socket outlets.

The type of current (alternating current) and voltage at the installation site have to conform with the data on the type plate (see Appliance at a glance).

The socket must be properly earthed and fused. The tripping current for the fuse must be between 10 A and 16 A.

The socket must be easily accessible so that the appliance can be quickly disconnected from the supply in an emergency. It must be outside the area of the rear of the appliance.

- ▶ Check the electrical connection.
- ▶ Plug in the power plug.



4.7 Switching on the appliance

Put the appliance into operation about 2 hours before first loading food to be frozen.

- ▶ Turn the temperature control *Fig. 3 (1)* to the right, from the 0 setting to point 3.
- ▶ The interior light is on.

5 Control

5.1 Refrigerator compartment

The natural circulation of air in the refrigerator compartment results in zones differing in temperature. It is coldest directly

above the vegetable drawers and at the rear wall. It is warmest at the top front of the compartment and in the door.

5.1.1 Food refrigeration

- ▶ Store perishable food such as ready-to-serve dishes, meat products and sausages in the coldest zone. Place butter and preserves in the upper area and in the door (see Appliance at a glance).
- ▶ Use recyclable plastic, metal, aluminium and glass containers and cling film for wrapping.
- ▶ Always store liquids and food which is subject to odour or taste transfer in closed containers or cover them.
- ▶ Foods which give off a large amount of ethylene gas and delicate foods, such as fruit, vegetables, salad, should always be stored separately or wrapped so as not to reduce the storage life; e.g. do not store tomatoes together with kiwis or cabbage.
- ▶ Do not store food too close together to enable good air circulation.
- ▶ To safeguard bottles from tipping over: move the bottle holder.

5.1.2 Setting the temperature

The temperature can be set between 1 (warmest temperature, minimum cooling performance) and 7 (coldest temperature, maximum cooling performance).

The middle control setting is recommended, then a middle temperature of approx. 5 °C is established in the refrigerator compartment.

To ensure ideal temperatures for storing frozen foods, a setting of "4" to "7" on the temperature controller is recommended. Selecting "7" makes it possible to achieve temperatures under 0 °C in the coldest part of the fridge compartment.

An average temperature of approx. -18 °C is then established in the freezer compartment

- ▶ Turn the temperature control *Fig. 3 (1)*.

The temperature depends on the following factors:

- the door opening frequency
- the room temperature at the site where the appliance is installed
- the type, temperature and quantity of frozen food
- ▶ Adjust the temperature as needed, using the control.

5.1.3 Shelves

Relocating the shelves

The shelves have stops preventing them from being unintentionally pulled out.

- ▶ Lift the shelf and draw it out forwards.
- ▶ Insert shelf with the raised edge pointing upwards at the back.

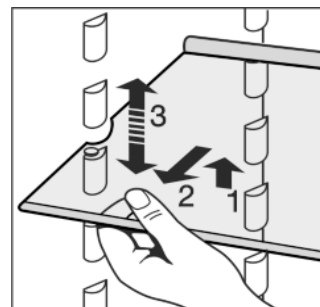

Dismantling shelves

- ▶ The shelves can be dismantled for cleaning.

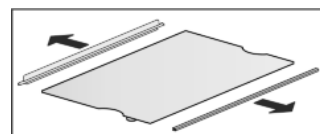

Maintenance

5.1.4 Door racks

Removing the storage rack

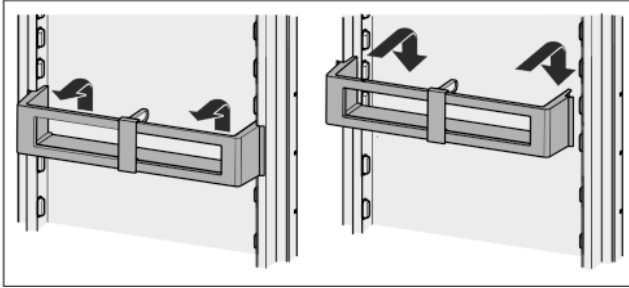

Fig. 8

Dismantling door racks

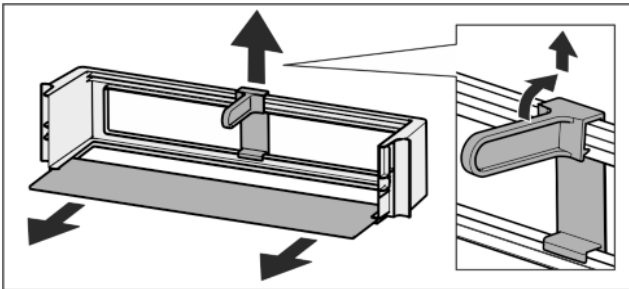

Fig. 9

- ▶ The door racks can be dismantled for cleaning.

5.2 Freezer compartment

You can store frozen food, make ice cubes and freeze fresh food in the freezer compartment.

5.2.1 Freezing food

The rating plate indicates the maximum quantity of fresh food you can freeze within 24 hours (see Appliance at a glance) under "Freezing capacity ... kg/24h".



CAUTION

Risk of injury due to broken glass!
Bottles and cans containing drinks may burst when being frozen. This applies particularly to sparkling drinks.

- ▶ Do not freeze bottles and cans containing drinks!
 - ▶ 24 h before freezing food, set the temperature to a medium to cold position.
- In order that the food is rapidly frozen through to the core, do not exceed the following quantities per pack:
- Fruit, vegetables up to 1 kg
 - Meat up to 2.5 kg
- ▶ Pack the food in portions in freezer bags, reusable plastic, metal or aluminium containers.
 - ▶ Place produce in the freezer compartment so that it touches the base or sides.
 - ▶ Spread the food over the shelf. Do not allow it to contact and thaw items that are already frozen.
 - ▶ Set the temperature back again 24 h after placing the food inside.

5.2.2 Storage life

Standard values for the storage life of various types of food in the freezer compartment:

Ice-cream	2 to 6 months
-----------	---------------

Standard values for the storage life of various types of food in the freezer compartment:

Sausage, ham	2 to 6 months
Bread, bakery products	2 to 6 months
Game, pork	6 to 10 months
Fatty fish	2 to 6 months
Lean fish	6 to 12 months
Cheese	2 to 6 months
Poultry, beef	6 to 12 months
Vegetables, fruit	6 to 12 months

The values indicated for storage life are standard ones.

5.2.3 Thawing food

- in the refrigerator compartment
- at room temperature
- in a microwave oven
- in a conventional or fan oven
- ▶ Remove only as much food as is required. Use thawed food as quickly as possible.
- ▶ Food once thawed should be re-frozen only in exceptional cases.

5.2.4 Shelves

- ▶ To remove the shelf: lift up at the front and pull out.
- ▶ To put the shelf back: simply push in as far as it will go.

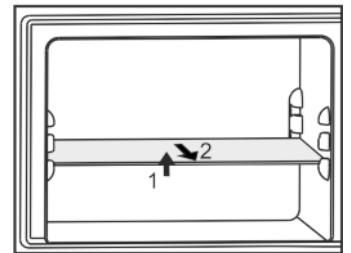

6 Maintenance

6.1 Manual defrosting

The **refrigerator compartment** is defrosted automatically. The defrost water evaporates as a result of the heat of the compressor. Drops of water on the rear wall are perfectly normal.

- ▶ Regularly clean the drain opening to allow the water to flow away (see 6.2).

A layer of frost or ice can build up in the **freezer compartment** after a long period of operation.

The layer of frost or ice builds up faster if the appliance is opened often or if the food is warm when placed inside. However, a thick layer of ice will increase the appliance's energy consumption. You should therefore defrost the appliance regularly.



CAUTION

Risk of injury and damage as a result of hot steam!

- ▶ Do not use electric heaters or steam cleaners, naked flames or defrosting sprays for defrosting.
- ▶ Do not remove ice using sharp instruments.
- ▶ Switch off the appliance.
- ▶ Pull out the power plug or switch off the fuse.

- ▶ Place a pan with hot, not boiling water on a middle shelf.



- ▷ Defrosting is speeded up.
- ▶ Leave the door of the appliance open while defrosting.
- ▶ Remove detached pieces of ice.
- ▶ If necessary, pick up defrost water several times, using a sponge or cloth.
- ▶ Clean the appliance (see 6.2) .

6.2 Cleaning the appliance



CAUTION

Risk of injury and damage as a result of hot steam!
Hot steam may damage the surfaces and cause burns.

- ▶ Do not use any steam cleaners!

NOTICE

Incorrect cleaning damages the appliance!

- ▶ Do not use cleaning agents in concentrated form.
- ▶ Do not use any scouring or abrasive sponges or steel wool.
- ▶ Please do not use any aggressive, scouring, sand-, chloride-, chemical- or acid-based cleaning agents.
- ▶ Do not use chemical solvents.
- ▶ Do not damage or remove the type plate on the inside of the appliance. It is important for the customer service.
- ▶ Do not pull off, bend or damage cables or other components.
- ▶ Do not allow any cleaning water to enter the drain channel, ventilation grille or electrical parts.
- ▶ Please use soft cleaning cloths and a universal pH-neutral cleaning agent.
- ▶ Please use cleaning and care products suitable for contact with foodstuffs in the appliance interior.

- ▶ **Empty appliance.**
- ▶ **Pull out the power plug.**



- ▶ Clean **plastic outer and inner surfaces** with lukewarm water and a little washing-up liquid.

NOTICE

The **stainless steel doors** are finished with a high quality surface coating and must not be treated with the enclosed care product,



as otherwise the surface coating will be damaged.

- ▶ Please only use a soft clean cloth to wipe the **coated door surfaces**. In the case of heavy soiling, use a little water or neutral cleaning agent. A micro-fibre cloth can be used optionally.
- ▶ When soiled, clean **stainless steel side walls** with a commercially available stainless steel cleaning agent. Then apply the enclosed stainless steel care product evenly in the direction of polishing.
- ▶ Use only a soft clean cloth to wipe **side walls and door surfaces** with a paint finish. In the case of heavy soiling, use a little water or neutral cleaning agent. A micro-fibre cloth can be used optionally.

- ▶ Clean **drain hole**: Remove deposits with a narrow instrument, e.g. a cotton bud.

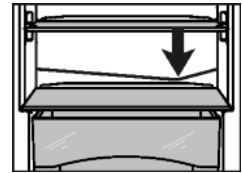

- ▶ Clean **items of equipment** by hand with lukewarm water and a little washing-up liquid.

After cleaning:

- ▶ Wipe dry the appliance and items of equipment.
- ▶ Connect the appliance and switch it on again. When the temperature is sufficiently cold:
- ▶ Put the food back inside.

6.3 Changing the interior light

In the device, an LED lamp is used as standard illumination for the interior space.

When an incandescent bulb is used:

- Use an incandescent lamp with max. 15 W and E14 socket.
- Power supply (AC) and voltage at the operating point must comply with the details on the rating plate (see Appliance at a glance).

When a LED is used:

- Use only the original LED lamp from the manufacturer. The lamp can be obtained through customer service or a specialist dealer (see 6.4) .



WARNING

Risk of injury from LED light!

The light intensity of the LED lighting corresponds to laser class 1/1M.

If the cover is removed:

- ▶ Do not look directly into the light at close quarters through optical lenses. Doing so may damage your eyes.



WARNING

Fire hazard from the LED light!

If different LED lights are used, there is a danger of overheating or fire.

- ▶ Use the manufacturer's original LED light.

If the lamp is defective, exchange it as follows:

- ▶ Switch off the appliance.
- ▶ Pull out the power plug or switch off the fuse.
- ▶ Take hold of the lamp cover.
- ▶ As shown in the diagram, press open the lamp cover on the inside at the front, and pull it off to the side.
- ▶ Replace the lamp.
- ▶ Put on the lamp cover again and snap it into place.

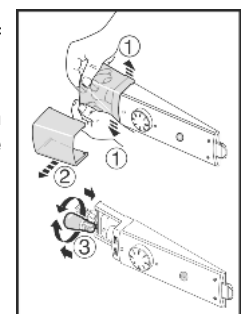

6.4 Customer service

First check whether you can correct the fault yourself by reference to the list (see Malfunction). If this is not the case, please contact the customer service whose address is given in the enclosed customer service list.

Malfuction



WARNING

Risk of injury if repair work is not carried out professionally!

- ▶ Have any repairs and action - not expressly specified - on the appliance and mains cable carried out by service personnel only. (see Maintenance)

- ▶ Read the appliance designation
Fig. 10 (1), service No. *Fig. 10 (2)* and serial No. *Fig. 10 (3)* off the type plate located inside the appliance on the left-hand side.

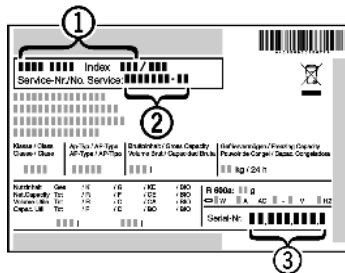

Fig. 10

- ▶ Notify the customer service, specifying the fault, appliance designation *Fig. 10 (1)*, service No. *Fig. 10 (2)* and serial No. *Fig. 10 (3)*.
- ▷ This will help us to provide you with a faster and more accurate service.
- ▶ Keep the appliance closed until the customer service arrives.
- ▷ The food will stay cool longer.
- ▶ Pull out the mains plug (not by pulling the connecting cable) or switch off the fuse.

7 Malfuction

Your appliance is designed and manufactured for a long life span and reliable operation. If a malfunction nonetheless occurs during operation, check whether it is due to a handling error. In this case you will have to be charged for the costs incurred, even during the warranty period. You may be able to rectify the following faults yourself:

Appliance does not work.

- The appliance is not switched on.
- ▶ Switch on the appliance.
- The power plug is not properly inserted in the wall socket.
- ▶ Check power plug.
- The fuse of the wall socket is not in order.
- ▶ Check fuse.

The compressor runs for a long time.

- The compressor switches to a low speed when little cold is needed. Although the running time is increased as a result, energy is saved.
- ▶ This is normal in energy-saving models.

A LED on the bottom rear of the appliance (at the compressor) flashes regularly every 15 seconds*.

- The inverter is equipped with a diagnostic LED.
- ▶ The flashing is normal.

Excessive noise.

- Speed-controlled* compressors may produce varying running noise due to different speed steps.
- ▶ The sound is normal.

A bubbling and gurgling noise.

- This noise comes from the refrigerant flowing in the refrigeration circuit.
- ▶ The sound is normal.

A quiet clicking noise.

- The noise is produced whenever the refrigeration unit (motor) automatically switches on or off.
- ▶ The sound is normal.

A hum. It is briefly a little louder when the refrigeration unit (the motor) switches on.

- The refrigeration increases automatically when fresh food has just been placed in the appliance or the door has been left open for a while.
- ▶ The sound is normal.
- The ambient temperature is too high.
- ▶ Solution: (see 1.2)

Vibratory noise.

- The appliance is not fixed to the ground. The running of the cooling unit therefore makes objects and adjacent furniture vibrate.
- ▶ Adjust appliance via the height-adjustable feet.
- ▶ Move bottles and containers apart.

The temperature is not cold enough.

- The door of the appliance is not properly closed.
- ▶ Close the door of the appliance.
- Insufficient ventilation.
- ▶ Clear ventilation grilles.
- The ambient temperature is too high.
- ▶ Solution: (see 1.2) .
- The appliance was opened too frequently or for too long.
- ▶ Wait until the appliance reaches the required temperature itself. If not, contact the customer service. (see Maintenance).
- The appliance is too close to a source of heat (stove, heater etc).
- ▶ Change the position of the appliance or the source of heat.

The interior light is not on.

- The appliance is not switched on.
- ▶ Switch on the appliance.
- The illuminant (delivery with LED illuminant) is defective.



WARNING

Risk of injury from LED light!

The light intensity of the LED lighting corresponds to laser class 1/1M.

If the cover is removed:

- ▶ Do not look directly into the light at close quarters through optical lenses. Doing so may damage your eyes.
- ▶ Replace the illuminant. (see Maintenance)

8 Decommissioning

8.1 Switching off the appliance

- ▶ Turn temperature control *Fig. 3 (1)* to 0.

8.2 Taking the appliance out of service

- ▶ Empty the appliance.
- ▶ Pull out the power plug.
- ▶ Clean the appliance (see 6.2) .

- ▶ Leave the door open to prevent odour.



9 Disposing of the appliance

The appliance contains some reusable materials and should be disposed of properly - not simply with unsorted household refuse. Appliances which are no longer needed must be disposed of in a professional and appropriate way, in accordance with the current local regulations and laws.



When disposing of the appliance, ensure that the refrigeration circuit is not damaged to prevent uncontrolled escape of the refrigerant it contains (data on type plate) and oil.

- ▶ Disable the appliance.
- ▶ Pull out the plug.
- ▶ Cut through the connecting cable.

